

TM 11-6625-2736-14

TEKTRONIX®

7623A/R7623A
STORAGE
OSCILLOSCOPE

WITH OPTIONS

SERVICE

Tektronix, Inc.
P. O. Box 500
Beaverton, Oregon 97005

INSTRUCTION MANUAL

Serial Number _____

070-168500

First Printing May 1974

Copyright 1974 by Tektronix Inc., All rights reserved
REPRODUCED BY PERMISSION OF THE COPYRIGHT OWNER, TEKTRONIX INC

TECHNICAL MANUAL
No.11-6625-2736-14
TECHNICAL MANUAL
NAVELEX 0967-LP-170-1110
TECHNICAL ORDER
TO 33A1-13-499-1

DEPARTMENTS OF THE ARMY, THE NAVY,
AND THE AIR FORCE

WASHINGTON, DC, 4 January 1978

OPERATOR'S, ORGANIZATIONAL, DIRECT SUPPORT, AND GENERAL SUPPORT MAINTENANCE MANUAL

**OSCILLOSCOPE OS-262(P)/U
(NSN 662501-007-9416)**

REPORTING OF ERRORS

You can improve this manual by recommending improvements using DA Form 2028-2 (Test) located in the back of the manual. Simply tear out the self-addressed form, fill it out as shown on the sample, fold it where shown, and drop it in the mail.

If there are no blank DA Form 2028-2 (Test) in the back of your manual, use the standard DA Form 2028 (Recommended Changes to Publications and Blank Forms) and forward to the Commander, US Army Electronics Command, AITN: DRSELMA-Q, Fort Monmouth, New Jersey 07703.

In either case a reply will be furnished direct to you.

Table of Contents

	Page
SECTION 0 Introduction.....	0-1
Scope	0-1
Indexes Publication	0-1
Forms and Records	0-1
Reporting Equipment Improvement Recommendations (EIR).....	0-1
Administrative Storage	0-1
Destruction of Army Electronics Materiel	0-1

TABLE OF CONTENTS

	PAGE
LIST OF ILLUSTRATIONS	
LIST OF TABLES	
SECTION 1	
OPERATING INFORMATION	
PRELIMINARY OPERATION	1-1
AC POWER SOURCES	1-1
AC POWER CORD	1-1
OPERATING VOLTAGE	1-1
OPERATING TEMPERATURE	1-3
RACKMOUNTING	1-3
PLUG-IN UNITS	1-4
PLUG-IN INSTALLATION AND REMOVAL	1-4
CONTROLS AND CONNECTORS	1-5
FRONT PANEL CONTROLS AND CONNECTORS	1-6
REAR PANEL CONTROLS AND CONNECTORS	1-8
GENERAL OPERATING INFORMATION	1-10
INTENSITY CONTROL	1-10
DISPLAY FOCUS	1-10
GRATICULE	1-10
LIGHT FILTER	1-11
BEAMFINDER	1-11
READOUT MODES	1-12
DISPLAY PHOTOGRAPHY	1-12
STORAGE	1-13
CARE OF STORAGE SCREEN	1-14
VERTICAL MODE	1-15
TRIGGER SOURCE	1-16
X-Y OPERATION	1-17
INTENSITY MODULATION	1-17
RASTER DISPLAY	1-18
CALIBRATOR	1-18
SIGNALS OUT	1-19
APPLICATIONS	1-20
SECTION 2	
SPECIFICATIONS	
INTRODUCTION	2-1
STANDARD ACCESSORIES	2-9

(A)

TABLE OF CONTENTS (cont)

	PAGE
SECTION 3 THEORY OF OPERATION	
LOGIC FUNDAMENTALS	3-2
SYMBOLS	3-2
LOGIC POLARITY	3-5
INPUT/OUTPUT TABLES	3-5
NON DIGITAL DEVICES	3-5
BLOCK DIAGRAM	3-5
THEORY OF OPERATION	3-9
MAIN INTERFACE <1>	3-9
LOGIC CIRCUIT <2>	3-9
Z-AXIS LOGIC	3-9
CLOCK GENERATOR	3-11
VERTICAL CHOPPED BLANKING	3-12
CHOP COUNTER	3-15
VERTICAL MODE CONTROL	3-17
VERTICAL BINARY	3-18
PLUG-IN BINARY	3-20
OUTPUT BUFFERS	3-21
TRIGGER SELECTOR<3>	3-21
TRIGGER MODE AND ADD SIGNALS	3-21
TRIGGER CHANNEL SWITCH	3-23
TRIGGER OUTPUT AMPLIFIER	3-24
VERTICAL SIGNAL BUFFER	3-25
VERTICAL INTERFACE <4>	3-25
VERTICAL CHANNEL SWITCH	3-25
AUXILIARY Y-AXIS INPUT AMPLIFIER	3-26
DELAY-LINE BUFFER	3-26
DELAY LINE	3-27
VERTICAL AMPLIFIER <4>	3-27
CENTERING AND READOUT AMPLIFIER	3-27
INPUT AMPLIFIER	3-28
BEAMFINDER NETWORK	3-28
OUTPUT AMPLIFIER	3-28
HORIZONTAL AMPLIFIER <5>	3-29
HORIZONTAL CHANNEL SWITCH	3-29
RIGHT OUTPUT AMPLIFIER	3-30
LEFT OUTPUT AMPLIFIER	3-30

(A)

TABLE OF CONTENTS (cont)

	PAGE
OUTPUT SIGNALS <6>	3-31
VERT SIG OUT	3-31
+ GATE OUT	3-31
+ SAWTOOTH OUT	3-31
CRT CIRCUIT <7>	3-31
HIGH VOLTAGE REGULATION	3-31
AUTO FOCUS DC RESTORER	3-33
AUTO FOCUS	3-34
CONTROL GRID DC RESTORER	3-34
Z-AXIS AMPLIFIER	3-34
CRT CONTROL CIRCUITS	3-35
LOW-VOLTAGE POWER SUPPLY <8>	3-35
POWER INPUT	3-35
-50-VOLT SUPPLY	3-38
-15-VOLT SUPPLY	3-40
+5-VOLT SUPPLY	3-40
+15-VOLT SUPPLY	3-40
+50-VOLT SUPPLY	3-40
+130-VOLT SUPPLY	3-40
GRATICULE LIGHT SUPPLY	3-41
CALIBRATOR <10>	3-41
READOUT SYSTEM <9>	3-43
INTRODUCTION	3-43
THREE-COMPARTMENT MAINFRAMES	3-43
DISPLAY FORMAT	3-44
DEVELOPING THE DISPLAY	3-44
TIMER	3-51
TIME-SLOT COUNTER	3-53
WORD TRIGGER	3-54
CHANNEL COUNTER	3-54
READOUT CONTROL	3-54
SINGLE-SHOT LOCKOUT	3-55
ENCODING THE DATA	3-56
COLUMN AND ROW DATA SWITCHES	3-59
DISPLAY-SKIP GENERATOR	3-60
COLUMN AND ROW DECODERS	3-60
ZEROS LOGIC AND MEMORY	3-61

(A)

TABLE OF CONTENTS (cont)

	PAGE
CHARACTER GENERATORS	3-64
DECIMAL POINT LOGIC AND CHARACTER POSITION COUNTER	3-64
FORMAT GENERATOR	3-65
Y-OUTPUT AMPLIFIER	3-67
X-OUTPUT AMPLIFIER	3-67
DISPLAY SEQUENCE	3-67
STORAGE SYSTEM <10>	3-68
LOGIC	3-68
OPERATIONAL AMPLIFIERS	3-73
SECTION 4	
MAINTENANCE	
PRELIMINARY INFORMATION	4-1
PANEL REMOVAL	4-1
POWER UNIT REMOVAL	4-2
PREVENTIVE MAINTENANCE	4-3
CLEANING	4-3
LUBRICATION	4-4
VISUAL INSPECTION	4-5
SEMICONDUCTOR CHECKS	4-5
RECALIBRATION	4-5
TROUBLESHOOTING	4-5
TROUBLESHOOTING AIDS	4-5
TROUBLESHOOTING EQUIPMENT	4-8
TROUBLESHOOTING TECHNIQUES	4-8
CORRECTIVE MAINTENANCE	4-13
OBTAINING REPLACEMENT PARTS	4-13
SOLDERING TECHNIQUES	4-13
COMPONENT REPLACEMENT	4-14
SEMICONDUCTOR REPLACEMENT	4-18
CATHODE-RAY TUBE REPLACEMENT	4-20
SWITCH REPLACEMENT	4-21
GRATICULE-BULB REPLACEMENT	4-22
POWER TRANSFORMER REPLACEMENT	4-22
HIGH VOLTAGE COMPARTMENT	4-22
FUSE REPLACEMENT	4-23
RECALIBRATION AFTER REPAIR	4-23
INSTRUMENT REPACKAGING	4-23

(A)

TABLE OF CONTENTS (cont)

		PAGE
SECTION 5	PERFORMANCE CHECK/CALIBRATION	
	PRELIMINARY INFORMATION	5-1
	CALIBRATION INTERVAL	5-1
	TEKTRONIX FIELD SERVICE	5-1
	USING THIS PROCEDURE	5-1
	TEST EQUIPMENT REQUIRED	5-1
	SPECIAL CALIBRATION FIXTURES	5-2
	CALIBRATION EQUIPMENT ALTERNATIVES	5-2
	SIGNAL CONNECTIONS	5-2
	WARM-UP AND TEMPERATURE REQUIREMENTS	5-2
	PART I-PERFORMANCE CHECK	5-4
	INTRODUCTION	5-4
	OUTLINE FOR PART I-PERFORMANCE CHECK	5-4
	PART II-CALIBRATION	5-26
	INTRODUCTION	5-26
	OUTLINE FOR PART II-CALIBRATION	5-26
SECTION 6	OPTIONS	
SECTION 7	ELECTRICAL PARTS LIST	
SECTION 8	DIAGRAMS	
SECTION 9	MECHANICAL PARTS LIST	
CHANGE INFORMATION		

(A)

LIST OF ILLUSTRATIONS

	PAGE
Frontispiece	
Figure 1-1. Location of voltage-selector jumper.	1-2
Figure 1-2. Front panel controls and connectors.	1-5
Figure 1-3. Rear panel controls and connectors.	1-9
Figure 1-4. Definition of measurement lines on the graticule.	1-11
Figure 1-5. Location of Readout Mode switch.	1-13
Figure 1-6. Location of Calibrator jumper on Storage circuit board.	1-20
Figure 3-1. Block diagram 7623A.	3-6
Figure 3-2. Logic circuit block diagram.	3-8
Figure 3-3. Z-Axis logic block diagram.	3-10
Figure 3-4. (A) Clock Generator stage of U55A.(B) Idealized waveforms from Clock Generator stage.	3-11
Figure 3-5. (A) Input and output pins for Vertical Chopped Blanking stage.(B) Idealized waveforms for Vertical Chopped Blanking stage.	3-13
Figure 3-6. (A) Logic diagram for Vertical Chopped Blanking stage.(B) Table of input/output combinations for Vertical Chopped Blanking stage.	3-16
Figure 3-7. Detailed logic diagram of Chop Counter stage.	3-17
Figure 3-8. Idealized input and output waveforms for Chop Counter stage	3-17
Figure 3-9. Logic diagram of Vertical Mode Control and Vertical Mode Buffer Amplifier stages.	3-19
Figure 3-10. Logic diagram of Vertical Binary stage.	3-19
Figure 3-11. Idealized waveforms showing relationship between input and output waveforms for Vertical Binary and Plug-In Binary stages when operating in ALT mode.	3-20
Figure 3-12. Logic diagram of Plug-In Binary and Plug-In Alternate Buffer stage.	3-21
Figure 3-13. Detailed block diagram of Trigger Selector circuit along with simplified diagram of trigger source selection circuitry.	3-22
Figure 3-14. Input levels at pin 4 of U324.	3-23
Figure 3-15. Input/output table for Trigger Channel Switch stage.	3-24
Figure 3-16. Vertical Interface detailed block diagram.	3-25
Figure 3-17. Input/output table for Vertical Channel Switch.	3-26
Figure 3-18. Vertical Amplifier detailed block diagram.	3-27
Figure 3-19. Horizontal Amplifier detailed block diagram.	3-29
Figure 3-20. CRT circuit detailed block diagram.	3-32
Figure 3-21. Low-Voltage Power Supply detailed block diagram.	3-36
Figure 3-22. Schematic illustrating voltage drop between power supply output and load due to resistance of interconnecting wire.	3-39
Figure 3-23. Calibrator detailed block diagram.	3-41
Figure 3-24. Location of readout words on the crt identifying the originating plug-in unit and channel (one complete frame shown).	3-44

(A)

LIST OF ILLUSTRATIONS (Cont.)

	PAGE
Figure 3-25. Character Selection Matrix for 7623A Readout System.	3-46
Figure 3-26. Typical readout display where only channel 2 of the Right Vertical and Horizontal units is displayed.	3-47
Figure 3-27. Detailed block diagram of the Readout System.	3-48
Figure 3-28. Output waveforms of Timer stage.	3-50
Figure 3-29. Detail of output at pins 12, 13, 14, and 16 of U2126.	3-51
Figure 3-30. Timer stage operation when Display-Skip condition occurs.	3-52
Figure 3-31. Time relationship of the time-slot (TS) pulses produced by U2159.	3-53
Figure 3-32. Typical encoding scheme for voltage-sensing amplifier plug-in unit. Coding shown for deflection factor of 100 microvolts.	3-57
Figure 3-33. Idealized current waveforms of: (A) Row analog data, (B) Column analog data.	3-58
Figure 3-34. Block representation of memory sequence in U2232.	3-61
Figure 3-35. Typical output waveforms for Zeros Logic and Memory stage operation (at pin 7 of U2232).	3-62
Figure 3-36. Readout word relating 10 possible character locations to the decimal point instructions that can be encoded, and the resultant crt display.	3-65
Figure 3-37. Flow chart for character generation by the Readout System.	3-66
Figure 3-38. Storage circuit simplified block diagram.	3-68
Figure 3-39. Time relationship of Storage logic pulses.	3-69
Figure 3-40. BISTABLE mode Storage waveforms.	3-70
Figure 3-41. VAR PERSIST mode Storage waveforms.	3-71
Figure 3-42. FAST BISTABLE mode Storage waveforms.	3-72
Figure 3-43. FAST VAR PERSIST mode Storage waveforms.	3-74
Figure 4-1. Power Unit removal.	4-2
Figure 4-2. Location of circuit boards in the 7623A.	4-6
Figure 4-3. Location of circuit boards in the R7623A.	4-7
Figure 4-4. Circuit isolation troubleshooting chart.	4-10
Figure 4-5. Location of screws holding Low Voltage sub-chassis.	4-17
Figure 4-6. Location of screws holding Signals Out rear panel.	4-18
Figure 5-1. Typical crt display when checking X-Y phase shift.	5-15
Figure 5-2. Location of Calibrator AC/DC jumper.	5-17
Figure 5-3. Location of High-Voltage Test Point.	5-30
Figure 5-4. Location of adjustments in High-Voltage cover.	5-32
Figure 5-5. Typical crt display when checking X-Y phase shift.	5-43
Figure 5-6. Location of Calibrator AC/DC jumper.	5-46

(A)

LIST OF ILLUSTRATIONS

Section 8 figures are located near their associated diagrams on the foldout pages.

- Figure 8-1. Semiconductor lead configurations.
- Figure 8-2. A1-Main Interface Board.
- Figure 8-3. A2-Logic Board.
- Figure 8-4. A3-Trigger Selector Board.
- Figure 8-5. A4-Vertical Interface Board.
- Figure 8-6. A5-Vertical Amplifier Board (front).
- Figure 8-7. A5-Vertical Amplifier Board (rear).
- Figure 8-8. A6-Horizontal Amplifier Board.
- Figure 8-9. A7-Output Signals Board.
- Figure 8-10. A8-Z-Axis Board.
- Figure 8-11. A9-Anode Board.
- Figure 8-12. A10-High-Voltage Board.
- Figure 8-13. A11-Low-Voltage Rectifier Board.
- Figure 8-14. A12-Low-Voltage Regulator Board.
- Figure 8-15. A13-Readout Board.
- Figure 8-16. A14-Storage Board.
- Figure 8-17. Adjustment locations-Low-Voltage Regulator board.
- Figure 8-18. Adjustment locations-Z-Axis board.
- Figure 8-19. Adjustment locations-High-Voltage board.
- Figure 8-20. Adjustment locations-Vertical Amplifier board.
- Figure 8-21. Adjustment locations-Horizontal Amplifier board.
- Figure 8-22. Adjustment locations-Signals Out board.
- Figure 8-23. Adjustment locations-Readout board.
- Figure 8-24. Adjustment locations-Storage board.

(A)

LIST OF TABLES

	PAGE
TABLE 1-1. Power Cord Color-Coding	1-1
TABLE 1-2. Regulating Range and Fuse Data	1-3
TABLE 2-1. ELECTRICAL	2-1
TABLE 2-2. ENVIRONMENTAL	2-8
TABLE 2-3. PHYSICAL	2-8
TABLE 2-4. 7623A SYSTEM SPECIFICATIONS	2-10
TABLE 3-1. Basic Logic Reference	3-2
TABLE 3-2. Standard Readout Format	3-45
TABLE 3-3. Channel Address Code	3-55
TABLE 4-1. Power Supply Tolerances	4-9
TABLE 4-2. Fuse Rating	4-23
TABLE 5-1. Test Equipment	5-3
TABLE 5-2. Power Supply Tolerances	5-30
TABLE 5-3. High-Frequency Compensation Adjustments	5-38

(A)

(A)

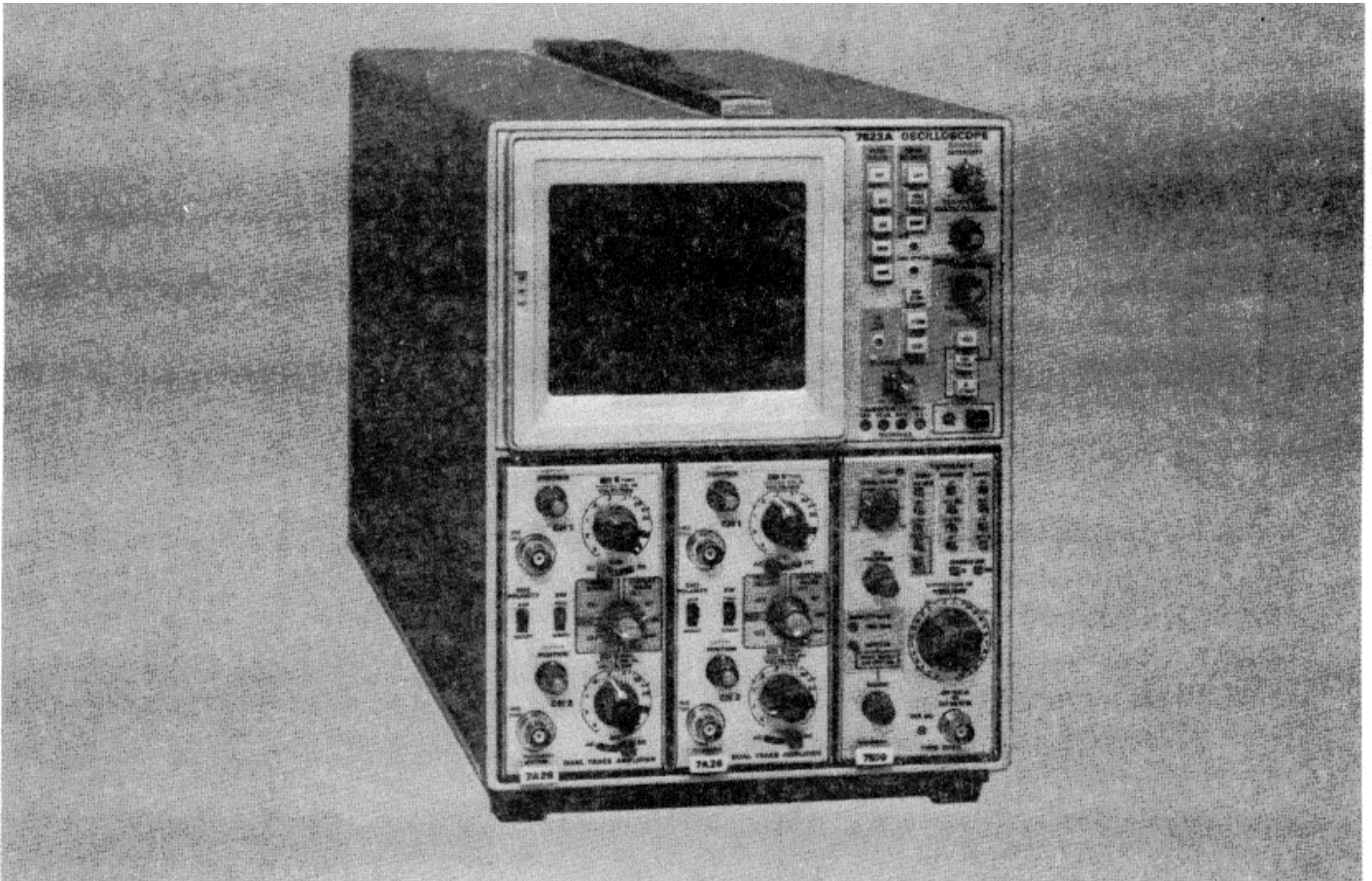

The Tektronix 7623A/R7623A Storage Oscilloscope is a solid-state instrument designed for fast writing rate storage applications. The 7623A operates in three display modes-NON STORE, STORE, and SAVE, and has four storage modes- BISTABLE, VAR PERSIST, FAST BISTABLE, and FAST VAR PERSIST. This instrument has three plug-in compartments that accept any 7-series plug-in units to form a highly flexible measurement system.

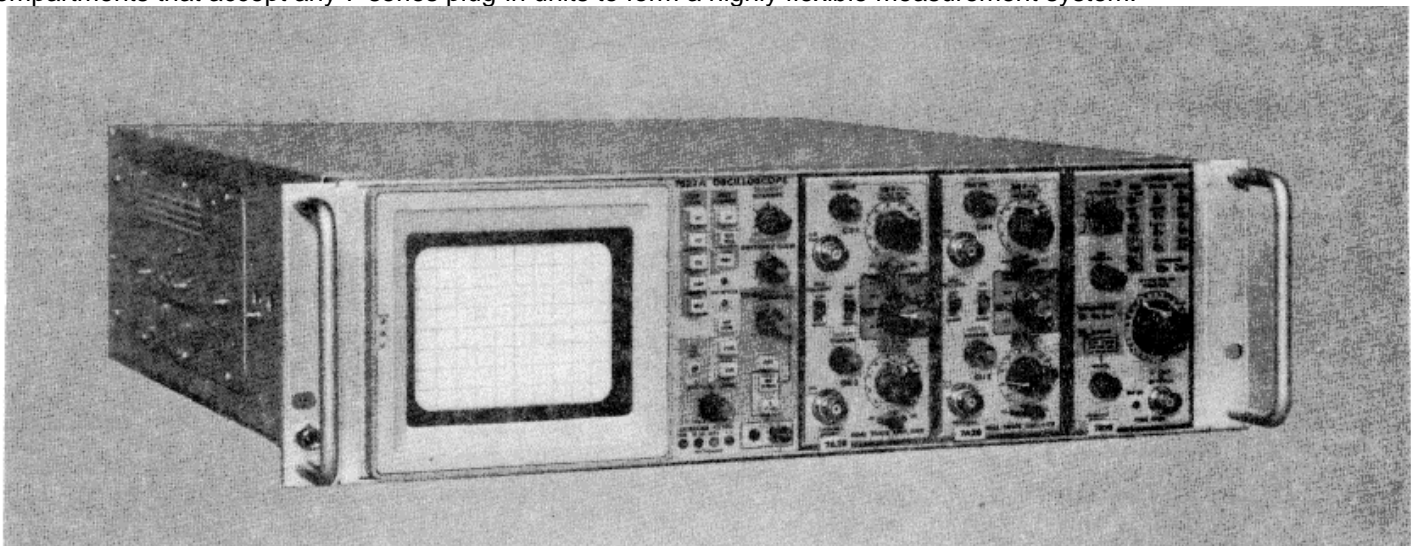

(A)

SECTION 0 INTRODUCTION

0-1. Scope

This manual contains instructions for the operation and organizational, direct support, and general support maintenance of Oscilloscope OS-262(P)/U. Throughout this manual Oscilloscope OS-262(P)/U is referred to as 7623A/R7623A Storage Oscilloscope.

0-2. Indexes of Publications

a. DA Pam 310-4. Refer to the latest issue of DA Pam 310-4 to determine whether there are new editions, changes, or additional publications pertaining to the equipment.

b. DA Pam 310-7. Refer to DA Pam 310-7 to determine whether there are modification work orders (MWO's) pertaining to the equipment.

0-3. Forms and Records

a. Reports of Maintenance and Unsatisfactory equipment. Maintenance forms, records, and reports which are to be used by maintenance personnel at all maintenance levels are listed in and prescribed by TM 38-750 (Army). Air Force personnel will use AFM 66-1 for maintenance reporting and TO-00-35D54 for unsatisfactory equipment reporting. Navy personnel will report maintenance performed utilizing the Maintenance Data Collection Subsystem (MDCS) IAW OP- NAVINST 4790.2, Vol 3 and unsatisfactory material/ conditions (UR submission) IAW OPNAVINST 4790.2, Vol 2, chapter 17.

b. Report of Packaging and Handling Deficiencies Fill out and forward DD Form 6 (Packaging Improvement Report) as prescribed in AR 700-58/NAVSUPINST

4030.29/AFR 71-13/MCO P4030.29A, and DSAR 4145.8.

c. Discrepancy in Shipment Report (DISREP) (SF 361). Fill out and forward Discrepancy in Shipment Report (DISREP) (SF 361) as prescribed in AR 55-38/NAVSUPINST 4610.33A/AFR 75-18/MCO P4610.19B and DSAR 4500.15.

0-4. Reporting Equipment Improvement Recommendations (EIR)

a. Army. EIR's will be prepared using DA Form 2407, Maintenance Request. Instructions for preparing EIR's are provided in TM 38-750, The Army Maintenance Management System EIR's should be mailed direct to Commander, US Army Electronics Command, ATTN: DRSELMA-Q, Fort Monmouth, New Jersey 07703 A reply will be furnished direct to you.

b. Navy. Navy personnel are encouraged to submit EIR's through their local Beneficial Suggestion Program.

c. Air Force. Air Force personnel are encouraged to submit EIR's in accordance with AFM 900-4.

0-5. Administrative Storage

Administrative storage of equipment issued to and used by Army activities shall be in accordance with TM 740-90-1.

0-6. Destruction of Army Electronics Materiel

Destruction of Army electronics materiel to prevent enemy use shall be in accordance with TM 750-244 2.

OPERATING INFORMATION**PRELIMINARY OPERATION**

To effectively use the 7623A/R7623A Storage Oscilloscope, the operation and capabilities of the instrument must be known. This section provides preliminary operating information, describes operation of controls and connectors, and provides an operating checkout procedure.

AC POWER SOURCES

This instrument is intended to be operated from a single-phase, earth-referenced power source having one current-carrying conductor (the Neutral Conductor) near earth potential. Operation from power sources where both current-carrying conductors are live with respect to earth (such as phase-to-phase on a three-wire system) is not recommended since only the Line Conductor has over-current (fuse) protection within the instrument.

AC POWER CORD

This instrument has a three-wire power cord with a three-terminal polarized plug for connection to the power source and safety-earth. The safety-earth terminal of the plug is directly connected to the instrument frame. For electric-shock protection, insert this plug only in a mating outlet with a safety-earth contact or otherwise connect the frame to a safety earth system. The color-coding of the cord conductors is in accordance with recognized standards as shown in Table 1-1.

TABLE 1-1.
Power Cord Conductor Identification

Conductor	Color	Alternate Color
Ungrounded (Line)	Brown	Black
Grounded (Neutral)	Blue	White
Grounding (Earthing)	Green-Yellow	Green-Yellow

OPERATING VOLTAGE

The 7623A/R7623A can be operated from either a 110-volt or a 220-volt nominal line-voltage source. In addition, three operating ranges can be selected within each nominal line voltage source. Use the following procedure to obtain correct instrument operation from the line voltage available:

1. Disconnect the instrument from the power source.
2. Remove the six screws securing the power unit (nine screws in the R7623A, see Figure 1-1)
3. Slide the power unit out of the rear of the chassis.

REV.C, FEB 1977

Operating Information-7623A/R7623A Service

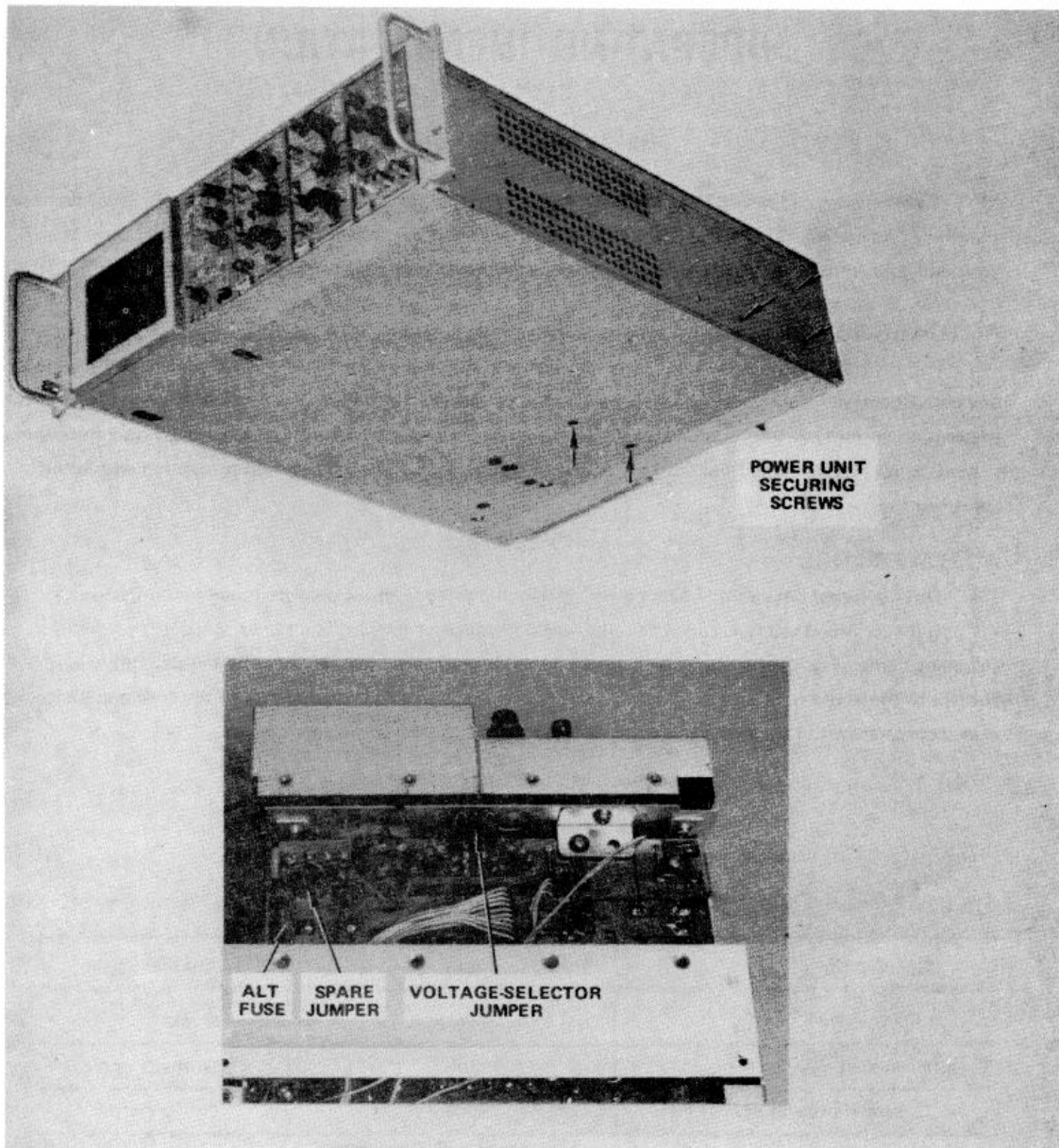

Figure 1-1. Location of voltage-selector jumper.

4. To convert from 110-volts to 220-volts nominal line voltage, or vice versa, remove the voltage-selector jumper and replace it with the spare jumper stored on the pins adjacent to the voltage selector area (see Figure 1-1). The jumpers are color coded to indicate the nominal voltage for which they are intended, brown for 110-volt nominal operation and red for 220-volt nominal operation. Change the fuse to provide protection for the selected nominal line voltage. Use the fuse located in the Alt Fuse holder on the Rectifier board (see Figure 1-1 for fuse location and Table 1-2 for fuse type). Also, change the line-cord plug to match the power-source receptacle or use a suitable adapter

(A)

Operating Information-7623A/R7623A Service

5. To convert the instrument from one regulating range to another, remove the voltage selector jumper and re-install it on the set of pins corresponding to the desired regulating range. The proper regulating range will center about the average line voltage to which the instrument is to be connected (see Table 1-2).

*TABLE 1-2.
Regulating Range and Fuse Data*

Pins Selected	Regulating Range	
	110-volts (nominal)	220-volts (nominal)
LOW	90 to 110 volts	180 to 220 volts
MED	99 to 121 volts	198 to 242 volts
HI	108 to 132 volts	218 to 262 volts
Line Fuse	3.2 A slow-blow	1.6 A slow-blow

OPERATING TEMPERATURE

The 7623A can be operated where the ambient air temperature is between 0°C and +50°C. This instrument can be stored in ambient temperatures between -55°C and +75°C. After storage at temperatures beyond the operating limits, allow the chassis temperature to come within the operating limits before power is applied.

The 7623A is cooled by air drawn in through the top, side, and bottom panels and exhausted through the rear panel. Components that require most cooling are mounted externally on a heat radiator. Adequate clearance must be provided on all sides to allow heat to be dissipated from the instrument. Do not block or restrict the air flow through the holes in the cabinet or the heat radiator. Maintain the clearance provided by the feet on the bottom and allow about two inches clearance on the top, sides, and rear (more if possible).

The R7623A is cooled by air drawn in through the air filter on the rear panel and exhausted through ports on the right side of the instrument. Adequate clearance must be provided at these locations. Allow at least one and one-half inches clearance behind the air filter and at least one inch on the right side.

A thermal cutout interrupts power to the instrument if the internal temperature exceeds a safe operating level. Power is automatically restored when the temperature returns to a safe level. Operation in confined areas or close to a heat source may cause the thermal cutout to open.

RACKMOUNTING

Instructions and dimensional drawings for rackmounting the R7623A are given in the Operators manual

(A)

PLUG-IN UNITS

The 7623A will accept up to three 7-series plug-in units. This plug-in feature permits a variety of display combinations and also allows selection of bandwidth, sensitivity, display mode, etc. to meet many measurement requirements. In addition, it allows expansion of the oscilloscope system to meet future measurement requirements. The overall capabilities of the resultant system are in large part determined by the characteristics of the plug-in selected. For complete information on plug-ins available for use with this instrument, see the current Tektronix, Inc., catalog.

PLUG-IN INSTALLATION AND REMOVAL

To install a plug-in unit into one of the plug-in compartments, align the slots in the top and bottom of the plug-in with the associated guide rails in the plug-in compartment. Push the plug-in unit firmly into the plug-in compartment until it locks into place. To remove a plug-in, pull the release latch on the plug-in unit to disengage it and pull the unit out of the plug-in compartment. Plug-in units can be removed or installed without turning off the instrument power.

It is not necessary that all of the plug-in compartments be filled to operate the instrument; the only plug-in units needed are those required for the measurement to be made. However, at environmental extremes, excess radiation may be radiated into or out of this instrument through the open plug-in compartments. Blank plug-in panels are available from Tektronix, Inc., to cover the unused compartment; order Part No.016-0155-00.

When the 7623A is calibrated in accordance with the calibration procedure given in Section 5, the vertical and horizontal gains are standardized. This allows calibrated plug-in units to be changed from one plug-in compartment to another without recalibration. However, the basic calibration of the individual plug-in units should be checked when they are installed in this system to verify their measurement accuracy. See the plug-in unit instruction manual for verification procedure.

Special purpose plug-in units may have specific restrictions regarding the plug-in compartments in which they can be installed. This information will be given in the instruction manual for these plug-in units.

(A)

CONTROLS AND CONNECTORS

The major controls for operation of the 7623A are located on the front panel of the instrument. These are illustrated in Figure 1-2. Figure 1-3 shows the location of rear panel controls and connectors. The following is a brief description of the controls and connectors shown in Figures 1-2 and 1-3. More detailed operating information is given under General Operating Information.

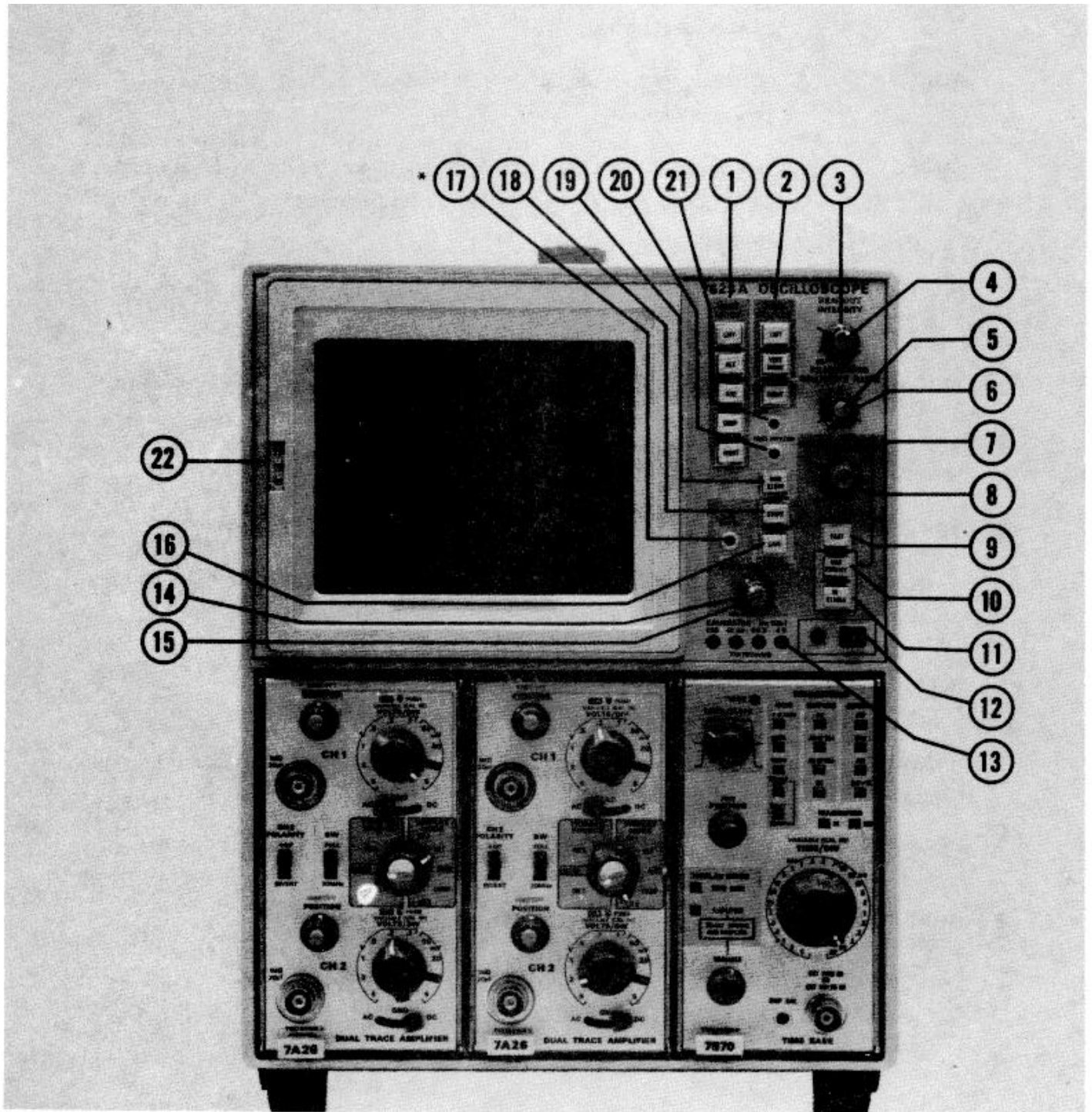

*Changed to INTERNAL ADJUST SN B130000-up

Figure 1-2. Front panel controls and connectors.

Operating Information-7623A/R7623A Service

FRONT PANEL CONTROLS AND CONNECTORS

The following descriptions are referenced to Figure 1-2.

- (1) VERT MODE: Selects vertical mode operation.
 - LEFT: Selects signals from the left vertical amplifier compartment for display.
 - ALT: Selects signals from both vertical compartments for display on alternate sweeps (dual trace).
 - ADD: Algebraically adds the signals from both vertical compartments and displays the sum.
 - CHOP: Selects signals from both vertical compartments for display (dual trace). The display switches between both vertical compartment signals, during the sweep, at a one megahertz rate.
 - RIGHT: Selects signals from the right vertical amplifier compartment for display.
- (2) TRIG SOURCE: Selects the source of the internal trigger for the plug-in unit in the horizontal compartment.
 - LEFT Selects the left vertical compartment as the internal trigger source.
 - VERT MODE: Internal trigger signals are determined by the VERT MODE switch.
 - RIGHT: Selects the right vertical compartment as the internal trigger source.
- (3) INTENSITY-Controls the brightness of the display.
- (4) READOUT-Turns on the Readout system and controls the brightness of the Readout display. (Option 1 deletes this function.)
- (5) BEAMFINDER-When pressed, this switch limits the display to within the graticule area.
- (6) GRATICULE ILLUM-Controls the illumination of the graticule.

(A)

FRONT PANEL CONTROLS AND CONNECTORS (cont.)

- (7) ERASE-Initiates erase cycles; either MANual or PERIODIC.
MANual: When pressed, initiates an erase cycle to erase the stored display and provide a single-shot reset command to the plug-in time-base unit. Operation is locked out in SAVE display mode.
PERIODIC: Controls the time between automatic erase cycles. If the erase period ends during a sweep, the erasure is delayed till the end of that sweep. This control has a counterclockwise OFF detent position. Operation is locked out in the SAVE display mode.
- (8) PERSISTENCE-Controls the view time of the VAR PERSIST and FAST VAR PERSIST stored displays. Operation is locked out in the SAVE display mode.
- (9) FAST-Used in conjunction with the VAR PERSIST and BISTABLE storage selections to choose the fast transfer storage modes of either FAST VAR PERSIST or FAST BISTABLE.
- (10) VAR PERSIST-Selects the Variable Persistence storage mode. The stored display is of variable intensity dependent upon the setting of the STORAGE LEVEL, density of charge deposited when storing, etc. The stored display can be erased at a controllable, continuous rate determined by the setting of the PERSISTENCE control. When not being erased, the view time is limited by the natural bright fading of the storage target.
- (11) BISTABLE-Selects the BISTABLE storage mode. The stored display is substantially of two fixed intensity levels; written (bright) and unwritten (background).An erase cycle returns the display to the unwritten state.
- (12) POWER-Switch and indicator. Switch applies power to the instrument and the indicator illuminates to indicate the power is on.
- (13) CALIBRATOR-Positive going square wave or dc voltage selected by an internal jumper. Output voltage at pin jacks (4 V, 0.4 V, and 40 mV).
- (14) STORAGE LEVEL-Controls the voltage level on the storage targets. Adjusts writing speed in FAST BISTABLE, VAR PERSIST, and FAST VAR PERSIST.
- (15) SAVE INTEN-Used in conjunction with SAVE to control the storage viewing intensity. At reduced intensity, the view time of the stored VAR PERSIST display is proportionately extended.
- (16) SAVE-Selects the SAVE display mode. The stored display is retained at a controllable SAVE INTENSITY and the erase functions are locked out. The time-base unit is inhibited except when the SAVE mode is entered from STORE before a sweep occurs. If this is done, the display will wait in the STORE mode and enter SAVE automatically at the end of the next

(A)

Operating Information-7623A/R7623A Service

FRONT PANEL CONTROLS AND CONNECTORS (cont.)

occurring sweep. This is referred to as the 'babysitting' mode.

- (17) FAST LEVEL CENTER-Adjusts the voltage level of the FAST target relative to the viewing target and, therefore, the tracking of the STORAGE LEVEL for the two targets.(Internal adjustment for instruments SN B130000-up).
- (18) STORE-Selects the STORE display mode.
- (19) NON STORE-Selects conventional display mode. Storage system is inoperative.
- (20) TRACE ROTATE-Adjusts alignment of the trace with the horizontal graticule line.
- (21) FOCUS-Provides adjustment for display definition.
- (22) CAMERA POWER-Three-pin connector on crt bezel provides power output and receives remote single-sweep reset signal from compatible camera systems.

REAR PANEL CONTROLS AND CONNECTORS

The following descriptions are referenced to Figure 1-3.

- (23) FUSE-Line voltage fuse.
- (24) REMOTE ERASE IN-Provides external connection for remote erase.
- (25) EXT SS RESET IN-Remote single sweep reset.
- (26) EXT Z AXIS IN-Input for Intensity modulation of the crt display.
- (27) VERT SIG OUT-Vertical signal selected by TRIG SOURCE switch (LEFT, RIGHT, ALT, and ADD)
- (28) + GATE OUT-Gate signal selected by gate selector switch (Main, Auxiliary, and Delay).
- (29) + SAWTOOTH OUT-Positive-going sawtooth from time-base unit.

REV B, JUNE, 1976

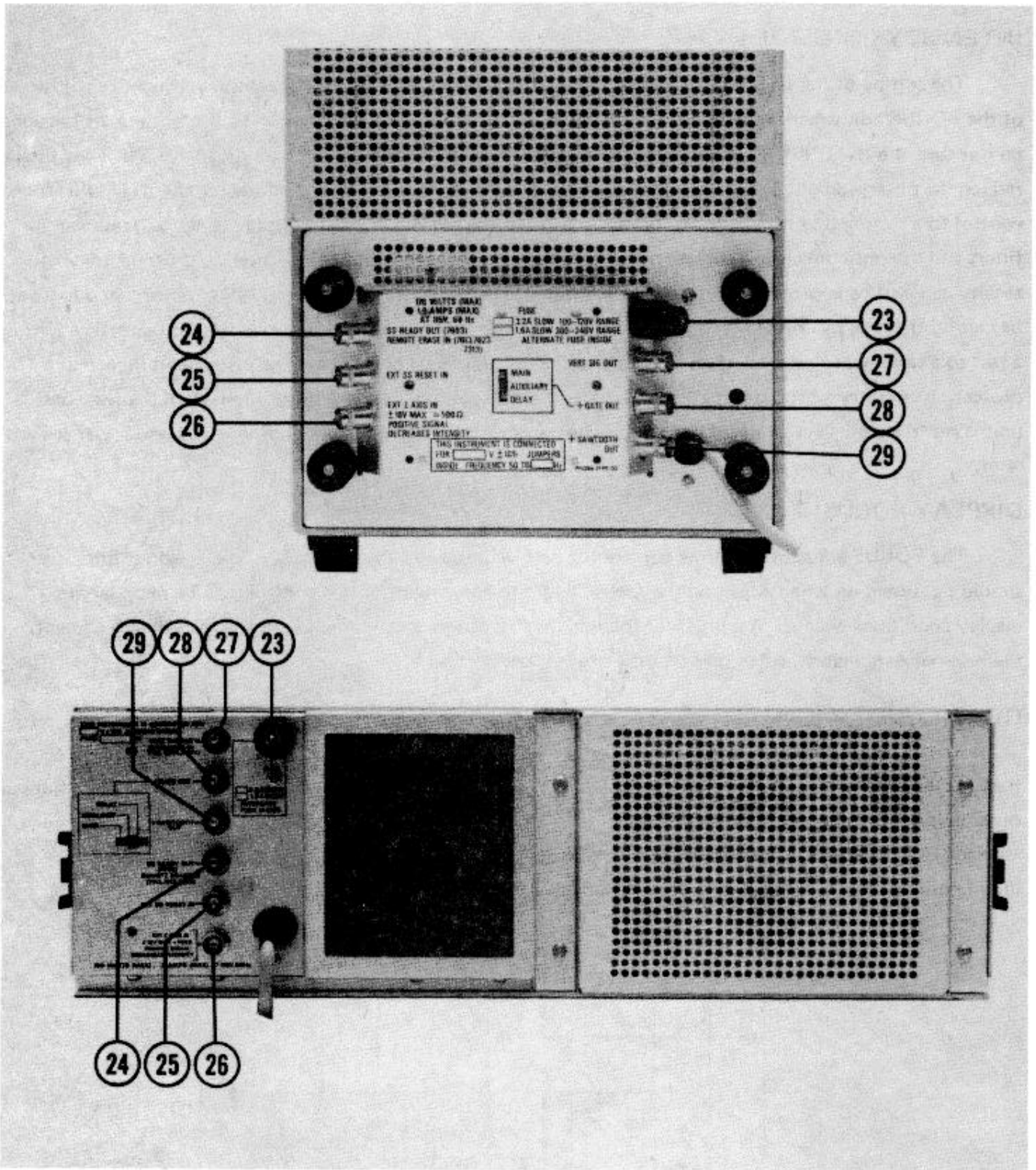

Figure 1-3. Rear panel controls and connectors.

(A)

GENERAL OPERATING INFORMATION

INTENSITY CONTROL

The setting of the INTENSITY control may affect the correct focus of the display. Slight re-adjustment of the FOCUS adjustment may be necessary, when the intensity level is changed. To protect the crt phosphor; do not turn the INTENSITY control higher than necessary to provide a satisfactory display. The light filters reduce the observed light output from the crt. When using these filters, avoid advancing the INTENSITY control to a setting that may burn the phosphor. When the highest intensity display is desired, remove the filters and use only the clear faceplate protector (permanently installed behind bezel). Apparent trace intensity can also be improved in such cases by reducing the ambient light level or using a viewing hood. Also, be careful that the INTENSITY control is not set too high when changing the time-base unit sweep rate from a fast to a slow sweep rate, or when changing to the X-Y mode of operation. The instrument incorporates protection circuitry which automatically reduces the display intensity to a lower level when the time-base unit is set to a slow sweep rate. This reduces the danger of damaging the crt phosphor at these lower sweep rates.

DISPLAY FOCUS

The FOCUS adjustment allows control for best definition of the crt display. The Readout intensity should be turned on when adjusting the focus. Slight re-adjustment of this control may be necessary as display conditions change. If a properly focused display cannot be obtained with the FOCUS adjustment, the internal Astigmatism adjustment must be re-set, see Section 5

GRATICULE

The graticule of the 7623A is marked on the Inside of the faceplate of the crt, providing accurate, non- parallax measurements. The graticule is divided into eight vertical and ten horizontal divisions. Each full scan division is 0.9 centimeter square divided into five minor divisions. The vertical gain and horizontal timing of the plug-in units are calibrated to the graticule so accurate measurements can be made from the crt. The illumination of the graticule lines can be varied with the GRATICULE ILLUM control.

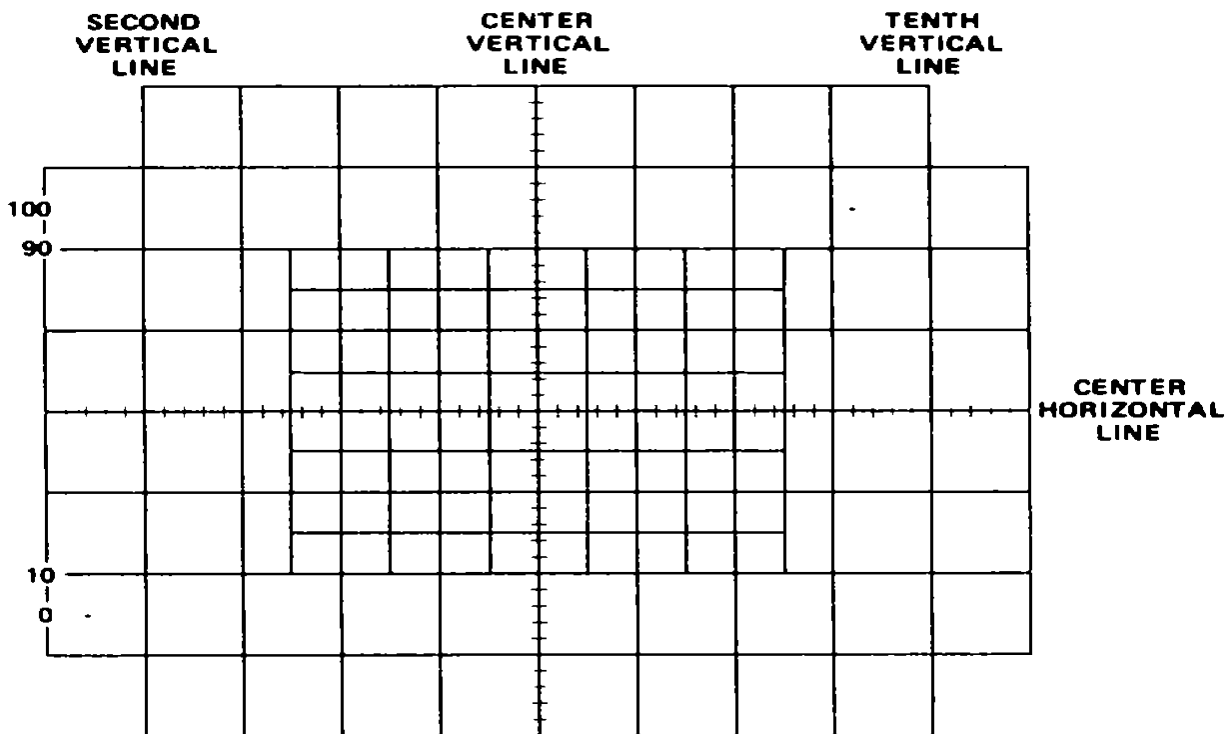

Figure 1-4. Definition of measurement lines on the graticule.

(A)

Fig. 1-4 shows the graticule of the 7623A and defines the various measurement lines. The terminology defined here will be used in all discussions involving graticule measurements. Notice the 0%, 10%, 90%, and 100% markings on the left side of the graticule. These markings are provided to facilitate rise-time measurements.

LIGHT FILTER

The tinted filter provided with the 7623A minimizes light reflections from the face of the CRT to improve contrast when viewing the display under high ambient light conditions. This filter should be removed for waveform photographs or when viewing high writing rate displays. To remove the filter, pull outward on the bottom of the plastic CRT mask and remove it from the CRT bezel. Remove the tinted filter; leave the clear plastic faceplate protector installed and replace the bezel. The faceplate protector should be left in place at all times to protect the CRT faceplate from scratches.

An optional mesh filter is available for use with the 7623A. This filter provides shielding against radiated EMI (electromagnetic interference) from the face of the CRT. It also serves as a light filter to make the trace more visible under high ambient light conditions. The mesh filter fits in place of the plastic CRT mask and the tinted filter. The filter can be ordered by Tektronix Part No. 378-0603-00.

BEAMFINDER

The BEAMFINDER switch provides a means of locating a display which overscans the viewing area either vertically or horizontally. When the BEAMFINDER switch is pressed and held, the display is compressed within the graticule area. Release the BEAMFINDER switch to return to a normal display. To locate and reposition an overscanned display, use the following procedure:

1. Press and hold the BEAMFINDER switch.
2. Increase the vertical and horizontal deflection factors until the vertical deflection is reduced to about two divisions and the horizontal deflection is reduced to about four divisions (the horizontal deflection needs to be reduced only when in the X-Y mode of operation).
3. Adjust the vertical and horizontal position controls to center the display about the vertical and horizontal center lines of the graticule.
4. Release the BEAMFINDER switch, the display should remain within the viewing area.

(A)

Operating Information-7623A/R7623A Service

READOUT MODES (Option 1 deletes)

The characters of the readout display are written by the crt beam on a time-share basis with signal waveforms. The Readout System operates in a free-running mode to randomly interrupt the waveform display to present the readout characters. The Readout System can also operate in a GATE TRIG'D mode, no readout signal is produced until after the sweep has occurred. In this mode the sweep must run to have a readout display. Switch 2110, located on the Readout board, changes the Readout modes. See Figure 1-5 for location of S2110

DISPLAY PHOTOGRAPHY

A permanent record of the crt display can be obtained with an oscilloscope camera system. The instruction manuals for the Tektronix Oscilloscope Cameras include complete Instructions for obtaining waveform photographs. The following information applies only to the 7623A Oscilloscope.

The crt bezel of the 7623A provides integral mounting for Tektronix Oscilloscope Cameras. Three pins, located on the crt bezel, connect power to compatible camera systems. These pins also sense control signals from Tektronix automatic cameras to permit camera-controlled single-shot photography (see the camera manual for further information).

Photographs of waveforms stored in the VAR PERSIST mode are obtained in the same manner as those taken in normal operation. However, to obtain satisfactory photographs of a stored BISTABLE display, it is often necessary to switch into the SAVE mode and use reduced intensity. Figure 1-5. Location of Readout Mode switch.

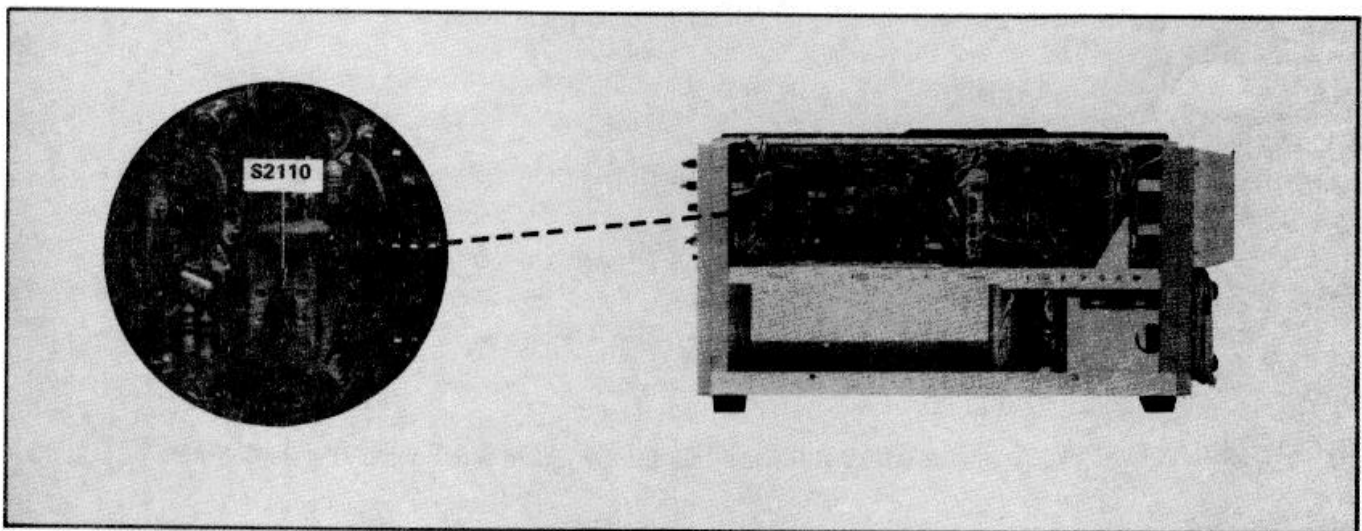

Figure 1-5. Location of Readout Mode switch.

(A)

Operating Information-7623A/R7623A Service

STORAGE

The 7623A Transfer Storage Oscilloscope has four selectable storage modes (listed in order of increasing writing speed): BISTABLE, VAR PERSIST, FAST BISTABLE, and FAST VAR PERSIST. The storage writing speed in all storage modes is affected by the setting of the INTENSITY control. The STORAGE LEVEL control also adjusts writing speed in all storage modes except BISTABLE. The STORAGE LEVEL control adjusts the bias voltage on the Front Mesh in VAR PERSIST mode and on the Fast Mesh in the FAST modes.

Fastest writing speed is obtained with the INTENSITY control set to maximum without blooming the trace and the STORAGE LEVEL set in the two o'clock position.

The erase cycle removes any previous display from the Front (view) Mesh and prepares this mesh for receipt of a waveform. Erase cycles are initiated by pressing the MANUAL knob or by rotating it out of the MAX detent position for PERIODIC erasure. Frequency of PERIODIC ERASE cycles can be controlled in the 2 - 10 second range. If a sweep is in progress when the PERIODIC ERASE cycle occurs, the erase cycle is delayed until the end of sweep. Thus, the PERIODIC ERASE control can be used to set up an erase-after-sweep operation for slower periodic sweeps. A Single Sweep Reset is sent to the time-base unit at the end of each erase cycle. Consequently, if the time-base unit is in the single-sweep mode, it is automatically armed to run once following each erase cycle.

REMOTE ERASE is commanded by a ground closure applied to the rear panel input.

BISTABLE MODE

In the BISTABLE storage mode, the INTENSITY control adjusts for optimum stored display. Slower signals require less intensity to store than faster signals. The STORAGE LEVEL and PERSISTENCE controls do not operate in the BISTABLE mode.

VARIABLE PERSISTENCE MODE

In the VAR PERSIST mode, the INTENSITY and STORAGE LEVEL controls adjust the writing speed and the PERSISTENCE control adjusts the length of time the stored signal is visible before it fades into the background.

FAST MODES

Time-base unit operation is modified by the Storage system in the FAST storage modes to permit individual sweeps to recur at about one second intervals. This permits the Fast Mesh to be prepared between sweeps. After each sweep, the signal is transferred from the Fast Mesh to the Front Mesh for viewing. Then, the Fast Mesh is prepared again for the next sweep and the cycle repeats.

If an erase cycle occurs, Fast Mesh preparation takes place during the erase cycle. However, it is not necessary to ERASE for the sweep and transfer functions to cycle. For instance, if the time-base

(A)

Operating Information-7623A/R7623A' Service

unit is set for single-sweep, multiple sweeps can be stored by pressing the reset button on the time-base unit. If the time-base unit is set for auto triggering, the sweep and transfer functions automatically operate in a cyclical fashion. After each sweep, the display transfers to the Front Mesh for viewing and the Fast Mesh is prepared for the next sweep. Since no erase cycle is generated, multiple sweeps can be stored automatically in this manner. This can be more easily observed if the vertical position is varied between sweeps.

FAST BISTABLE MODE

This mode operates the same as BISTABLE except the display is written on the Fast Mesh and transferred to the Front Mesh for viewing as described above. Therefore, the STORAGE LEVEL control setting affects the stored writing speed.

FAST VARIABLE PERSISTENCE MODE

This mode combines the operation of both VAR PERSIST and FAST BISTABLE. The PERSISTENCE control adjusts the view time, the STORAGE LEVEL adjusts writing speed, and the display will automatically sweep and transfer when the time-base unit is set for auto triggering.

SAVE MODE

The SAVE mode can be entered from either storage mode to retain a stored display indefinitely. The intensity of the stored display in the SAVE mode is adjusted by the SAVE INTEN control. When the SAVE mode is selected, the ERASE function is locked out to prevent erasure of the stored display. Also, the time-base unit is inhibited except when the SAVE mode is entered from STORE before a sweep occurs. If this is done, the display will wait in the STORE mode until a sweep occurs. When a sweep occurs the display will automatically enter SAVE. This is referred to as the 'Babysitting' mode.

CARE OF STORAGE SCREEN

The following precautions will prolong the useful storage life of the crt screen used in this instrument.

1. Use minimum beam intensity to produce a clear, well-defined display.
2. Use minimum SAVE INTEN when storing images for extended periods of time.
3. Avoid repeated use of the same area of the screen. If a particular display is being stored repeatedly, change the vertical position occasionally to use other portions of the display area.

(A)

VERTICAL MODE**LEFT AND RIGHT MODE**

When the LEFT or RIGHT button of the VERT MODE switch is pressed, only the signal from the plug-in unit in the selected compartment is displayed.

ALTERNATE MODE

The ALT position of the VERT MODE switch produces a display which alternates between the plug-in units in the left vertical and right vertical compartments with each sweep of the crt. Although the ALT mode can be used at all sweep rates, the CHOP mode provides a more satisfactory display at sweep rates below about 20 milliseconds/division. At these slower sweep rates, alternate-mode switching becomes visually perceptible.

NOTE

This instrument will not operate in the AL T mode if the horizontal plug-in unit is not operated in the time-base mode.

The TRIG SOURCE switch allows selection of the triggering for an alternate display. When this switch is set to the VERT MODE position, each sweep is triggered by the signal being displayed on the crt. This provides a stable display of two unrelated signals, but does not indicate the time relationship between the signals. In either the LEFT or RIGHT positions of the TRIG SOURCE switch, the two signals are displayed showing true time relationship. However, if the signals are not time-related, the display from the plug-in unit which is not providing a trigger signal will appear unstable on the crt.

CHOPPED MODE

The CHOP position of the VERT MODE switch produces a display which is electronically switched between channels at a one-megahertz rate. In general, the CHOP mode provides the best display at sweep rates lower than about 20 milliseconds/division, or whenever dual-trace single-shot phenomena are to be displayed. At faster sweep rates, the chopped switching becomes apparent and may interfere with the display.

Correct internal triggering for the CHOP mode can be obtained in any of the three positions of the TRIG SOURCE switch. When the TRIG SOURCE switch is set to VERT MODE, the internal trigger signals from the vertical plug-in units are algebraically added and the time-base unit is triggered from the resultant signal. Use of the LEFT or RIGHT trigger-source positions triggers the time-base unit on the internal trigger signal from the selected vertical unit only. This allows two time-related signals to be displayed showing true time relationship. However, if the signals are not time-related, the display for the channel which is not providing the trigger signal will appear unstable. The CHOP mode can be used to compare two single-shot, transient, or random signals which occur within the time interval determined by the time-base unit (ten times selected sweep rate). To provide correct triggering, the display which provides the trigger signal must precede the second display in time. Since the signals show true time-relationship, time-difference

(A)

Operating Information-7623A/R7623A Service

measurements can be made from the display.

ALGEBRAIC ADDITION

The ADD position of the VERT MODE switch can be used to display the sum or difference of two signals, for common-mode rejection to remove an undesired signal, or for dc offset (applying a dc voltage to one channel to offset the dc component of a signal on the other channel). The common-mode rejection ratio between the vertical plug-in compartments of the 7623A is greater than 20:1 at 50 megahertz. The rejection ratio increases to 100:1 at dc.

The overall deflection factor on the crt in the ADD mode is the resultant of the algebraic addition of the signals from the two vertical plug-in units. It is difficult to determine the voltage amplitude of the resultant display unless the amplitude of the signal applied to one of the plug-in units is known. This is particularly true when the vertical units are set to different deflection factors, since it is not obvious which portion of the display is a result of the signal applied to either plug-in unit. Also, the polarity and repetition rate of the applied signals enters into the calculation.

The following general precautions should be observed to provide the best display when using the ADD mode:

1. Do not exceed the input voltage rating of the plug-in units.
2. Do not apply large signals to the plug-in inputs. A good rule to follow is not to apply a signal which exceeds an equivalent of about eight times the vertical deflection factors. For example, with a vertical deflection factor of 0.5 volt/division, the voltage applied to that plug-in unit should not exceed 4 volts. Larger voltages may result in a distorted display.
3. To ensure the greatest dynamic range in the ADD mode, set the position controls of the plug-in units to a setting which would result in a mid-screen display if viewed in the LEFT or RIGHT positions of the VERT MODE switch.
4. For similar response from each channel, set the plug-in units for the same input coupling.

TRIGGER SOURCE

The TRIG SOURCE switch allows selection of the internal trigger signal for the time-base unit. For most applications, this switch can be set to the VERT MODE position. This position is the most convenient, since the internal trigger signal is automatically switched as the VERT MODE switch is changed, or as the display is electronically switched between the left vertical and right vertical plug-in units in the ALT position of the VERT MODE switch. It also provides a usable trigger signal in the ADD or CHOP positions of the VERT MODE switch, since the internal trigger signal in these modes is the algebraic sum of the signals applied to the vertical plug-in units. Therefore, the VERT MODE position ensures that the time-base unit receives a trigger signal regardless of the VERT MODE switch setting, without the need to change the trigger source selection.

(A)

If correct triggering for the desired display is not obtained in the VERT MODE position, the LEFT or RIGHT positions can be used to obtain the trigger signal from either the left vertical or right vertical plug-in unit. The internal trigger signal is obtained from the selected vertical compartment, whether the plug-in unit in that compartment is selected for display on the crt or not. If the internal trigger signal is obtained from one of the vertical units, but the other vertical unit is selected for display, the internal trigger signal must be time-related to the displayed signal in order to obtain a triggered (stable) display.

X-Y OPERATION

For some applications, it is desirable to display one signal versus another (X-Y) rather than against time (internal sweep). The flexibility of the plug-in units available for use with the 7623A provides a means for applying an external signal to the horizontal deflection system for this type of display. Some of the 7B-series time-base units can be operated as amplifiers in addition to their normal use as time-base generators. This feature allows an external signal to provide the horizontal deflection on the crt. For most of the time-base units with the amplifier function, the X (horizontal) signal can be connected either to an external input connector on the time-base unit or it can be routed to the time-base unit through the internal triggering system (see time-base instruction manual for details). If the latter method is used, the TRIG SOURCE switch must be set so that the X (horizontal) signal is obtained from one of the vertical units and the Y (vertical) signal is obtained from the other vertical unit. The advantages of using the internal trigger system to provide the X signal are that the attenuator switch of the amplifier unit providing the horizontal signal determines the horizontal deflection factor to allow full-range operation. The plug-in units do not have to be removed between compartments when X-Y operation is desired.

Another method of obtaining an X-Y display is to install an amplifier plug-in unit in the horizontal plug-in compartment (check amplifier unit gain as given in the plug-in instruction manual to obtain calibrated horizontal deflection factors). This method provides the best X-Y display, particularly if two identical amplifier units are used, since both the X and Y input systems will have the same delay time, gain characteristics, input coupling, etc. For further information on obtaining X-Y displays, see the plug-in unit manuals. Also, the reference books listed under Applications provide information on X-Y measurements and interpreting the resultant lissajous displays.

INTENSITY MODULATION

Intensity (Z-axis) modulation can be used to relate a third item of electrical phenomena to the vertical (Y-axis) and the horizontal (X-axis) coordinates without affecting the waveshape of the displayed signal. The Z-axis modulating signal applied to the crt circuit changes the intensity of the displayed waveform to provide this type of display. Gray scale intensity modulation can be obtained by applying signals which do not completely blank the display. Large amplitude signals of the correct polarity will completely blank the display; the sharpest display is provided by signals with a fast risetime and fall. The voltage amplitude required for visible trace modulation depends upon the setting of the INTENSITY control. A two-volt peak-to-peak signal will completely blank the display even at high intensity levels. Lower amplitude signals can be used to only change the trace brightness rather than completely blank the display. Negative-going modulating signals increase the display intensity and positive-going modulating signals decrease the

Operating Information-7623A/R7623A Service

display intensity. Useful input frequency range is dc to 10 megahertz (input voltage derating necessary above two megahertz). The maximum input voltage should be limited to 10 volts (dc plus peak ac).

Time markers applied to the EXT Z AXIS input connector provide a direct time reference on the display. With uncalibrated horizontal sweep or external horizontal mode operation, the time markers provide a means of reading time directly from the display. However, if the markers are not time-related to the displayed waveform, a single-sweep display should be used (for internal sweep only) to provide a stable display.

RASTER DISPLAY

A raster-type display can be used to effectively increase the apparent sweep length. For this type of display, the trace is deflected both vertically and horizontally by sawtooth signals. This is accomplished in the 7623A by installing a 7B-series time-base unit in one of the vertical plug-in compartments. Normally, the time-base unit in the vertical compartment should be set to a slower sweep rate than the time-base unit in the horizontal compartment, the number of horizontal traces in the raster depends upon the ratio between the two sweep rates. Information can be displayed on the raster using several different methods. In the ADD position of the VERT MODE switch, the signal from an amplifier unit can be algebraically added to the vertical deflection. With this method, the vertical signal amplitude on the crt should not exceed the distance between the horizontal lines of the raster. Another method of displaying information on the raster is to use the EXT Z AXIS input to provide intensity modulation of the display. This type of raster display could be used to provide a television-type display. Complete information on operation using the Z-axis feature is given under Intensity Modulation.

To provide a stable raster display, both time-base units must be correctly triggered. Internal triggering is not provided for the time-base units when they are in the vertical compartments; external triggering must be used. Also, blanking is not provided from the time-base units when they are installed in a vertical compartment. To blank out the retrace portion from the time-base unit in the vertical compartment, special connections must be made from this time-base unit to the blanking network of the 7623A. If this mode of operation is desirable, contact your local Tektronix Field Office or representative for specific information on obtaining blanking with the specific time-base unit being used in the vertical compartment.

CALIBRATOR

GENERAL

The internal calibrator of the 7623A provides a convenient signal source for checking basic vertical gain and for adjusting probe compensation as described in the probe instruction manual. In addition, the calibrator can be used as a convenient signal source for application to external equipment.

VOLTAGE

The calibrator provides accurate output voltages of 40 millivolts, 0.4 volt, and 4 volts at the three front-panel pin-jack connectors into high-impedance loads. Output resistance is approximately 50 ohms

(A)

at the 40 mV and 0.4 V pin jacks and approximately 450 ohms at the 4 V pin jack.

CURRENT

A 40-milliampere, one-kilohertz output current is provided when the optional current-loop accessory (Tektronix Part No.012-0259-00) is connected between the 4 V pin jack and ground. This output can be used to check and calibrate current-measuring probe systems.

WAVESHAPE

The square-wave output signal of the calibrator can be used as a reference waveshape when checking or adjusting the compensation of passive, high-resistance probes. Since the square-wave output from the calibrator has a flat top, any distortion in the displayed waveform is due to the probe compensation. Dc voltage output is also available by changing a jumper on the calibrator board; see Figure 1-6.

SIGNALS OUT

VERTICAL SIGNAL

The VERT SIG OUT connector provides a sample of the vertical deflection signal. The source of the output signal is determined by the TRIG SOURCE switch. The source will follow the setting of the TRIG SOURCE switch. When the TRIG SOURCE is in the VERT MODE the output will follow the VERTICAL MODE switch. In the CHOP mode the signals are added. The output signals are LEFT, ALT, ADD, and RIGHT. The output signal into 50 ohms is about 25 millivolts/division of the vertical signal displayed on the crt. The output into one megohm is about 0.5 volt/division of the vertical signal displayed.

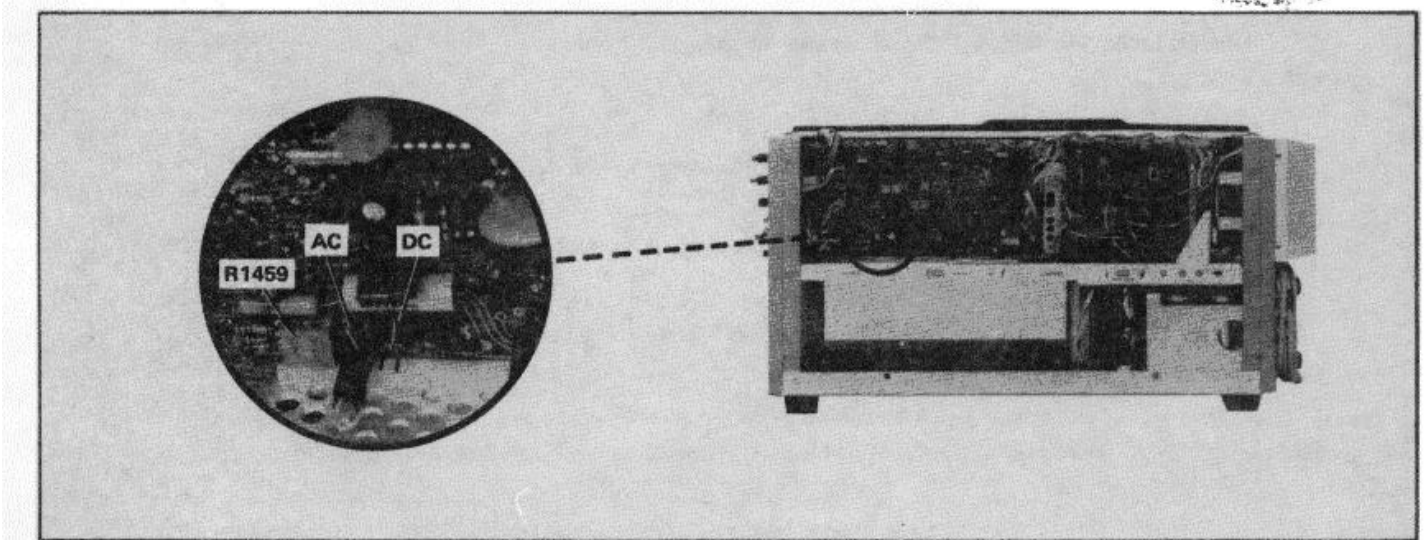

Figure 1-6. Location of Calibrator Jumper on Storage circuit board.

(A)

Operating Information-7623A/R7623A'Service

+ GATE

The + GATE connector provides a sweep gate signal that is generated by the time-base plug-in unit. The gate selector switch provides one of three possible gates (MAIN, AUXILIARY, and DELAY). The duration of the gate pulse is determined by the respective sweep. Auxiliary and Delay gates can only be produced by dual sweep time-base plug-in units. The amplitude of the gate signal is about 50 millivolts into 50 ohms or 10 volts into 1 megohm.

+ SAWTOOTH

The SAWTOOTH connector provides a positive going sample of the sawtooth from the time-base unit in the horizontal compartment. The rate of rise of the sawtooth signal is about 50 millivolts/unit of time into 50 ohms or 1 volt/unit of time into 1 megohm. Unit of time is determined by the time/division3 switch of the horizontal plug-in unit.

APPLICATIONS

The 7623A Oscilloscope and its associated plug-in units provide a very flexible measurement system. The capabilities of the overall system depend mainly upon the plug-in units that are chosen for use with this instrument. Specific applications for the individual plug-in units are described in the plug-in manuals. The overall system can also be used for many applications which are not described in detail either in this manual or in the manuals for the individual plug-in units. Contact your local Tektronix Field Office or representative for assistance in making specific measurements with this instrument.

The following books describe oscilloscope measurement techniques which can be adapted for use with this instrument.

John D. Lenk, 'Handbook of Oscilloscopes, Theory, and Application', Prentice-Hall Inc., Englewood Cliffs, New Jersey, 1968.

J. Czech, 'Oscilloscope Measuring Techniques', Springer-Verlag, New York, 1965.

J.F. Golding, 'Measuring Oscilloscopes', Transatlantic Arts, Inc., 1971.

Charles H. Roth Jr., 'Use of the Oscilloscope', A Programmed Text, Prentice-Hall Inc., Englewood Cliffs, New Jersey, 1970.

(A)

SPECIFICATIONS

INTRODUCTION

The Tektronix 7623A Storage Oscilloscope is a solid-state, high-performance instrument designed for fast writing rate storage applications. This instrument accepts Tektronix 7-series plug-in units to form a complete measurement system. The flexibility of this plug-in feature and the variety of plug-in units available allow the system to be used for many measurement applications.

This Instrument will meet the electrical characteristics listed in the Performance Requirement column of Table 2-1 following complete calibration as given in the Service manual. The following characteristics apply over an ambient temperature range of OOC to +500C, except as otherwise indicated. Warmup time for given accuracy is 30 minutes.

NOTE

Many of the measurement capabilities of this instrument are determined by the choice of plug-in units. The following characteristics apply to the 7623A Storage Oscilloscope only. See the System Specifications later in this section for characteristics of the complete system.

TABLE 2-1
ELECTRICAL

Characteristic	Performance Requirement	Supplemental Information
	VERTICAL DEFLECTION SYSTEM	
Deflection Factor	Compatible with all 700(-series plug-in units.	
Between Compartments	Within 1%.	
Low Frequency Linearity	0.1 division or less compression or expansion of a 2-division (at center-screen) signal when positioned vertically within the graticule area.	
Bandwidth	See System Specifications for 7600-series instruments.	
Step Response Risetime	See System Specifications for	
7600-series instruments.		
Isolation Between Vertical Compartments	At least 100 1 from DC to 100 MHz.	

(A)

TABLE 2-1 (cont.)
ELECTRICAL

Characteristic	Performance Requirement	Supplemental Information
Delay Line		Permits viewing leading edge of trigger signal.
Chopped Mode Repetition Rate Time Segment From Each Compartment		1 MHz within 20%. 0.4 to 0.6 μ s.
Difference in Delay Between Vertical Compartments		0.5 ns or less.
Vertical Display Modes	LEFT Left vertical unit only. ALT Dual trace, alternate between vertical units. ADD' Added algebraically. CHOP. Dual trace, chopped between vertical units. RIGHT Right vertical unit only.	Selected by VERT MODE switch.
TRIGGERING		
Trigger Source	LEFT VERT From left vertical only. VERT MODE: Determined by vertical mode switch. RIGHT VERT: From right vertical only.	Selected by TRIGGER SOURCE switch.
HORIZONTAL DEFLECTION SYSTEM		
Fastest Calibrated Sweep Rate	5 ns/division.	
Deflection Factor	Compatible with all 7000-series plug-in units.	

TABLE 2-1 (cont.)
ELECTRICAL

Characteristic	Performance Requirement	Supplemental Information
Low Frequency Linearity	0.1 division or less compression or expansion of a 2-division (at center-screen) signal when positioned horizontally within the graticule area.	
Phase Shift Between The Vertical and Horizontal Amplifiers	Less than 20 from dc to 35 kHz.	
Frequency Response Bandwidth (8-Division Reference)	At least 2 MHz.	
CALIBRATOR		
Wave shape	Positive-going square wave or dc (dc voltage selected by internal jumper).	
Voltage Outputs	40 mV, 0.4 V, and 4 V.	Into 1 MΩ load.
Voltage Output Accuracy +150C to +350C	Within 1%.	
0°C to +500C	Within 2%.	
Current Output	40 mA.	
Current Output Accuracy +150C to +350C	Within 2%.	Within optional current loop accessory (012-0259-00) connected between 4 V pin jack and ground pin jack.
0°C to +50°C	Within 3%.	
Repetition Rate		Approximately 1 kHz.
Output Resistance		
50 mV and 0.4 V		Approximately 50Ω.
4 V		Approximately 450Ω

(A)

TABLE 2-1 (cont.)
ELECTRICAL

Characteristic	Performance Requirement	Supplemental Information
<p>Camera Power (P1041 at crt bezel)</p> <p>Pin 1 - +15 V</p> <p>Pin 3 - single sweep reset</p> <p>Pin 5 - ground</p> <p>EXTERNAL Z AXIS INPUT Sensitivity (Full Intensity Range)</p> <p>Useful Input Voltage Versus Frequency</p> <p>Polarity of Operation Maximum Input Voltage Input Resistance</p>	<p style="text-align: center;">OUTPUTS</p> <p>2 V peak to peak.</p> <p>2 V peak to peak, dc to 2 MHz, reducing to 0.4 V peak to peak at 10 MHz.</p> <p>Positive-going signal decreases Intensity.</p>	<p>10 V (dc + peak ac). Approximately 500 Ω.</p>
	<p>CHARACTER GENERATOR</p>	
<p>Character Size Modes of Operation</p>	<p>Adjustable (Vertically Only).i Free-run independent of sweep. Triggered after sweep.</p>	<p>Selected by internal Readout mode switch.</p>
	<p>POWER SOURCE</p>	
<p>Line Voltage Ranges 110 V nominal 100 V ± 10%.</p>	<p>110 V ± 10%. 120 V ± 10%.</p>	

TABLE 2-1 (cont.)
ELECTRICAL

Characteristic	Performance Requirement	Supplemental Information
Line Voltage Ranges 220 V nominal	200 V ± 10%. 220 V ± 10%. 240 V ± 10%.	
Line Frequency		50 to 60 Hz.
Maximum Power Consumption (115 Vac ;60 Hz)		7623A.170 W, 1.9 A.
		R7623A' 180 W, 2 A.
Fuse Data 110 V line (F1000) 220 V line (F1000) +130 V Supply (F855) +15 V unregulated		3.2 A slow blow. 1.6 A slow blow. 0.15 A fast blow. 2.0 A fast blow.
DISPLAY (CRT)		
Cathode-Ray Tube Type Graticule Type Area Division Phosphor Accelerating Potential	T7411. Internal and illuminated. 8 x 10 divisions 0.9 centimeter P31 Approximately 8.5 kV	
BEAMFINDER	Limits display to within graticule area when BEAMFINDER switch is actuated.	

(A)

TABLE 2-1 (cont.)
ELECTRICAL

Characteristic	Performance Requirement	Supplemental Information
Stored Writing Speed (center 6 x 8 divisions) FAST VAR PERSIST FAST BISTABLE VAR PERSIST BISTABLE	150 div/μs 50 div/μs 0.5 div/μs 0.03 div/μs	
SIGNALS OUT		
VERT SIG OUT Vertical Signals Gain Into 50Ω Into 1 MΩ SIG OUT. Risetime (Into 50 Ω) Centering Output Resistance	See Systems Specifications for 7600-series instruments LEFT, RIGHT, ALT and ADD	Selected by TRIG SOURCE switch. 25 mV/division ± 20% system crt to VERT SIG OUT. 0.5 V/division ± 20% system crt to VERT 5 ns or less ±3 division system crt to VERT SIG OUT.(1.5V into 1 MΩ or 75 mV into 50 Ω.) 950 Ω ± 2% within 2%.

(A)

TABLE 2-1 (cont.)
ELECTRICAL

Characteristic	Performance Requirement	Supplemental Information
+GATE OUT		
Gate Signals	MAIN, AUXILIARY, and DELAY.	Selected by Gate Selector switch.
Output		
Into 50 Ω	0.5 V within 10%.	
Into 1 MΩ	10 V within 10%.	
Risetime (Into 50 Ω)	20 ns or less.	
Output Resistance	950 Q within 2%.	
+SAWTOOTH OUT		
Output		
Into 50Ω		50 mV/unit time ¹ within 15%.
Into 1 MΩ		1 V/unit time ¹ within 10%.
Output Resistance		950 Ω within 2%.
ELECTRO-MAGNETIC INTERFERENCE		
Electro-magnetic interference(emi) in accordance with MIL-STD-461A as tested in MIL-STD-462 (when equipped with Option 3)	Any unused plug-in compartments must be covered with a blank plug-in panel (emi shielded) in order to meet emi specifications. See Options section for additional information.	
Radiated Interference	Interference radiated from the instrument under test within the given limits from 150 kilohertz to 1000 megahertz.	
Conducted interference	Interference conducted out of the instrument under test through the power cord within the given limits from 150 kilohertz to 25 megahertz.	
Transportation (packaged instrument, without plug-ins)	Qualifies under National Safe Transit Committee test procedure 1A, Category II.	

¹Referred to Time/Div setting

(A)

Specifications-7623A/R7623A Service

*TABLE 2-2
ENVIRONMENTAL*

Characteristic	Information
NOTE <i>This instrument will meet the electrical characteristics given in the Performance Requirement column of the Specifications over the following environmental limits.</i>	
Temperature Range	
Operating	0°C to +500C.
Non-Operating	-550C to +750C.
Altitude	
Operating	15, 000 ft.
Non-Operating	Test limit 50, 000 ft.

Transportation (packaged instrument, without plug-in units) qualifies under National Safe Transit test procedure 1A, Category II.

*TABLE 2-3
PHYSICAL*

Characteristic	Information
Ventilation	Safe operating temperature maintained by forced cooling. Automatic resetting thermal cutout protects instrument from overheating.
Finish	Anodized aluminum front panel. Painted cabinet.
7623A Overall Dimensions (measured at maximum point)	
Height	12.0 in (30.4 cm).
Width	8.7 in (23.0 cm).
Length	23.7 in (50.2 cm).
Net Weight (instrument only)	30 lb (13.6 kg).

(A)

TABLE 2-3 (cont)
PHYSICAL

Characteristic	Information
R7623A Overall Dimensions (measured at maximum points)	
Height	5.25 in (13.4 cm).
Width	19 in (48.3 cm).
Length	23 in (57.96 cm).
Net Weight (instrument only)	30 lb (13.6 kg).

STANDARD ACCESSORIES

Standard accessories supplied with the 7623A are given in the Mechanical Parts List. For optional accessories available for use with this instrument, see the Tektronix, Inc., catalog.

(A)

Specifications-7623A/R7623A Service

TABLE 2-4
7623A SYSTEM SPECIFICATIONS

Amplifier Plug-In Unit	Probe	Bandwidth	Risetime (Calculated)	Accuracy *			SIG OUT	
				EXT CAL INT CAL			BW	T _r
				0.25% Acc	15 to 360 C	0 to 500 C		
7A11	Integral	100 MHz	3.5 ns	2%	3%	4%	60 MHz	5.9 ns
7A12	None	80 MHz	4.4 ns	2%	3%	4%	55 MHz	6.4 ns
	P6053B	80 MHz	4.4 ns	3%	4%	5%	55 MHz	6.4 ns
7A13	None or P6055	75 MHz	4.7 ns	1.5%	2.5%	3.5%	55 MHz	6.4 ns
		55 MHz	6.4 ns	1.5%	2.5%	3.5%	45 MHz	7.8 ns
7A14	P86021	50 MHz	7.0 ns	2%	3%	4%	40 MHz	8.8 ns
	P6022	80 MHz	4.7 ns	2%	3%	4%	50 MHz	7.0 ns
7A15A	None	65 MHz	5.4 ns	2%	4%	5%	50 MHz	7.0 ns
	P6065A	60 MHz	5.4 ns	3%	4%	5%	50 MHz	7.0 ns
7A16A	None	100 MHz	3.5 ns	2%	3%	4%	60 MHz	5.9 ns
	P6053B	100 MHz	3.5 ns	3%	4%	5%	60 MHz	5.9 ns
7A17	None	100 MHz	3.5 ns				15 MHz	24 ns
7A18	None	75 MHz	4.7 ns	2%	3%	4%	50 MHz	7.0 ns
	P6065A	70 MHz	4.7 ns	3%	4%	5%	50 MHz	7.0 ns
7A19	None	100 MHz	3.5 ns	3%	4%	5%	65 MHz	5.4 ns
	P6056/ P6057	100 MHz	3.5 ns	4%	5%	6%	65 MHz	5.4 ns
7A22	None P60551or P6060	1.0 MHz, ±10%	350 ns ±9%	2%	3%	4%	1.0 MHz, ±10%	350 ns ±9%
7A24	None	100 MHz	3.5 ns				60 MHz	5.9 ns
	P6056/ P6057	100 MHz	3.5 ns				60 MHz	5.9 ns
7A26	None	100 MHz	3.5 ns	2%	3%	4%	60 MHz	5.9 ns
	P6053B	100 MHz	3.5 ns	3%	4%	5%	60 MHz	5.9 ns

* Deflection Factor Accuracy. Plug-in gain set at a temperature within 10°C of the operating temperature.

Bandwidth checked from 0 C to +500 C.

The bandwidth of a vertical plug-in used in the horizontal compartment is 2 MHz except for the 7A22 which has a bandwidth of 850 kHz. The X-Y phase shift between 2 similar units is 20 at 35 kHz.

(A)

THEORY OF OPERATION

This section begins with a brief discussion of logic fundamentals followed by a general, block diagram description and a detailed description of the circuits that comprise the 7623A Oscilloscope. The circuit description is keyed to the schematic diagrams located in the diagrams section of this manual. Circuits commonly used in the electronics industry are not described in detail. If more information on these circuits is desired, refer to the following textbooks:

Robert C. Baron and Albert T. Piccirilli, 'Digital Logic and Computer Operation', McGraw-Hill, New York, 1967

Phillip Cutler, 'Semiconductor Circuit Analysis', McGraw-Hill, New York, 1964

Lloyd P. Hunter (Ed.), 'Handbook of Semiconductor Electronics', second edition, McGraw-Hill, New York, 1962.

Jacob Millman and Herbert Taub, 'Pulse, Digital, and Switching Waveforms', McGraw-Hill, New York, 1965

(A)

LOGIC FUNDAMENTALS

Digital logic techniques are used to perform many functions within this instrument. The function and-J operation of the logic circuits are described using logic symbology and terminology. This portion of the manual is provided to aid in the understanding of these symbols and terms. The following information is a basic introduction to logic concepts.

SYMBOLS

The operation of circuits within the 7623A which use digital techniques is described using the graphic symbols set forth in military standard MIL-STD-806B. Table 3-1 provides a basic logic reference for the logic devices used within this instrument. Any deviations from the standard symbology, or devices not defined by this standard will be described in the circuit description for the applicable device.

TABLE 3-1
Basic Logic Reference









Device	Symbol	Description	Input/Output Table																		
AND gate		A device with two or more inputs and one output. The output of the AND gate is HI if and only if all of the inputs are at the HI state.	<table border="1"> <thead> <tr> <th colspan="2">Input</th> <th>Output</th> </tr> <tr> <th>A</th> <th>B</th> <th>X</th> </tr> </thead> <tbody> <tr> <td>LO</td> <td>LO</td> <td>LO</td> </tr> <tr> <td>LO</td> <td>HI</td> <td>LO</td> </tr> <tr> <td>HI</td> <td>LO</td> <td>LO</td> </tr> <tr> <td>HI</td> <td>HI</td> <td>HI</td> </tr> </tbody> </table>	Input		Output	A	B	X	LO	LO	LO	LO	HI	LO	HI	LO	LO	HI	HI	HI
Input		Output																			
A	B	X																			
LO	LO	LO																			
LO	HI	LO																			
HI	LO	LO																			
HI	HI	HI																			
NAND gate		A device with two or more inputs and one output. The output of the NAND gate is LO if and only if all of the inputs are at the HI state.	<table border="1"> <thead> <tr> <th colspan="2">Input</th> <th>Output</th> </tr> <tr> <th>A</th> <th>B</th> <th>X</th> </tr> </thead> <tbody> <tr> <td>LO</td> <td>LO</td> <td>HI</td> </tr> <tr> <td>LO</td> <td>HI</td> <td>HI</td> </tr> <tr> <td>HI</td> <td>LO</td> <td>HI</td> </tr> <tr> <td>HI</td> <td>HI</td> <td>LO</td> </tr> </tbody> </table>	Input		Output	A	B	X	LO	LO	HI	LO	HI	HI	HI	LO	HI	HI	HI	LO
Input		Output																			
A	B	X																			
LO	LO	HI																			
LO	HI	HI																			
HI	LO	HI																			
HI	HI	LO																			
OR gate		A device with two or more inputs and one output. The output of the OR gate is HI if one or more of the inputs are at the HI state.	<table border="1"> <thead> <tr> <th colspan="2">Input</th> <th>Output</th> </tr> <tr> <th>A</th> <th>B</th> <th>X</th> </tr> </thead> <tbody> <tr> <td>LO</td> <td>LO</td> <td>LO</td> </tr> <tr> <td>LO</td> <td>HI</td> <td>HI</td> </tr> <tr> <td>HI</td> <td>LO</td> <td>HI</td> </tr> <tr> <td>HI</td> <td>HI</td> <td>HI</td> </tr> </tbody> </table>	Input		Output	A	B	X	LO	LO	LO	LO	HI	HI	HI	LO	HI	HI	HI	HI
Input		Output																			
A	B	X																			
LO	LO	LO																			
LO	HI	HI																			
HI	LO	HI																			
HI	HI	HI																			
NOR gate		A device with two or more inputs and one output. The output of the NOR gate is LO if one or more of the inputs are at the HI state.	<table border="1"> <thead> <tr> <th colspan="2">Input</th> <th>Output</th> </tr> <tr> <th>A</th> <th>B</th> <th>X</th> </tr> </thead> <tbody> <tr> <td>LO</td> <td>LO</td> <td>HI</td> </tr> <tr> <td>LO</td> <td>HI</td> <td>LO</td> </tr> <tr> <td>HI</td> <td>LO</td> <td>LO</td> </tr> <tr> <td>HI</td> <td>HI</td> <td>LO</td> </tr> </tbody> </table>	Input		Output	A	B	X	LO	LO	HI	LO	HI	LO	HI	LO	LO	HI	HI	LO
Input		Output																			
A	B	X																			
LO	LO	HI																			
LO	HI	LO																			
HI	LO	LO																			
HI	HI	LO																			

TABLE 3-1 (cont)

Device	Symbol	Description	Input/Output Table																																				
Inverter		A device with one input and one output. The output state is always opposite to the input state.	<table border="1"> <thead> <tr> <th colspan="2">Input</th> <th>Output</th> </tr> <tr> <th>A</th> <th></th> <th>X</th> </tr> </thead> <tbody> <tr> <td>LO</td> <td></td> <td>HI</td> </tr> <tr> <td>HI</td> <td></td> <td>LO</td> </tr> </tbody> </table>	Input		Output	A		X	LO		HI	HI		LO																								
Input		Output																																					
A		X																																					
LO		HI																																					
HI		LO																																					
LO-state indicator	  	<p>A small circle at the input or output of a symbol indicates that the LO state is the significant state. Absence of the circle indicates that the HI state is the significant state. Two examples follow</p> <p>AND gate with LO-state indicator at the A input.</p> <p>The output of this gate is HI if and only if the A input is LO and the B input is HI.</p> <p>OR gate with LO-state indicator at the A input</p> <p>The output of this gate is HI if either the A input is LO or the B input is HI</p>	<table border="1"> <thead> <tr> <th colspan="2">Input</th> <th>Output</th> </tr> <tr> <th>A</th> <th>B</th> <th>X</th> </tr> </thead> <tbody> <tr> <td>LO</td> <td>LO</td> <td>LO</td> </tr> <tr> <td>LO</td> <td>HI</td> <td>HI</td> </tr> <tr> <td>HI</td> <td>LO</td> <td>LO</td> </tr> <tr> <td>HI</td> <td>HI</td> <td>LO</td> </tr> </tbody> </table> <table border="1"> <thead> <tr> <th colspan="2">Input</th> <th>Output</th> </tr> <tr> <th>A</th> <th>B</th> <th>X</th> </tr> </thead> <tbody> <tr> <td>LO</td> <td>LO</td> <td>HI</td> </tr> <tr> <td>LO</td> <td>HI</td> <td>HI</td> </tr> <tr> <td>HI</td> <td>LO</td> <td>LO</td> </tr> <tr> <td>HI</td> <td>HI</td> <td>HI</td> </tr> </tbody> </table>	Input		Output	A	B	X	LO	LO	LO	LO	HI	HI	HI	LO	LO	HI	HI	LO	Input		Output	A	B	X	LO	LO	HI	LO	HI	HI	HI	LO	LO	HI	HI	HI
Input		Output																																					
A	B	X																																					
LO	LO	LO																																					
LO	HI	HI																																					
HI	LO	LO																																					
HI	HI	LO																																					
Input		Output																																					
A	B	X																																					
LO	LO	HI																																					
LO	HI	HI																																					
HI	LO	LO																																					
HI	HI	HI																																					
Edge symbol		Normally superimposed on an input line to a logic symbol. Indicates that this input (usually the trigger input of a flip-flop) responds to the indicated transition of the applied signal.																																					
Triggered (toggle) Flip-Flop		A bistable device with one input and two outputs (either or both outputs may be used). When triggered, the outputs change from one stable state to the other stable state with each trigger. The outputs are complementary (i.e., when one output is HI the other is LO). The edge symbol on the trigger (T) input may be of either polarity depending on the device.	<table border="1"> <thead> <tr> <th colspan="2">Input</th> <th colspan="2">Output</th> </tr> <tr> <th>Condition before trigger pulse</th> <th>Condition after trigger pulse</th> <th></th> <th></th> </tr> </thead> <tbody> <tr> <td>X</td> <td>X</td> <td>X</td> <td>X</td> </tr> <tr> <td>LO</td> <td>HI</td> <td>HI</td> <td>LO</td> </tr> <tr> <td>HI</td> <td>LO</td> <td>LO</td> <td>HI</td> </tr> </tbody> </table>	Input		Output		Condition before trigger pulse	Condition after trigger pulse			X	X	X	X	LO	HI	HI	LO	HI	LO	LO	HI																
Input		Output																																					
Condition before trigger pulse	Condition after trigger pulse																																						
X	X	X	X																																				
LO	HI	HI	LO																																				
HI	LO	LO	HI																																				

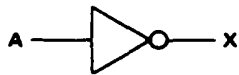
(A)

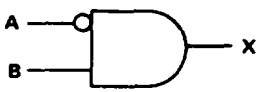
TABLE 3-1 (cont)

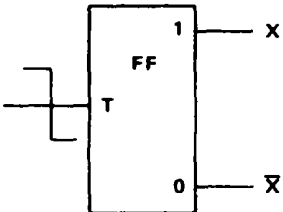
Device	Symbol	Description	Input/Output Table																																				
Set-Clear (J-K) Flip-Flop		A bistable device with two inputs and two outputs (either or both outputs may be used) The outputs change state in response to the states at the inputs The outputs are complementary (i.e., when one output is HI the other is LO)	<table border="1"> <thead> <tr> <th colspan="2">Input</th> <th colspan="2">Output</th> </tr> <tr> <th>A</th> <th>B</th> <th>X</th> <th>X</th> </tr> </thead> <tbody> <tr> <td>LO</td> <td>LO</td> <td colspan="2">No change</td> </tr> <tr> <td>LO</td> <td>HI</td> <td>LO</td> <td>HI</td> </tr> <tr> <td>HI</td> <td>LO</td> <td>HI</td> <td>LO</td> </tr> <tr> <td>HI</td> <td>HI</td> <td colspan="2">Changes state</td> </tr> </tbody> </table>	Input		Output		A	B	X	X	LO	LO	No change		LO	HI	LO	HI	HI	LO	HI	LO	HI	HI	Changes state													
Input		Output																																					
A	B	X	X																																				
LO	LO	No change																																					
LO	HI	LO	HI																																				
HI	LO	HI	LO																																				
HI	HI	Changes state																																					
D (data) Type Flip-Flop		A bistable device with two inputs and two outputs (either or both outputs may be used) When triggered the state of the "1" output changes to the state at the data (D) input prior to the trigger The outputs are complementary (i.e., when one output is HI the other is LO) The edge symbol on the trigger (T) input may be of either polarity, depending on the device	<table border="1"> <thead> <tr> <th>Input</th> <th colspan="2">Output</th> </tr> <tr> <th>A</th> <th>X</th> <th>X</th> </tr> </thead> <tbody> <tr> <td>LO</td> <td>LO</td> <td>HI</td> </tr> <tr> <td>HI</td> <td>HI</td> <td>LO</td> </tr> </tbody> </table> <p>Output conditions shown after trigger pulse</p>	Input	Output		A	X	X	LO	LO	HI	HI	HI	LO																								
Input	Output																																						
A	X	X																																					
LO	LO	HI																																					
HI	HI	LO																																					
Triggered Set-Clear (J-K) Flip-Flop		A bistable device with three or more inputs and two outputs (either or both outputs may be used) When triggered, the outputs change state in response to the states at the inputs prior to the trigger The outputs are complementary (i.e., when one output is HI the other is LO) The edge symbol on the trigger (T) input may be of either polarity depending on the device	<table border="1"> <thead> <tr> <th colspan="2">Input</th> <th colspan="2">Output</th> </tr> <tr> <th>A</th> <th>B</th> <th>X</th> <th>X</th> </tr> </thead> <tbody> <tr> <td>LO</td> <td>LO</td> <td colspan="2">No change</td> </tr> <tr> <td>LO</td> <td>HI</td> <td>LO</td> <td>HI</td> </tr> <tr> <td>HI</td> <td>LO</td> <td>HI</td> <td>LO</td> </tr> <tr> <td>HI</td> <td>HI</td> <td colspan="2">Changes state</td> </tr> </tbody> </table> <p>Output conditions shown after trigger pulse</p>	Input		Output		A	B	X	X	LO	LO	No change		LO	HI	LO	HI	HI	LO	HI	LO	HI	HI	Changes state													
Input		Output																																					
A	B	X	X																																				
LO	LO	No change																																					
LO	HI	LO	HI																																				
HI	LO	HI	LO																																				
HI	HI	Changes state																																					
Flip-Flop with Direct Inputs (may be applied to all triggered flip-flops)		For devices with direct-set (S_D) or direct-clear (C_D) inputs, the indicated state at either of these inputs over-rides all other inputs (including trigger) to set the outputs to the states shown in the input/output table	<table border="1"> <thead> <tr> <th colspan="4">Input</th> <th colspan="2">Output</th> </tr> <tr> <th>A</th> <th>B</th> <th>C</th> <th>D</th> <th>X</th> <th>X</th> </tr> </thead> <tbody> <tr> <td>1</td> <td>1</td> <td>LO</td> <td>LO</td> <td colspan="2">No change¹</td> </tr> <tr> <td>Φ</td> <td>Φ</td> <td>LO</td> <td>HI</td> <td>LO</td> <td>HI</td> </tr> <tr> <td>Φ</td> <td>Φ</td> <td>HI</td> <td>LO</td> <td>HI</td> <td>LO</td> </tr> <tr> <td>Φ</td> <td>Φ</td> <td>HI</td> <td>HI</td> <td colspan="2">Undefined</td> </tr> </tbody> </table> <p>Φ = Has no effect in this case ¹Output state determined by conditions at triggered inputs</p>	Input				Output		A	B	C	D	X	X	1	1	LO	LO	No change ¹		Φ	Φ	LO	HI	LO	HI	Φ	Φ	HI	LO	HI	LO	Φ	Φ	HI	HI	Undefined	
Input				Output																																			
A	B	C	D	X	X																																		
1	1	LO	LO	No change ¹																																			
Φ	Φ	LO	HI	LO	HI																																		
Φ	Φ	HI	LO	HI	LO																																		
Φ	Φ	HI	HI	Undefined																																			

NOTE

Logic symbols used on the diagrams depict the logic function and may differ from the manufacturer's data.

LOGIC POLARITY

All logic functions are described using the positive logic. Positive logic is a system of notation where the more positive of two levels (HI) is called the true or I-state; the more negative level (LO) is called the false or O-state. The HI-LO method of notation is used in this logic description. The specific voltages which constitute a HI or LO state vary between individual devices.

INPUT/OUTPUT TABLES

Input/output (truth) tables are used in conjunction with the logic diagrams to show the input combinations which are of importance to a particular function, along with the resultant output conditions. This table may be given either for an individual device or for a complete logic stage. For examples of input/output tables for individual devices, see Table 3-1.

NON-DIGITAL DEVICES

Not all of the integrated circuits in this instrument are digital logic devices. The function of non-digital devices will be described individually.

BLOCK DIAGRAM

All major circuits and basic interconnections of the 7623A are represented in the block diagram, Figure 3-1. The numbered diamond in each block refers to the respective schematic diagram for that circuit, located at the rear of this manual.

The Main Interface, block 1, provides the interconnections between the plug-in compartments and the various circuits and functions of the instrument.

Signals from both vertical plug-in compartments are applied to the Vertical Interface circuit. This circuit determines whether the signal from the left or right plug-in unit is displayed. The selected vertical signal is then amplified by the Vertical Amplifier circuit to drive the vertical deflection plates of the CRT. The Vertical Amplifier also accepts the Y-Readout signal from the Readout System to produce the vertical portion of the alpha-numeric readout display.

Signals from the horizontal plug-in compartment are applied to the Horizontal Amplifier circuit where they are amplified to provide horizontal deflection of the CRT electron beam. The Horizontal Amplifier circuit also accepts the X-Readout signal from the Readout System to produce the horizontal portion of the readout display.

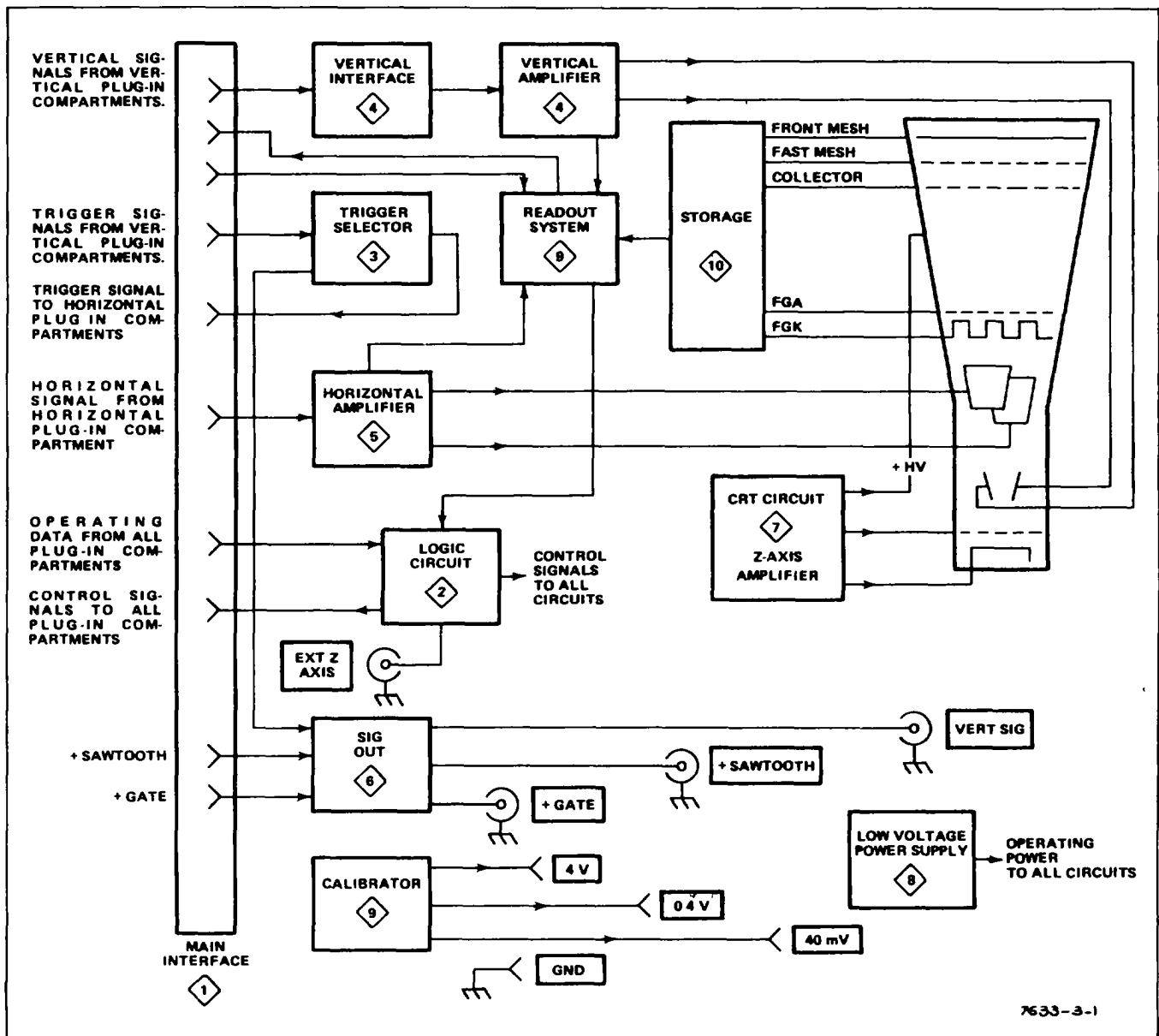

Figure 3-1. Block diagram 7623A.

The Logic Circuit develops control signals for use in other circuits within the instrument and the associated plug-in units. These control signals determine the correct operation of the instrument in relation to the plug-in installed or selected, the plug-in control settings, and the 7623A control settings.

Trigger signals from the vertical plug-in units are connected to the Trigger Selector circuit to be used for internal triggering. This circuit selects the trigger signals to be applied to the plug-in unit in the horizontal compartment. This signal is also amplified by the Trigger Selector circuit and routed to the Output Signals circuit to become the Vertical Signal Output.

Theory of Operation-7623A/R7623A Service

In addition to the Vertical Signal Output mentioned above, the Output Signals circuit also provides a + SAWTOOTH OUT signal and a + GATE OUT signal-both derived from the horizontal plug-in unit and accessible through rear panel connectors.

The crt circuit produces the voltages and contains the controls necessary for operation of the cathode ray tube. This includes the Z-Axis Amplifier, which provides the drive signal to control the intensity of the crt display.

The Low-Voltage Power Supply provides the power necessary for operation of the entire instrument and associated plug-in units.

The Storage Circuit produces the timing signals and voltages required to operate the storage functions of the crt.

The Readout System provides an alpha-numeric display for information encoded by the plug-in units. This display is presented on the crt on a timeshared basis with the primary analog waveform display.

(A)

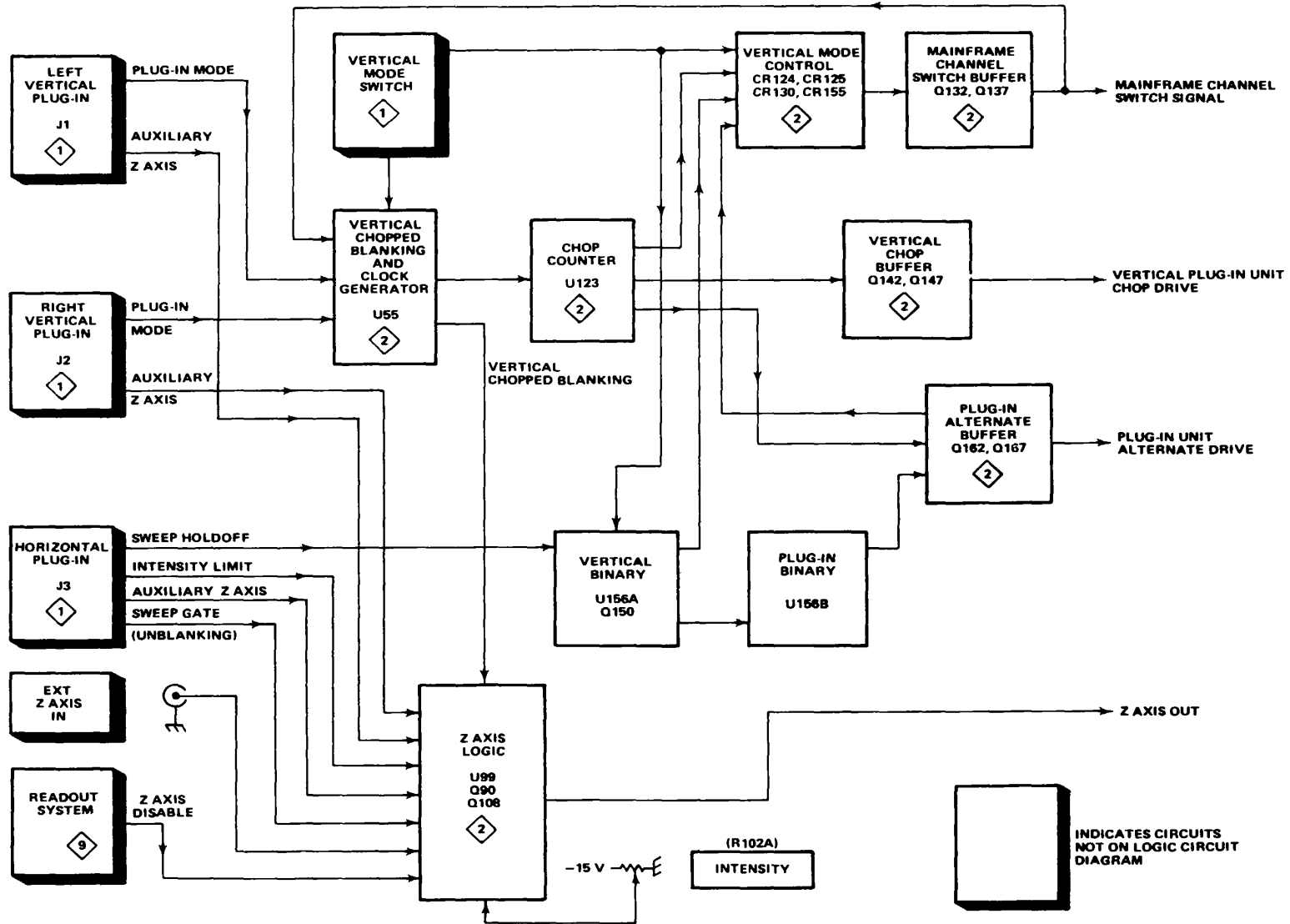

Figure 3-2. Logic block diagram.

THEORY OF OPERATION

The following circuit descriptions are referenced to their respective diagrams by the numbered diamonds accompanying each main heading

MAIN INTERFACE <1>

Diagram 1 shows the plug-in interface and the interconnections between the plug-in compartments, circuit boards, etc., of this instrument. This diagram also contains the TRIG SOURCE and VERT MODE switching and the Camera Power Connector.

LOGIC CIRCUIT <2>

The Logic Circuit develops control signals for use in other circuits within this instrument and in the associated plug-in units. These signals determine the correct instrument operation in relation to the plug-in installed and selected, the plug-in control settings, and the 7623A control settings. Figure 3-2 is a simplified block diagram of the Logic Circuit.

Z-AXIS LOGIC

The Z-Axis Logic stage produces an output current which sets the intensity of the display on the CRT. The Z-Axis output current is determined by the setting of the front-panel INTENSITY control, an external signal from the rear panel EXT Z-AXIS input connector, or signals from the plug-in compartments. The Vertical Chopped Blanking from U55 is applied to this stage to blank the CRT display during vertical trace switching. The Intensity Limit input from the horizontal plug-in compartment operates at slow sweep rates to provide protection for the CRT phosphor.

The Z-Axis Logic stage consists of transistor Q108, dual-transistor 090 and integrated circuit U99, which is a five-transistor array. A simplified schematic of the Z-Axis Logic stage is shown in Figure 3-3.

Transistor U99C is connected in the common-base configuration to provide the output for this stage. The collector load for U99C is provided by the Z-Axis Amplifier in the CRT Circuit. Transistors U99D and U99E provide a current-setting action for this stage. The collector current of U99D, represented by I_t , is the maximum amount of current that can flow in the circuit. The amount of this current is determined by both the Intensity Limit and Vertical Chopped Blanking. When both of these inputs are HI the collector current of U99D, I_t , is maximum. This maximum level of I_t is determined by current I_1 in the base circuit of U99D established by networks R76-R77 and R62-R63 into R110 and the collector of U99E. During Vertical Chopped Blanking, the respective input level goes LO. This reduces so the collector current of U99D, I_t , drops to blank the CRT display during vertical trace switching.

The collector current of U99C, I_s , is the difference between I_t and I_2 . When the Sweep Gate level at the base of U99A is LO (no sweep in progress) U99A is off. I_2 is at its maximum level so that I_s is I_2 minimum to provide minimum intensity of the display (I_s is always = $I_t - I_2$). During sweep time, the Sweep Gate level is HI and turns U99A on by the current established by INTENSITY control R102. As the

(A)

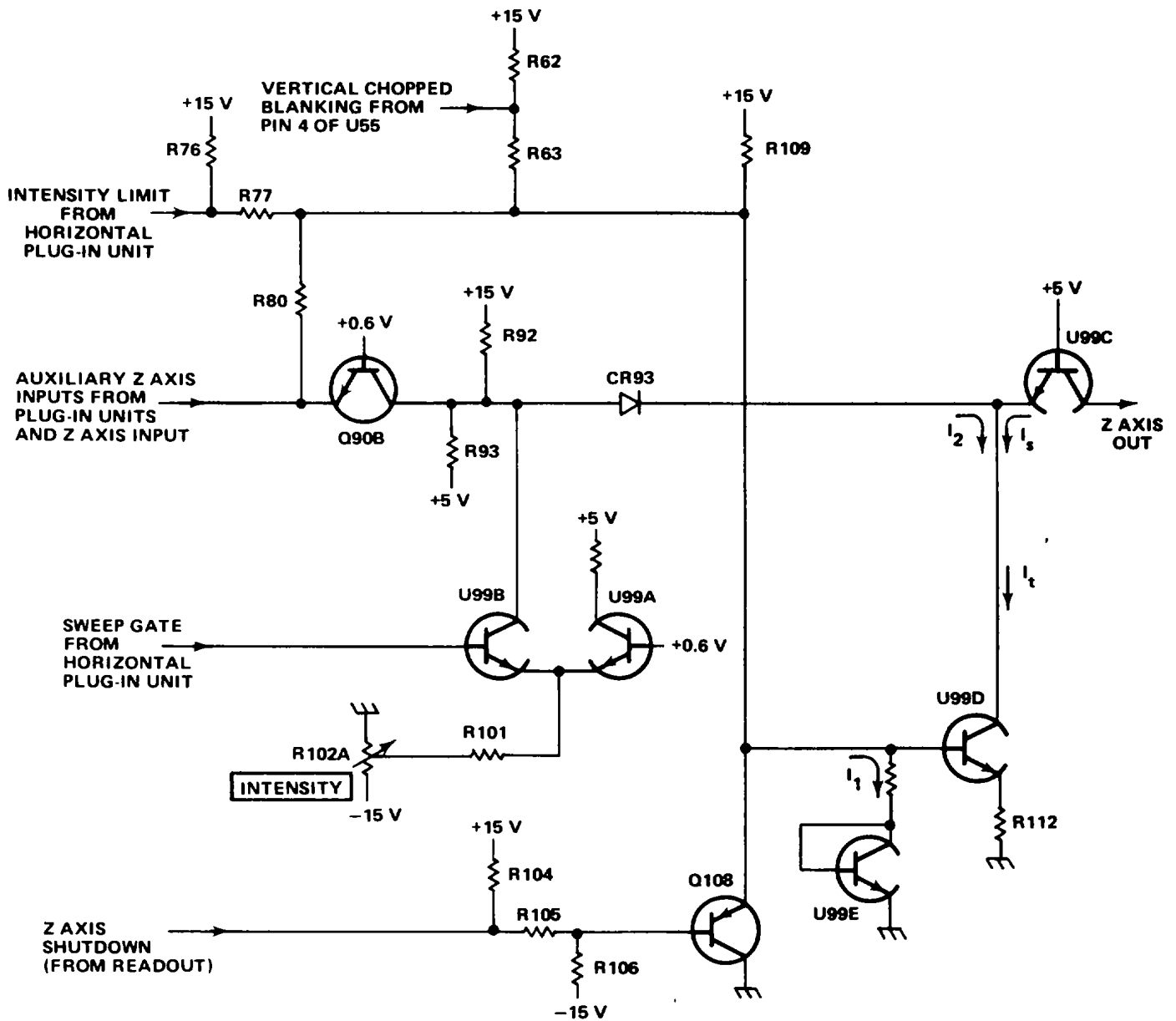

Figure 3-3. Z-Axis Logic block diagram.

INTENSITY control is turned toward maximum, the level of I_2 decreases. This allows I_3 to increase to produce a brighter display. The Auxiliary Z-Axis Inputs from the plug-in compartments and the Intensity modulating signal from the EXT Z-AXIS input connector are connected to the emitter of Q90B. These signals modulate the level of I_2 to, in turn, modulate the intensity of the display.

Through R77 and R78, this causes equal reductions in currents I_1 and I_2 except, because of diode CR93, I_2 cannot be less than zero. This limiting action does not change I_3 except to limit its maximum value to this lower I_1 value.

(A)

When the time-base unit is set to a sweep rate which requires intensity limiting, the Intensity Limit Input goes to ground level in the plug-in unit. Through R77 and R78, this causes equal reductions in currents I_1 and I_2 except, because of diode CR93, I_2 cannot be less than zero. This limiting action does not change I_s except to limit its maximum value to this lower I_1 value.

When readout information is to be displayed on the CRT, the Z-Axis shutdown goes LO. This forward biases Q108, and it saturates, shunting I_1 to ground. This reduces the output current to zero during the readout time.

CLOCK GENERATOR

One half of integrated circuit U55 along with the external components shown in Figure 3-4A make up the Clock Generator stage. R1, Q1, Q2, and Q3 represent an equivalent circuit contained within U55A. This circuit, along with discrete components C59, R56, R57, and R59 comprise a two-megahertz, free-running oscillator to provide a timing signal (clock) for mainframe vertical and plug-in chopping.

The stage operates as follows: Assume that Q2 is conducting and Q1 is off. The collector current of Q2 produces a voltage drop across R1 which holds Q1 off. This negative level at the collector of Q2 is also connected to pin 14 through Q3 (see waveforms in Fig.3-4B at time T_0). Since there is no current through Q1, C59 begins to charge towards -15 volts through R56-R57. The emitter of Q1 goes negative as C59

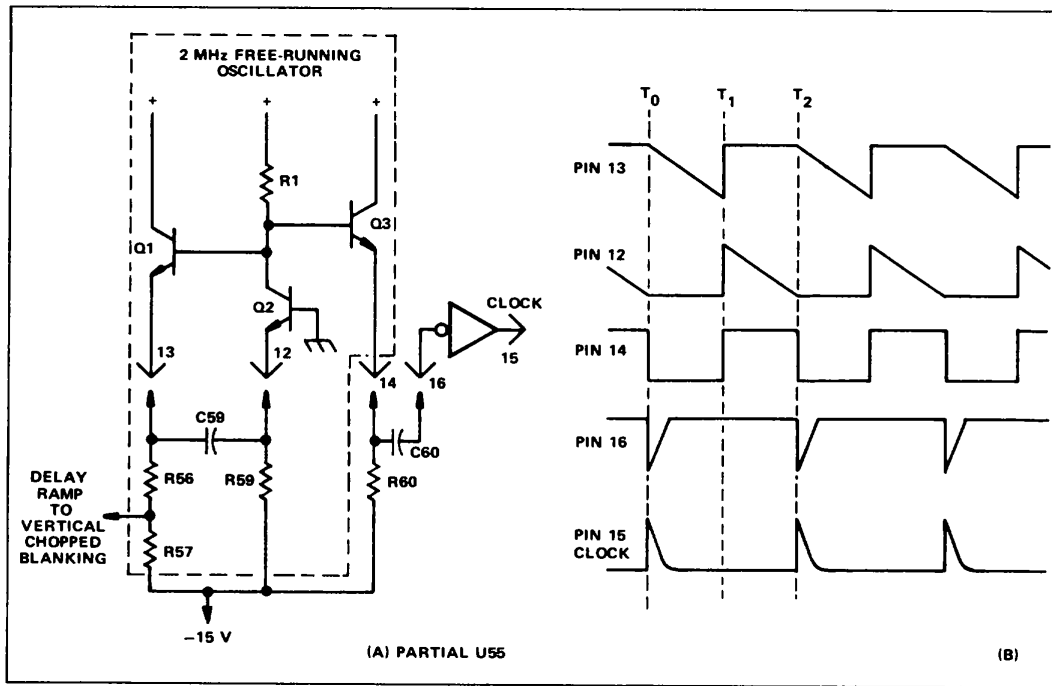

Figure 3-4. (A) Clock Generator stage of U55A. (B) Idealized waveforms from Clock Generator stage.

(A)

Theory of Operation-7623A/R7623A Service

charges until it reaches a level about 0.6 volt more negative than the level at its base. Then, Q1 is forward biased and its emitter rapidly rises positive. Since C59 cannot change its charge instantaneously, the sudden change in voltage at the emitter of Q1 pulls the emitter of Q2 positive also, to reverse-bias it. With Q2 reverse biased, its collector rises positive to produce a positive output level at pin 14 (see time T_1 on the waveforms).

Now, conditions are reversed. Since Q2 is reverse biased, there is no current through it. Therefore, C59 can begin to discharge through R59. The emitter level of Q2 follows the discharge of C59 until it reaches a level about 0.6 volt more negative than its base. Then Q2 is forward biased and its collector drops negative to reverse-bias Q1. The level at pin 14 drops negative also, to complete the cycle.

Two outputs are provided from this oscillator. The Delay Ramp signal from the junction of R56-R57 is connected to the Vertical Chopped Blanking stage. This signal has the same waveshape as shown by the waveform at pin 13, with its slope determined by the divider ratio between R56-R57. A square-wave output is provided at pin 14. The frequency of this square wave is determined by the RC relationship between C59 and R56, R57, and R59. The duty cycle is determined by the ratio of R56-R57 to R59.

The square wave at pin 14 is connected to pin 16 through C60. C60, along with the internal resistance of U55A, differentiates the square wave from pin 14, to produce a negative-going pulse coincident with the falling edge of the square wave (positive-going pulse coincident with rising edge has no effect on circuit operation). This negative-going pulse is connected to pin 15 through an inverter-shaper which is also part of U55A. The output at pin 15 is a positive-going Clock pulse at a repetition rate of about two megahertz.

VERTICAL CHOPPED BLANKING

The Vertical Chopped Blanking stage is made up of the remaining half of integrated circuit U55B, Fig 3-5A. This stage determines if Vertical Chopped Blanking pulses are required, based upon the operating mode of the vertical system or the plug-in units (dual trace units only). Vertical Chopped Blanking pulses are produced if (1) VERT MODE switch is set to CHOP, (2) dual-trace vertical unit is operating in the chopped mode and that unit is being displayed, (3) dual-trace vertical unit is operating in the chopped mode with the VERT MODE switch set to ADD. The repetition rate of the negative-going Vertical Chopped Blanking pulse output at pin 4 is always two megahertz as determined by the Clock Generator stage.

The Delay Ramp signal from the Clock Generator stage determines the repetition rate and pulse width of the Vertical Chopped Blanking pulses. The Delay Ramp applied to pin 10 starts to go negative from a level of about +1.1 volts coincident with the leading edge of the Clock pulse (see waveforms in Fig 3-5B). This results in a HI quiescent condition for the Vertical Chopped Blanking pulse. The slope of the negative-going Delay Ramp is determined by the Clock Generator stage. As it reaches a level slightly negative from ground, the Vertical Chopped Blanking pulse output level changes to the LO state. This signal remains LO until the Delay Ramp goes HI again. Notice the delay between the leading edge of the Clock pulse generated by U55A and the leading edge of the Vertical Chopped Blanking pulse would not coincide with the switching between the displayed traces. The duty cycle of the square wave produced in the Clock Generator stage determines the pulse width of the Vertical Chopped Blanking pulses (see Clock Generator discussion for more information).

(A)

Whenever this instrument is turned on, the Vertical Chopped Blanking pulses are being produced at a two-megahertz rate. However, these pulses are available as an output at pin 4 only when the remaining inputs to U55B are at the correct levels. The following discussions give the operating conditions which produce Vertical Chopped Blanking pulses to blank the crt during vertical trace switching. Figure 3-5A identifies the functions of the pins of U55B.

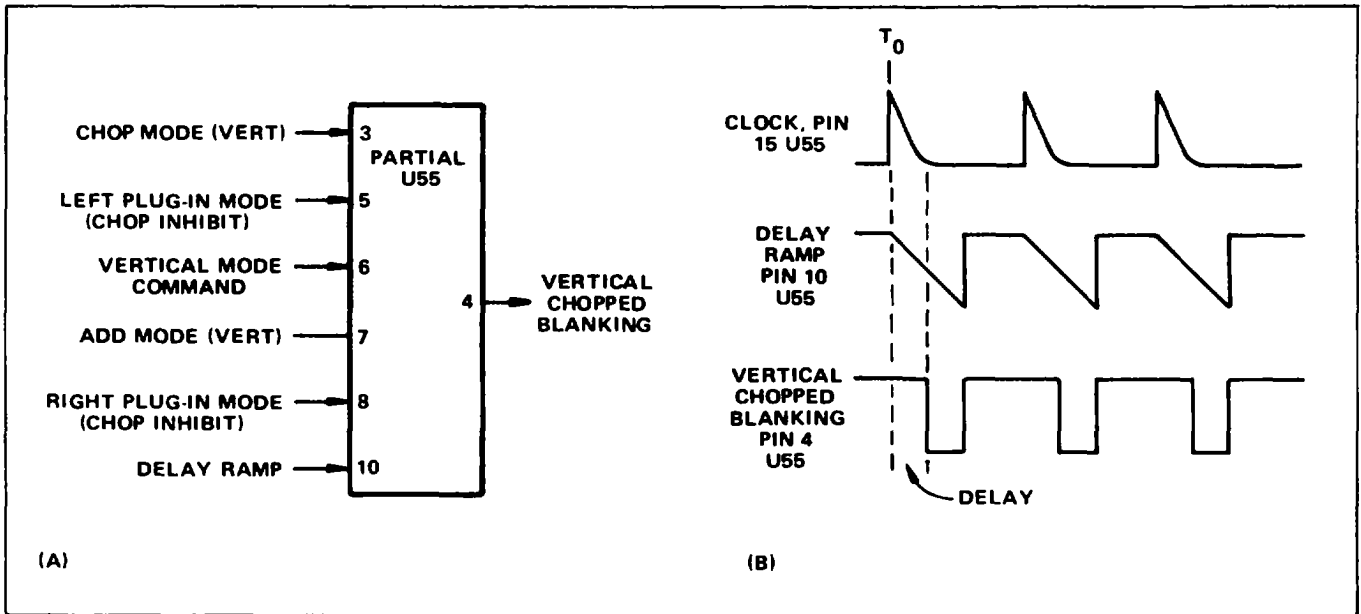

Figure 3-5. (A) Input and output pins for Vertical Chopped Blanking stag.(B) Idealized waveforms for Vertical Chopped Blanking stage.

(A)

Theory of Operation-7623A/R7623A Service

CHOP VERTICAL MODE

When the VERT MODE switch is set to CHOP, Vertical Chopped Blanking pulses are available at pin 4 at all times. The input conditions necessary are:

PIN 3 HI - VERT MODE switch set to CHOP.

Pin 7 LO - VERT MODE switch set to any position except ADD.

Pin 10 LO - Delay Ramp more negative than about 0 volts.

LEFT VERTICAL UNIT SET FOR CHOPPED OPERATION

If the Left Vertical unit is set for chopped operation, the setting of the VERT MODE switch determines whether the Vertical Chopped Blanking pulses are available. If the VERT MODE switch is set to the CHOP position, conditions are described above. Operation in the ADD position of the VERT MODE switch is given later. For the LEFT position of the VERT MODE switch, or when the left vertical unit is to be displayed in the ALT mode, Vertical Chopped Blanking pulses are available at all times (two-megahertz rate). The Input conditions are.

Pin 3 LO - VERT MODE switch set to any position except CHOP.

Pin 5 LO - Left vertical unit set to chopped mode.

Pin 6 LO - Left vertical unit to be displayed (Vertical Mode Command LO).

Pin 7 LO - VERT MODE switch set to any position except ADD.

Pin 10 LO - Delay Ramp more negative than about 0 volts.

Notice that the Vertical Mode Command at pin 6 must be LO for output pulses to be available at pin 4. This means that when the VERT MODE switch is set to ALT, Vertical Chopped Blanking pulses are produced only during the time that the left vertical unit is to be displayed (unless right vertical unit is also set for chopped operation).

RIGHT VERTICAL UNIT SET FOR CHOPPED OPERATION

If the right vertical unit is set for chopped mode, operation is the same as described previously for the left vertical unit except that Vertical Chopped Blanking pulses are produced when the VERT MODE switch is set to RIGHT or when the Vertical Mode Command is HI in the ALT mode. The input conditions are:

Pin 3 LO - VERT MODE switch set to any position except CHOP.

Theory of Operation-7623A/R7623A Service

Pin 6 HI - Right vertical unit to be displayed (Vertical Mode Command HI).

Pin 7 LO - VERT MODE switch set to any position except ADD.

Pin 8 LO - Right vertical unit set to chopped mode.

Pin 10 LO - Delay Ramp more negative than about 0 volts.

ADD VERTICAL MODE

When the VERT MODE switch is in the ADD position and either or both of the vertical units are operating in the chopped mode, Vertical Chopped Blanking pulses must be available to block out the transition between traces of the vertical units. The input conditions are:

Pin 3 LO - VERT MODE switch set to any position except CHOP.

Pin 5 LO - Left vertical unit set to chopped mode (can be HI if pin 8 is LO).

Pin 7 HI - VERT MODE switch set to ADD.

Pin 8 LO - Right vertical unit set to chopped mode (can be HI if pin 5 is LO).

Pin 10 LO - Delay Ramp more negative than about 0 volt.

Fig.3-6A shows a logic diagram of the Vertical Chopped Blanking stage. Notice the comparator block on this diagram (one input connected to pin 10).The output of this comparator is determined by the relationship between the levels at its inputs. If pin 10 is more positive (HI) than the grounded input, the output is HI also; if it is more negative (LO), the output is LO. An input/output table for this stage is given in Fig.3-6.

CHOP COUNTER

The Chop Counter stage produces the Mainframe Chop Signal and the Vertical Plug-In Chop Signal. The Clock pulse produced by the Clock Generator stage provides the timing signal for this stage. A logic diagram of the Chop Counter, identifying the inputs and outputs, is shown in Fig.3-7.

The Chop Counter stage consists of integrated circuit U123, a dual D-type flip-flop with direct-set, direct-clear inputs (see Table 3-1 for operation of D-type flip-flop).As connected in this circuit, these D-type flip-flops operate as triggered (toggle) flip-flops.

The two-megahertz clock pulses from the Clock Generator stage are connected to the trigger (T) input of U123B.As connected, U123B changes output states with each positive-going Clock pulse, and the signal as its '1'output is a square wave which switches between the HI and LO levels at a one-megahertz

(A)

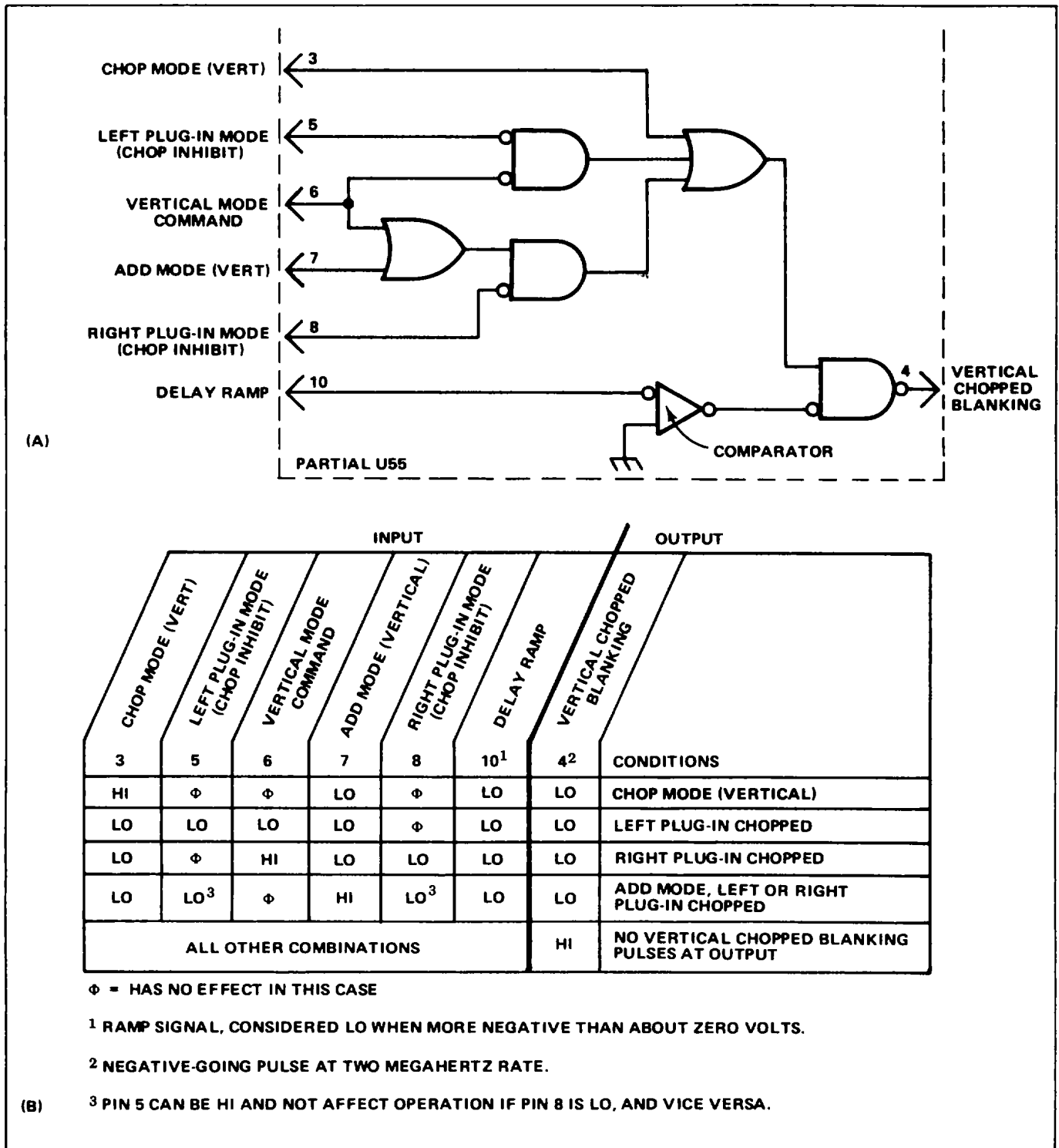

Figure 3-6. (A) Logic diagram for Vertical Chopped Blanking stage. (B) Table of input/output combinations for Vertical Chopped Blanking stage.

rate This signal is connected to the Vertical Mode Control stage to provide the Vertical Mainframe Chop Signal. It is also connected to the trigger Input of U123A. U123A also changes output states with each positive-going pulse at its trigger input to produce a 500 kilohertz square wave at its '1' output. The output from U123A provides the Vertical Plug-In Chop Signal to the Plug-In Chop Buffer stage. Idealized waveforms showing the timing relationship between the input and output signals for this stage are shown in Fig. 3-8.

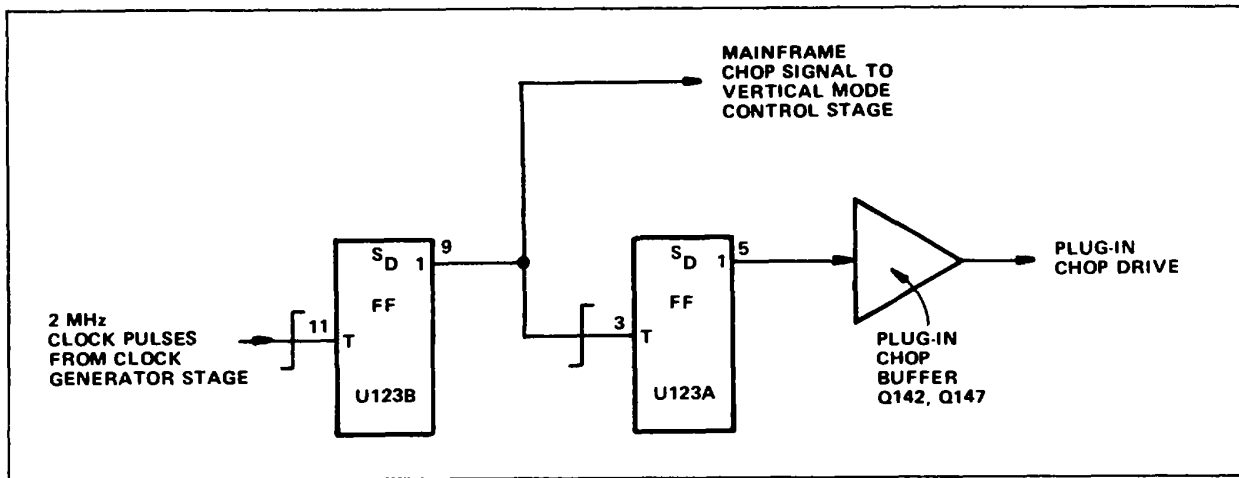

Figure 3-7. Detailed logic diagram of Chop Counter stage.

VERTICAL MODE CONTROL

The Vertical Mode Control stage is made up of discrete components CR1 24-CR125, CR 126, CR130- CR155, CR172, and buffer amplifier Q132-Q137. These components develop the Mainframe Vertical Mode Command which is connected to the Main Interface circuit (vertical plug-in compartments and trigger selection circuitry) and the Vertical Interface circuit to indicate which vertical unit is to be displayed. When this output level is HI, the right vertical unit is displayed and when it is LO, the left vertical unit is displayed.

The VERT MODE switch located on diagram 1 provides control levels for this stage. This switch provides a HI level on only one of four output lines to indicate the selected vertical mode, the remaining lines are LO. The fifth mode, LEFT, is indicated when all four output lines are LO. Operation of this stage in all positions of the VERT MODE switch is as follows:

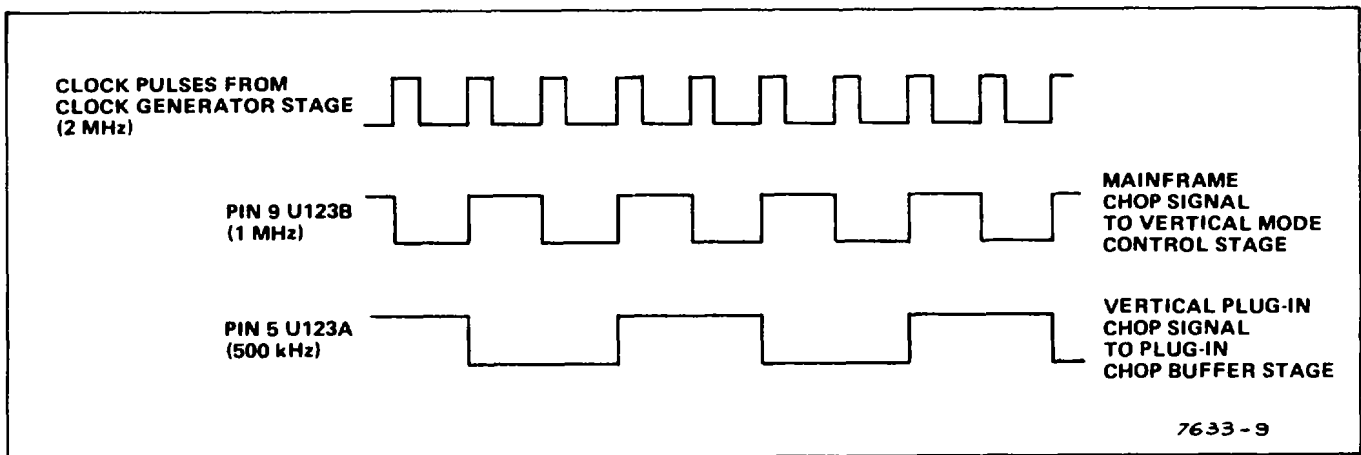

Figure 3-8. Idealized input and output waveforms for Chop Counter stage.

(A)

Theory of Operation-7623A/R7623A Service

RIGHT

When the VERT MODE switch is set to RIGHT, a HI level is connected to the Buffer Amplifier through R 126 and CR126. The LO level at the anodes of diodes CR125 and CR130 holds them reverse biased. The resultant Vertical Mode Command output from the Vertical Mode Buffer Amplifier is a HI level to indicate that the right vertical unit is to be displayed.

CHOP

In the CHOP position of the VERT MODE switch, a HI level is applied to the anodes of diodes CR124-CR125 through R125. Both diodes are forward biased so the Vertical Chop Signal from pin 9 of U1 23B can pass to the emitter of Q132. This signal switches between the HI and LO levels at a one-megahertz rate and it produces a corresponding Mainframe Vertical Mode Command output at the emitter of Q137. When this output is HI, the right vertical unit is displayed and when it switches to LO, the left vertical unit is displayed.

ALT

In the ALT mode, the VERT MODE switch applies a HI level to the anodes of diodes CR130-CR155 through R130. These diodes are forward biased so the Display Right Command from pin 5 of U156A can pass to the emitter of Q132 to determine the Mainframe Vertical Mode Command level. The Display Right Command switches between its HI and LO levels at a rate determined by the Vertical Binary stage.

ADD AND LEFT

The control levels in the ADD and LEFT positions of the VERT MODE switch are not connected to this stage. However, since only the line corresponding to the selected vertical mode can be HI, the RIGHT, CHOP, and ALT lines must remain at their LO level when either LEFT or ADD are selected. Therefore, the emitter of Q132 remains LO to produce a LO Mainframe Vertical Mode Control output level. Final control of LEFT or ADD mode is made by the Vertical Interface circuit.

A logic diagram of the Vertical Mode Control stage is shown in Fig.3-9. The discrete components which make up each logic function are identified. The gate connected to the Input of the Vertical Mode Buffer Amplifier is a phantom-OR gate. A phantom-OR gate performs the OR logic function merely by interconnection of the three inputs.

VERTICAL BINARY

The Vertical Binary stage consists of integrated circuit U156A and transistor Q150. U156A is a D-type flip-flop with direct-set and direct-clear inputs (see Table 3-1 for operating details). The connection between the "O" output and the data (D) input enables this flip-flop to operate in the triggered mode. A logic diagram of the Vertical Binary stage is shown in Fig 3-10.

(A)

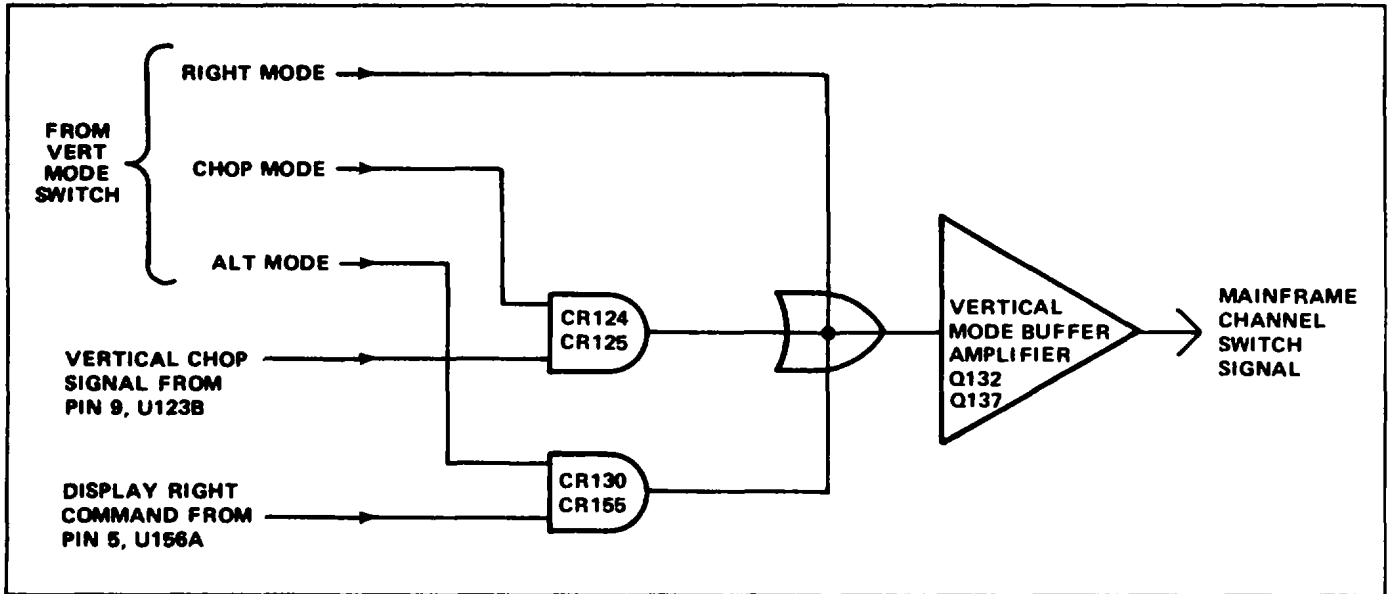

Figure 3-9. Logic diagram of Vertical Mode Control and Vertical Mod Buffer amplifier stages.

The operation of the Vertical Binary stage is controlled by the level of the ALT Mode line from the VERT MODE switch. When this switch is set to ALT, a HI level is connected to the emitter of Q150 through R152. This HI level disables Q150 so its collector remains HI. As a result, Q150 has no effect upon operation of the Vertical Binary stage and the direct-clear input of U156A remains HI so it does not affect the operation of U156A. Therefore, U156A operates as a basic triggered flip-flop which changes output states with each positive-going Sweep Holdoff pulse at the trigger (T) input. The Sweep Holdoff pulse goes positive at the end of each sweep. The signal at the '1' output of U156A switches between the HI and LO level at one-half the rate of the Sweep Holdoff signal from the horizontal plug-in unit. Fig. 3-11 shows the time relationship between the input and output signals for this stage, and gives the resultant display with each signal combination.

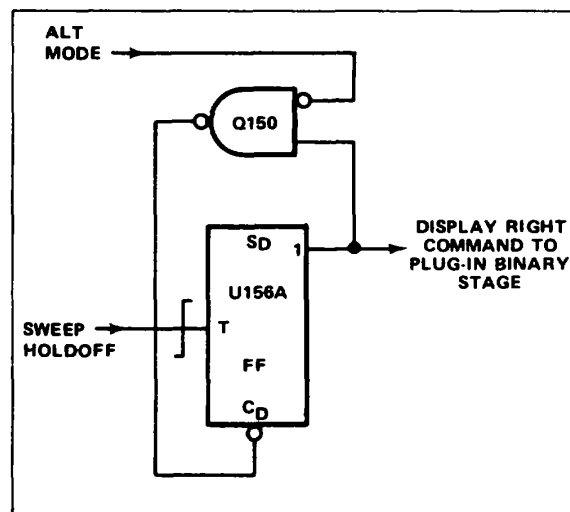

Figure 3-10. Logic diagram of Vertical Binary stage.

(A)

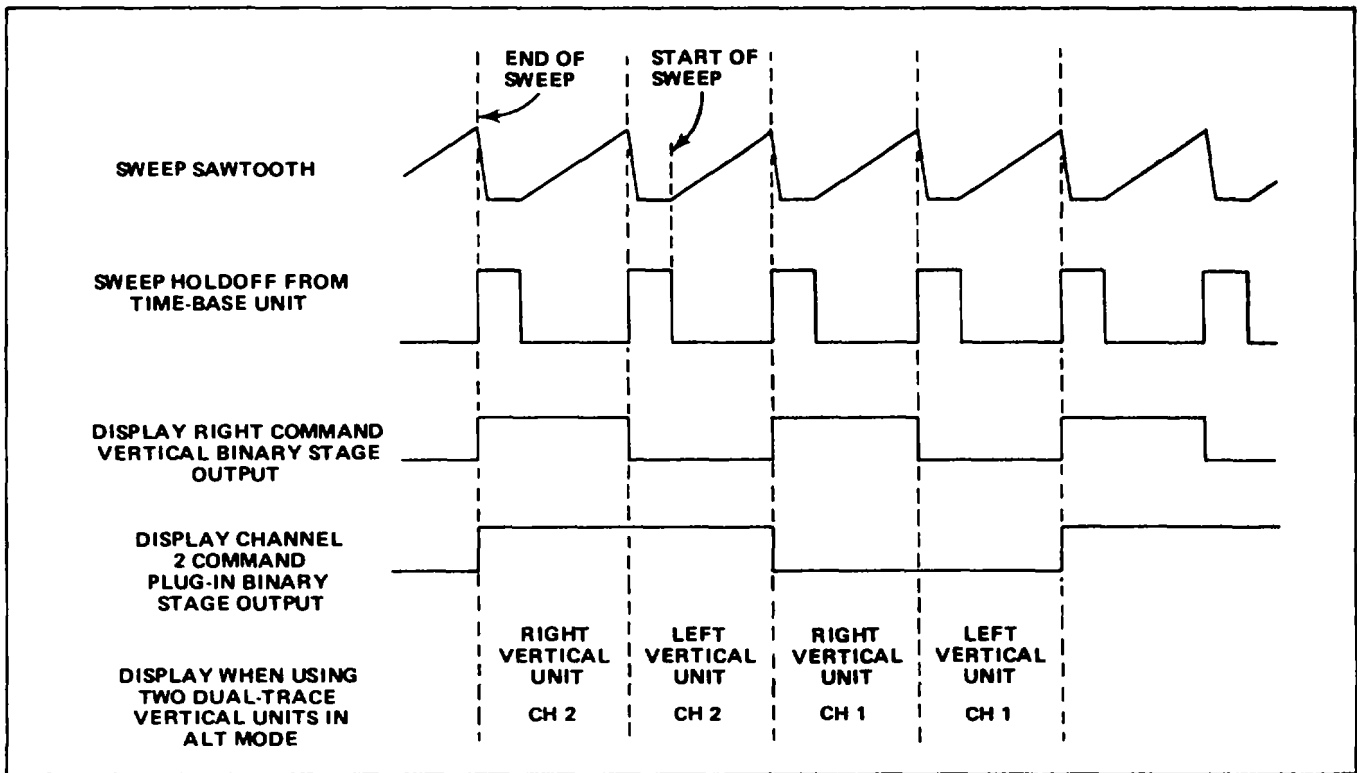

Figure 3-11. Idealized waveforms showing relationship between input and output waveforms for Vertical Binary and Plug-In Binary stages when operating in ALT mode.

For any other position, the emitter of Q150 is pulled LO by the ALT Mode command from the VERT MODE switch. This enables Q150, but it does not change output state unless the level at the '1' output of U156A is HI. Quiescently, the output of Q150 is HI. Therefore, when the positive-going Sweep Hold-off pulse is received at the end of the sweep, the '1' output of U156A goes HI. This activates Q150 and its output goes LO to provide a direct-clear reset to U156A. The '1' output of U156A is reset to its LO level, and Q150 is again disabled so its output returns to the HI level. The stage is now ready for the next positive-going Sweep Hold-off pulse. The action is the same with each pulse, so the signal at the output of this stage is at the same repetition rate as the Sweep Hold-off input. Therefore, this stage is now operating as a divide-by-one counter rather than a divide-by-two counter as described previously. The output under this condition is used only by the Plug-In Binary stage.

Since the Vertical Binary stage can change output states only at the end of each sweep, there will be no Alternate Drive signal for either the mainframe or vertical plug-in units if a sweep is not being produced by the horizontal plug-in unit.

PLUG-IN BINARY

The Plug-In Binary stage consists of U156B, which is connected as a triggered flip-flop with direct-set input. The trigger input for this stage is the Display Right Command from the Vertical Binary stage. When the VERT MODE switch is set to ALT, the repetition rate of the Display Channel 2 Command output of this stage is one-fourth of the Sweep Hold-off input (see waveforms in Fig.3-11). For any position of the VERT MODE switch except ALT, the repetition rate of the output signal from this stage is one-half of the Sweep Hold-off input. A logic diagram of the Plug-In Binary stage is shown in Fig.3-12.

(A)

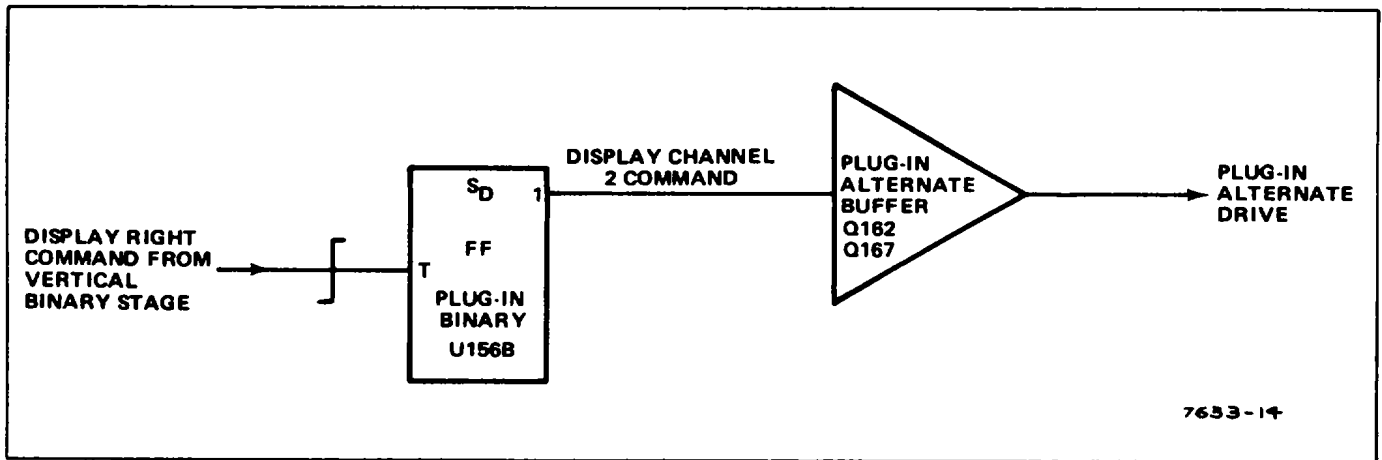

Figure 3-12. Logic diagram of Plug-In Binary and Plug-In Alternate Buffer stage.

OUTPUT BUFFERS

The output switching commands from the Logic circuit are provided through buffer stages 0142, 0137, Q142-Q147, 0162-Q167, and Q182-Q187. Each of these stages includes a common-base input transistor to provide a low-impedance load for the associated driving stages. The output transistor is connected as an emitter-follower to provide isolation between the Logic circuit and other circuits within this instrument or the plug-in units.

TRIGGER SELECTOR <3>

The Trigger source switch determines which vertical signal is connected to the time-base unit, and which vertical signal, that is provided at VERT SIG/OUT connector on the rear panel. Fig 3-13 shows a detailed block diagram of the Trigger Selector circuit, along with a simplified diagram of all the circuitry involved in selection of the trigger source. A schematic of the Trigger Selector circuit is shown on diagram 3 at the rear of this manual.

TRIGGER MODE AND ADD SIGNALS

GENERAL

The circuitry shown on the left side of the simplified diagram in Fig.3-13 determines the operation of the Trigger Channel Switch stage. TRIG SOURCE switch S1010 controls Trigger Channel Switch U324. When the TRIG SOURCE switch is set to the VERT MODE position, the setting of the VERT MODE switch determines the trigger selection. In the LEFT or RIGHT positions, the trigger signal is obtained from the indicated vertical unit. The following discussions give detailed operation in each position of the TRIG SOURCE switch.

VERT MODE

In the VERT MODE position of the TRIG SOURCE switch, the setting of the VERT MODE switch determines the operation of the Trigger Channel Switch stage. In the LEFT position of the VERT MODE switch, the base of Q314 is connected to ground through the ALT and RIGHT sections of S1021, CR1021 and CR1026, and S1011. This holds Q314 reverse biased to provide a LO level to pin 4 of U324 (see Fig.3-14).

(A)

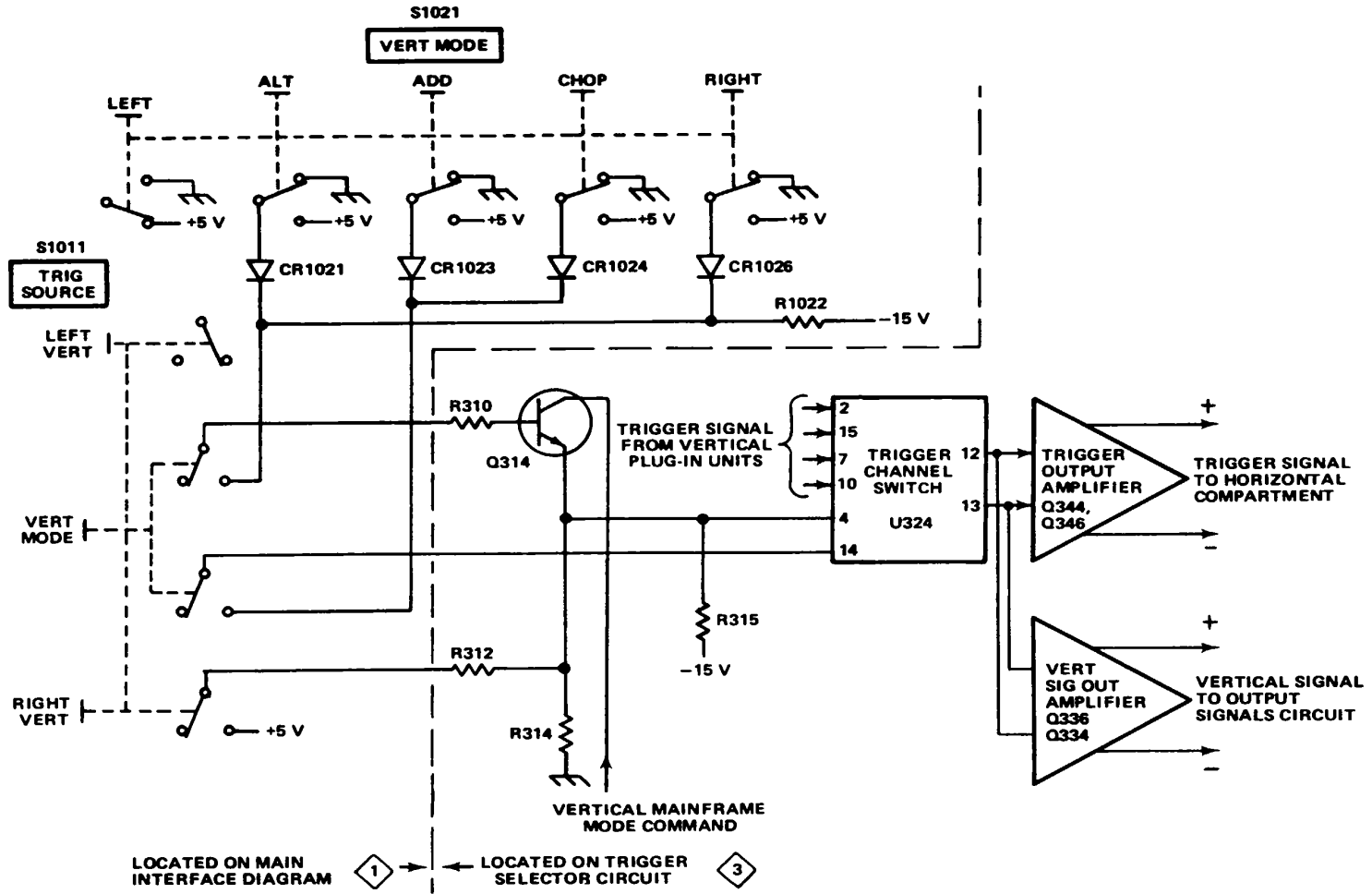
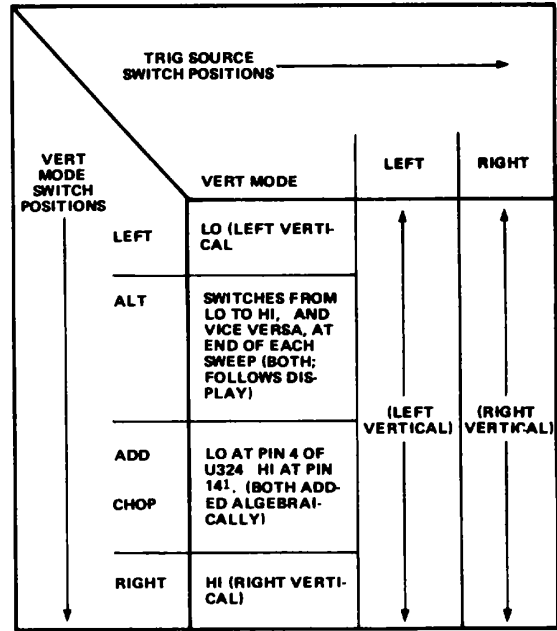

Figure 3-13. Detailed block diagram of Trigger Selector circuit along with simplified diagram of trigger source selection circuitry.

(A)

When the VERT MODE switch is set to ALT, +5 volts is applied to the base of 0314 through CR1021 and S1011. Q314 is forward biased and its emitter level is determined by the Mainframe Vertical Mode Command signal from the Logic circuit applied to its collector. This signal switches between the HI level (Right Vertical unit to be displayed) and the LO level (Left Vertical unit to be displayed) at the end of each sweep. When the Mainframe Vertical Mode Command is HI, it provides a positive collector voltage to 0314. 0314 is saturated due to CR1021, and its emitter level is very near the collector level. This provides a HI output level to the Trigger Channel Switch stage. As the Mainframe Vertical Mode Command goes LO, the collector supply for Q314 also goes negative. 0314 remains saturated and the output again follows the collector level to supply a LO output level to U324.

For ADD and CHOP vertical mode operation, +5 volts is connected to pin 14 of U324 through



¹ PIN 14 LO FOR ALL OTHER CONDITIONS

Figure 3-14. Input levels at pin 4 of U324.

CR1023 or CR1024 and S1011. At the same time the base of 0314 is held LO by the ground connection through the ALT and RIGHT section of S1021 so the level at pin 4 of U324 is LO also (produces an ADD mode in Trigger Channel Switch, see description of this circuit which follows). In the RIGHT position of the VERT MODE switch, +5 volts is connected to the base of 0314 through CR1026 and S1011 to forward-bias the transistor. The Mainframe Vertical Mode Command signal connected to the collector of Q314 is also HI in this mode, and a HI output level is produced at the emitter of 0314.

LEFT

When the LEFT trigger source is selected, the VERT MODE switch is disconnected from the trigger selector circuitry. Now the ground connection through the RIGHT section of S1011 establishes a LO output level at the emitter of Q314.

RIGHT

In the RIGHT position of the TRIG SOURCE switch, +5 volts is connected to the emitter of 0314 through S1011 and R312. This produces a HI output level to the Trigger Channel Switch stage.

TRIGGER CHANNEL SWITCH

The Trigger Channel Switch stage determines which input signal provides the trigger signal to the horizontal compartment as controlled by the Trigger Mode and ADD signals from the trigger selection circuitry. Refer to diagram 3 during the following discussion.

(A)

Theory of Operation-7623A/R7623A Service

Resistors R317-R319 establish the input resistance and provide a load for the trigger signal from the right vertical plug-in unit. Resistors R307 and R308 provide the input resistance and load for the left vertical plug-in unit. R321-R323-R324 and R326-R327-R328 establish the operating level of the Trigger Channel Switch, R321-R323 and R326-R328 set the current gain for each channel. This stage is made up primarily of integrated circuit U324. An input/output table for U324 is shown in Fig. 3-15. U324 provides a high impedance differential input for the trigger signal from the left vertical unit at pins 2 and 15, and for the trigger signal from the right vertical unit at pins 7 and 10. The output signal at pins 12 and 13 is a differential signal. The sum of the dc current at pins 12 and 13 is always equal to the sum of the dc currents at pins 1, 8, 9, and 16 in all modes. This provides a constant dc bias to the stages which follow as the TRIG SOURCE or the VERT MODE switches are changed.

When the level at pin 4 is LO (see Trigger Mode and ADD Signals discussion and Fig 3-15), the trigger signal from the left vertical unit passes to the output, while the trigger signal from the right vertical unit is blocked. A HI level at pin 4 connects the trigger signal from the right vertical unit to the output and the trigger signal from the left vertical unit is blocked. For VERT MODE operation in the ALT position of the VERT MODE switch, the level at pin 4 switches between the LO and HI level at a rate determined by the Vertical Binary stage (see Logic circuit description) This action obtains the trigger signal from the left vertical unit when the left vertical unit is being displayed and from the right vertical unit when it is being displayed.

When the level at pin 4 is LO and the level at pin 14 is HI, the trigger signal from both the left and right vertical units passes to the output pins. This condition occurs only when the TRIG SOURCE switch is set to VERT MODE and the VERT MODE switch is set to either ADD or CHOP Under this Operation mode, the trigger output signal is the algebraic sum of the trigger input signals from the left and right vertical units to prevent triggering on the vertical chopping transition, or only on one signal of an added display

INPUT		OUTPUT
TRIGGER MODE SIGNAL	TRIGGER ADD	TRIGGER OUTPUT SIGNAL
4	14	12,13
LO	LO	LEFT TRIGGER SIGNAL
HI	LO	RIGHT TRIGGER SIGNAL
LO	HI	BOTH (ADDED ALGEBRAICALLY)

Figure 3-15. Input/output table for Trigger Channel Switch stage.

TRIGGER OUTPUT AMPLIFIER

The trigger output at pins 12 and 13 of U324 is connected to the bases of Q344-Q346 to provide the internal trigger signal for the horizontal unit (via the Main Interface circuit) The horizontal unit provides a 50-ohm differential load for this stage. If it is removed from its compartment, the collector load for Q344-Q346 changes and the voltage at their collectors increases. This stage prevents this change from affecting the Vertical Signal to the Output Signal board CR341 and CR349 clamp the collectors of Q344 and Q346 at about +0.6 volt to prevent these transistors from saturating under this no-load condition

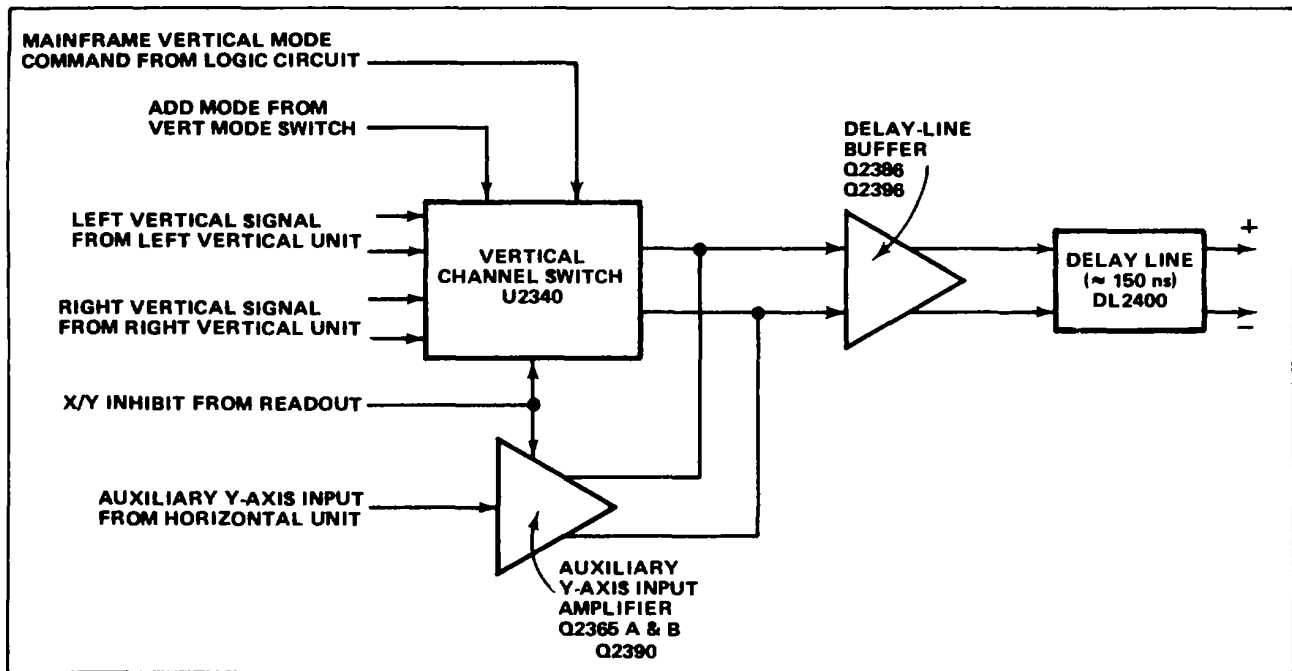

Figure 3-16. Vertical Interface detailed block diagram.

VERTICAL SIGNAL BUFFER

The trigger output signal at pin 12 and 13 of U324 is also connected to the emitter of a common-base amplifier Q336 and Q334. The output signal at the collector of Q336 and Q334 is connected to the signals out board.

VERTICAL INTERFACE <4>

The Vertical Interface circuit selects the vertical deflection signal from the output of the left or right vertical plug-in unit. Figure 3-16 is a detailed block diagram of the Vertical Interface circuit. A schematic of this circuit is shown on diagram 4.

VERTICAL CHANNEL SWITCH

The Vertical Channel Switch stage (controlled primarily by the Mainframe Vertical Mode Command from the Logic circuit) determines which vertical signal is to be sent to the Delay-Line Driver stage. Resistors R2333-R2335 and R2337-R2339 establish the input resistance of this stage and provide a load for the left and right vertical units. Resistors R2347-R2349 and R2357-R2359-R2329 establish the operating levels for this stage. R2343 and R2353 set the current gain for each channel. C2345-R2345 and C2355-R2355 provide frequency compensation.

The Vertical Channel Switch stage is made up primarily of integrated circuit U2340, which is the same type as used for the Trigger Channel Switch. An input/output table for U2340 is shown in Figure 3-17. U2340 provides a high impedance differential input for the signal from the left vertical unit at pins 2 and 15, and the signal from the right vertical unit at pins 7 and 10. The output signal at pins 12 and 13 is a differential signal that is connected to the Delay-Line Driver stage through R2366-R2376. The sum of the dc output currents at pins 12 and 13 is always equal to the sum of the dc input currents at pins 1, 8, 9, and

(A)

Theory of Operation-7623A/R7623A Service

Theory of Operation-7623A/R7623A Service 16 in all modes. This provides a constant dc bias to the following stage as the VERT MODE switch is changed

When the VERT MODE switch is set to LEFT, the level at pin 4 is LO. This level allows the signal from the left vertical unit to pass to the output while the signal from the right vertical unit is blocked. In the RIGHT position of the VERT MODE switch, the level at pin 4 is HI. Now, the signal from the right vertical unit is connected to the output while the signal from the left vertical unit is blocked.

When the VERT MODE switch is set to either ALT or CHOP, the Mainframe Vertical Mode Command at pin 4 switches between the LO any HI levels at a rate determined by either the Chop Counter or the Vertical Binary stages (see Logic circuit

INPUT			OUTPUT
MAINFRAME VERTICAL MODE COMMAND	ADD MODE (VERT)	X-Y SHUTDOWN (OFF)	OUTPUT SIGNAL
4	14	6	12, 13
LO	LO	LO	LEFT VERTICAL SIGNAL
HI	LO	LO	RIGHT VERTICAL SIGNAL
LO	HI	LO	BOTH (ADDED ALGEBRAICALLY)
LO	LO	HI	NEITHER (OFF)

LO \approx -0.6 V HI \approx +1.1 V

Figure 3-17. Input/output table for Vertical Channel Switch.

description) This action allows the signal from the left vertical unit to be displayed when the Mainframe Vertical Mode Command is LO and the signal from the right vertical unit is displayed when the Mainframe Vertical Mode Command is HI. When ADD vertical mode operation is selected, a HI level is applied to pin 14 and the level at pin 4 is LO as determined by the Vertical Mode Control stage in the Logic Circuit. This allows both the right and left vertical signals to pass to the output pins. Now, the signal from both vertical units is algebraically added and the resultant signal determines the vertical deflection

The X/Y Inhibit signal from the Readout system is applied to pin 6 of U2340. It has final control over the output signal from U2340. When the X/Y Inhibit signal is LO, the signal from the selected vertical can pass to the output pins 12 and 13. However, when the Readout system is ready to display Readout information, the level at pin 6 of U2340 goes HI and signals from both vertical compartments are blocked. The auxiliary Y-axis Amplifier is also disabled by the X/Y Inhibit signal

AUXILIARY Y-AXIS INPUT AMPLIFIER

The Auxiliary Y-Axis Input Amplifier accepts an input from horizontal plug-in units having compatible features. For example, a trace separation voltage to offset a delayed display. The single-ended signal connected to the input of this stage is converted to a push-pull signal at the collectors of Q2365 A and B. Q2390 permits the X/Y Inhibit to turn off this amplifier

DELAY-LINE BUFFER

The output of the Vertical Channel Switch stage, along with any signal from the Auxiliary Y-Axis Input Amplifier, is connected to the bases of Q2386 and Q2396. These transistors are connected in a common emitter shunt feedback configuration to provide a low impedance summing point, and voltage gain. L2386-L2396 and C2387-R2387, C2397-R2397, and C2398-R2398-R2388 improve both the high-frequency response and the reverse impedance termination for the Delay Line.

DELAY LINE

Delay Line DL2400 provides approximately 150 nanoseconds delay for the vertical signal, to allow the horizontal circuits time to initiate a sweep before the vertical signal reaches the vertical deflection plates of the crt. This allows the instrument to display the leading edge of the signal originating the trigger pulse when using internal triggering. The delay line used in this instrument has a characteristic impedance of about 50 ohms per side, and 100 ohms differentially.

VERTICAL AMPLIFIER <4>

The Vertical Amplifier circuit provides final amplification for the vertical signal before it is applied to the vertical deflection plates of the crt. This circuit includes an input from the BEAMFINDER switch to compress an overscanned display within the viewing area of the crt. Figure 3-18 shows a detailed block diagram of the Vertical Amplifier circuit. A schematic of this circuit is shown on diagram 4 in the diagrams section

CENTERING AND READOUT AMPLIFIER

Q2530-Q2430 compose a paraphase amplifier to provide balance or centering control for the Vertical Amplifier by changing the ratio of the current that is summed at the emitters of Q2441-Q2541. In addition, this stage provides the input for the vertical readout signal through j2534 and the base of Q2530.

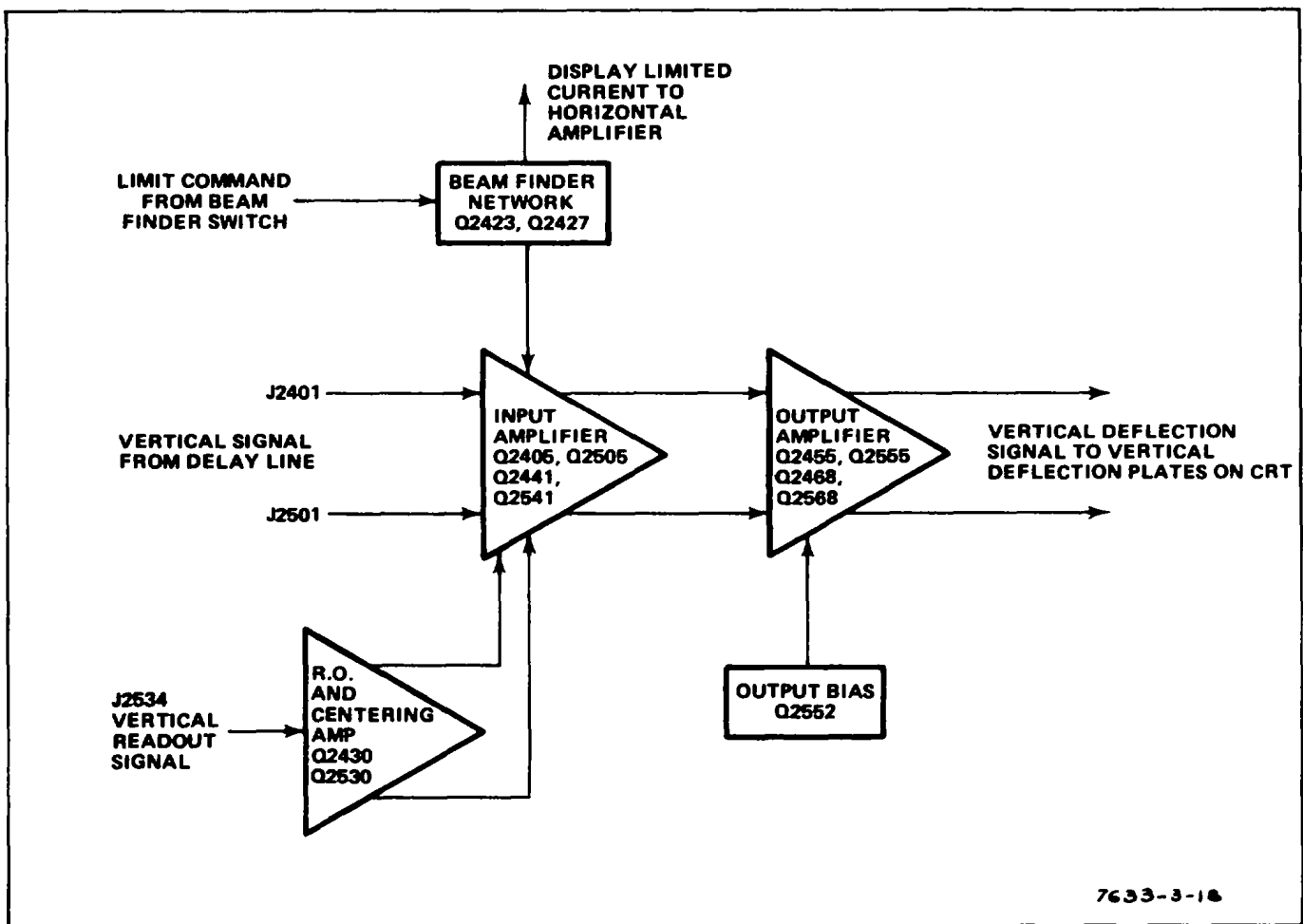

Figure 3-18. Vertical Amplifier detailed block diagram.

(A)

Theory of Operation-7623A/R7623A Service

INPUT AMPLIFIER

Forward termination of the delay line is accomplished by R2402-R2502, In conjunction with the input impedance of Q2405-Q2505 R2402-R2502 also act as load resistors for the Delay-Line Buffer stage Q2405-Q2441-Q2505-Q2541 are connected in a cascade configuration The RC networks In the emitters of 02405-02505 compensate for the losses In the delay line and provide some temperature compensation for the Vertical Amplifier

The emitter current of Q2405-Q2505 is returned through the Beam Finder switch Q2423. When the Beam Finder is activated, Q2423 is turned off and the current path is through R2423, thus reducing the dynamic range of the input amplifier to limit the display vertically within the graticule area.

Thermal balancing of the vertical amplifier is accomplished by R2527, which adjusts the base voltage of Q2441-Q2541

The signal from Q2441-Q2541 is connected to the output amplifier through the transmission line, which is terminated by L2448-L2548 and R2448-R2548. The vertical gain is adjusted by R2446, a shunt across the collectors of Q2441-Q2541

BEAMFINDER NETWORK

The Beamfinder Network provides a means of locating a display that overscans the graticule area Under normal operation, the Display Limit Command is at -15 volts, which holds Q2427 cut off and allows Display Limited Current for the Horizontal Amplifier to rise to about +8 volts. During this time, Q2423 is held on and emitter current from Q2405-Q2505 flows through Q2423 to ground When the BEAMFINDER switch is pressed, the Display Limit Command rises positive, turning Q2427 on and Q2423 off. This pulls the Display Limit Current to -15 volts, and reduces the emitter current of Q2405- Q2505 to a level that limits the dynamic range of the input stage R2523-R2524 serve to maintain the proper common mode voltage at the output of the amplifier when the BEAMFINDER is used

OUTPUT AMPLIFIER

The output cascade amplifier is driven through "T coils" to increase high frequency gain. High-frequency compensation is provided by C2456 and the varactor network in the emitters of Q2455-Q2555.

Output common base stage Q2468-Q2568 is driven through the RC matching networks between the collectors of Q2455-Q2555 and emitters of Q2468-Q2568 The output signal at the collectors of Q2468- Q2568 provides the vertical deflection signal for the crt

(A)

HORIZONTAL AMPLIFIER<5>

The Horizontal Amplifier circuit amplifies the push-pull horizontal deflection signals from the plug-in unit in the horizontal compartment and connects it to the horizontal deflection plates of the crt. Figure 3-19 shows a detailed block diagram of the Horizontal Amplifier circuit. A schematic of this circuit is shown in the diagrams section at the rear of this manual.

HORIZONTAL CHANNEL SWITCH

Signals from the plug-in unit in the horizontal compartment are connected to pins 2 and 15 of integrated circuit U510. The X Readout signal is connected to pin 7 of U510. U510 determines which input signal will be applied to the Horizontal Amplifier circuit. This is controlled by the X/Y Inhibit signal from the Readout System. When the X/Y Inhibit signal is LO, the signal from the horizontal compartment is passed to the output of U510. When the X/Y Inhibit is HI, the X Readout signal is passed to the output of U510. Resistors R514, R515, R521, and R522 establish the operating levels for this circuit. The range of Gain adjustment R512 is established by R511 and R513. The output is a differential signal connected to the Horizontal Amplifier circuit. For a more detailed explanation of the channel switch operation, see

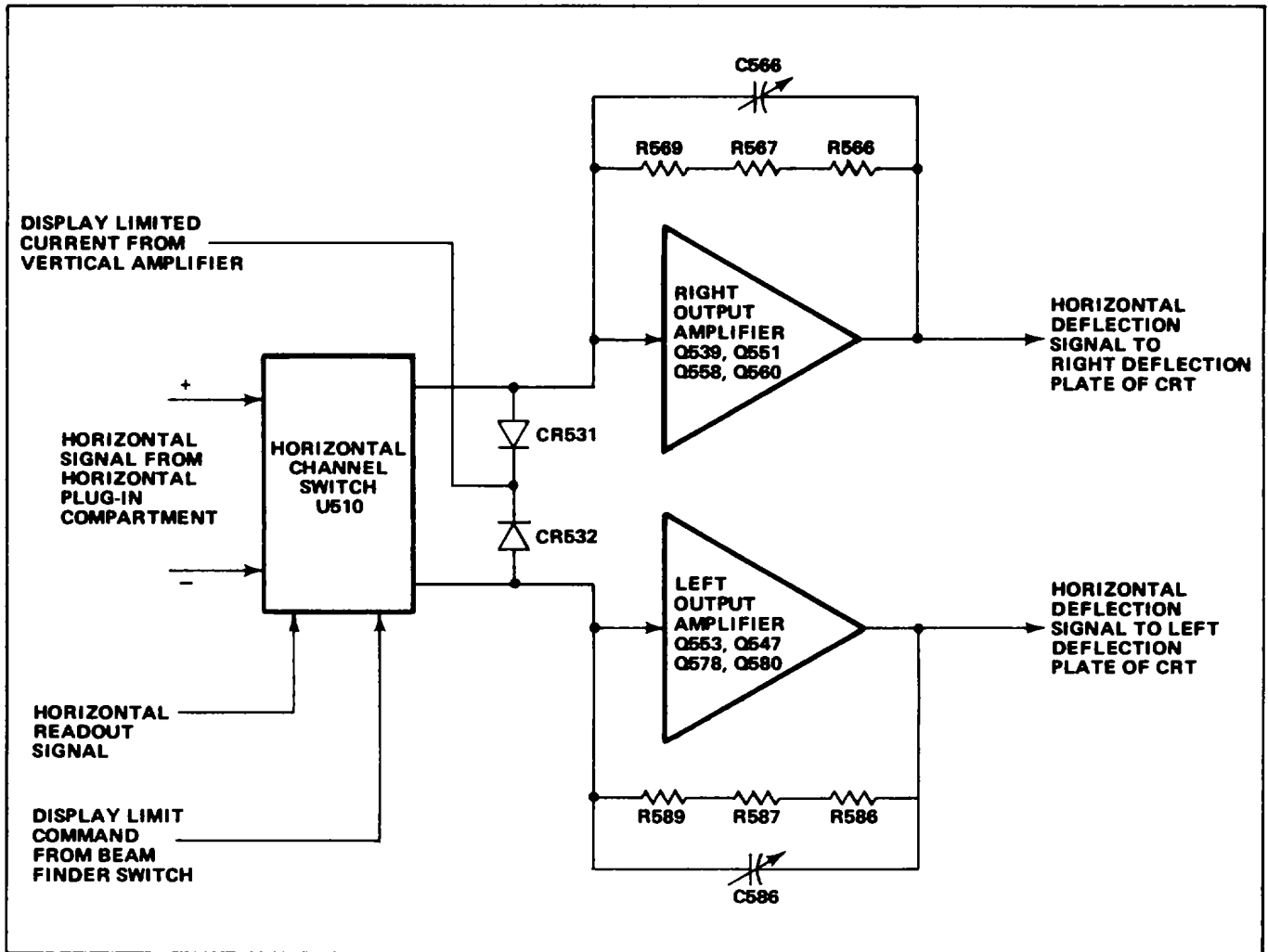

Figure 3-19. Horizontal Amplifier

(A)

Theory of Operation-7623A/R7623A Service

connected to the Horizontal Amplifier circuit. For a more detailed explanation of the channel switch operation see Trigger Channel Switch under Trigger Selector.

For normal operation, the Limit Command is connected to the -15 supply through the BEAM-_% FINDER switch. When the BEAMFINDER switch is actuated, the -15 volts is interrupted to limit the current to U510. At the same time, current is added through CR531 and CR532 from the Display Limited Current line. This maintains the same dc currents to the output amplifier in both positions of the BEAM- FINDER switch. The signal at the output is connected to the left and right amplifiers. R525 adjusts the amplifier for center screen deflection with no signal.

RIGHT OUTPUT AMPLIFIER

Transistors Q539, Q551, Q558, and Q560 are connected as a current-driven feedback amplifier. The input current is converted to a voltage output signal to drive the right horizontal deflection plate of the crt. The signal at the collector of Q539 is connected to the emitters of output transistors Q558-Q560 through emitter follower Q551 and parallel paths C555-R555 and R563. The signal is connected to the emitter of Q560 through R563. The output transistors Q558 and Q560 are connected in the complementary configuration to provide less resistive loading at the output. The output signal at the collectors of Q558-Q560 is connected to the right deflection plate of the crt through R565.

The crt deflection plates present a capacitive load to the amplifier, which requires additional current during a fast sweep. Extra current for positive excursions is provided by Q551 via R555, C555, and Q558 and for negative excursions, via R563 and Q560.

Resistor R556 reduces the power dissipation in Q558 and resistor R560 reduces dissipation in Q560. Resistors R566, R567, and R569 provide dc feedback and establish low frequency gain. Capacitors C566 and C588 are adjusted for correct gain at fastest sweep rates. C584-R584 provide thermal compensation.

LEFT OUTPUT AMPLIFIER

Basic operation of the Left Output Amplifier stage is the same as just described for the Right Output Amplifier. C586 provides linearly adjustment for the Left Output Amplifier at fast sweep rates. The output signal at the collectors of Q578-Q580 is connected to the left deflection plate of the crt through R585.

The series circuit CR549 and R549 stabilize the output amplifier during fast retrace intervals. R535 is adjusted to balance the negative excursions of the Right and Left Output Amplifier when the time base plug-in is used in X10 Magnified mode.

Theory of Operation-7623A/R7623A Service

OUTPUT SIGNALS

The Output Signals circuit provides outputs to connectors mounted on the rear panel of the 7623A. A schematic of this circuit appears in the diagrams section of this manual. Option 7 Instruments do not contain this circuit.

VERT SIG OUT

The vertical signal is selected by the TRIG SOURCE switch. The vertical signal selected is applied to the bases of a differential amplifier Q606 and 0618. A single-ended signal is taken off the collector of 0618 and connected to an output buffer Q620. CR621 and CR622 provide protection against a high voltage inadvertently applied to the output connector.

+ GATE OUT

The gate signal is connected to a comparator circuit 0662 and 0666 through resistor R660. From the comparator the gate signal is connected to the emitter of an output buffer 0672. Gate Selector switch S659 connects one of the gate signals to R660, the input of the Gate Amplifier. Possible gate signals are MAIN gate and, with a dual-sweep time-base unit, a DELAY or an AUXILIARY gate signal can be selected. CR674 and CR676 provide protection against a high voltage inadvertently applied to the output connector.

+ SAWTOOTH OUT

The sawtooth signal is connected to the Sawtooth Amplifier through R36. Q631, 0634, and 0640 comprise a negative feedback amplifier with a gain of two, determined by the ratio of feedback resistor R645 to the combined input resistance of R630 and R63. CR635 and CR676 provide protection against a high voltage inadvertently applied to the output connector.

CRT CIRCUIT <7>

The CRT Circuit produces the high-voltage potentials and provides the control circuits necessary for operation of the cathode ray tube (crt). This circuit also includes the Z-Axis and Auto Focus Amplifier stages. Figure 3-20 is a detailed block diagram of the CRT Circuit. A schematic of this circuit is shown on diagram 7 in the diagrams section.

T1199 and 01195 form a tuned-tank, sine-wave oscillator. Transformer T1199 has four secondary windings, the high-voltage winding, a 600 volt supply winding, a heater winding, and an oscillator feedback winding.

HIGH VOLTAGE REGULATION

The high-voltage tap on the secondary of T1199 is the source of current for the cathode of the crt. The ac is rectified through CR1213 and filtered by C1213, R1214, and C1214 to provide approximately

(A)

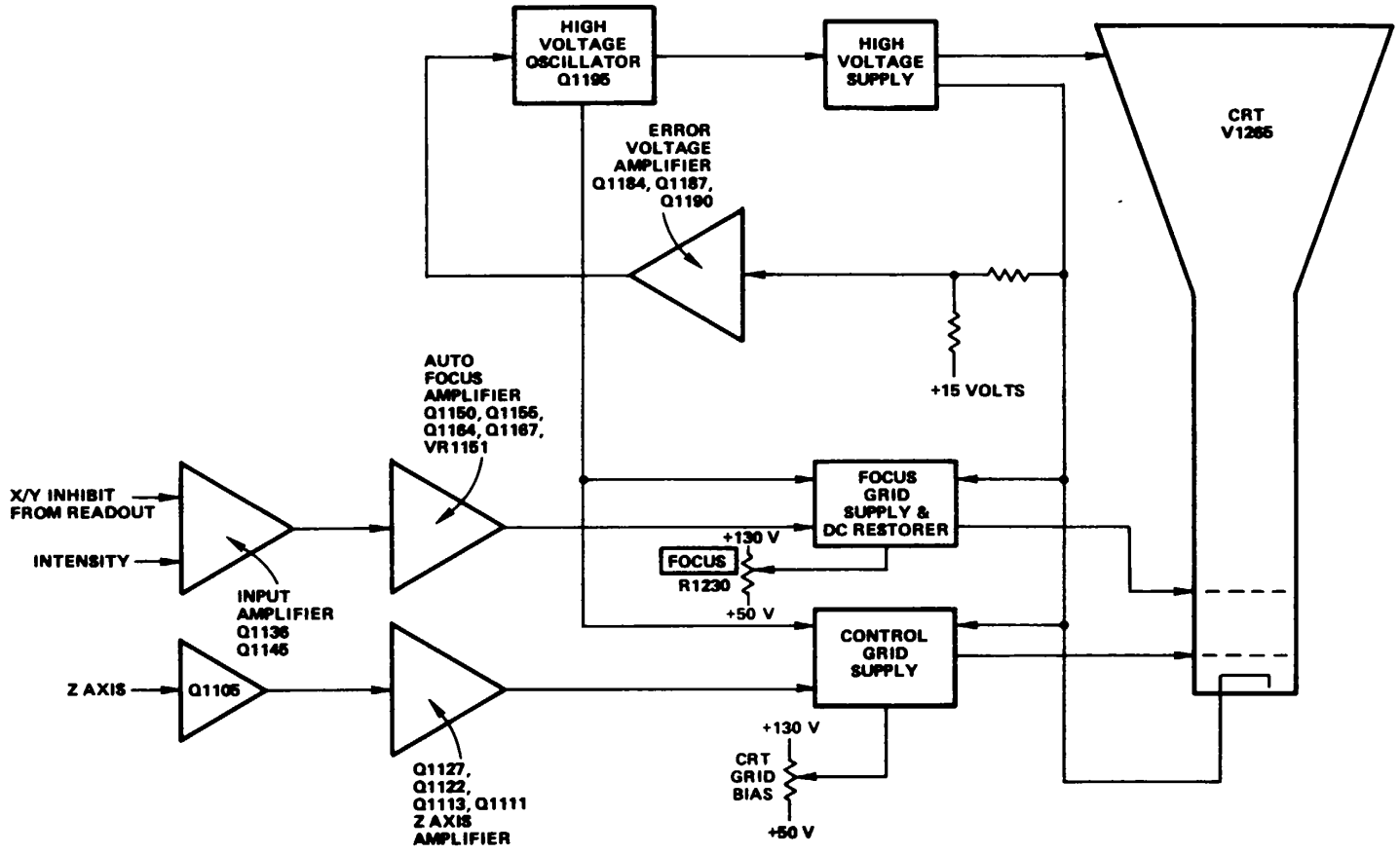

Figure 3-20. CRT Circuit detailed block diagram.

-1500 volts to the cathode. In order to maintain a constant voltage on the cathode, this same tap serves to reference the feedback path to the oscillator. R 1 226A and R 1 226B (part of the same substrate for good stability) form a divider network. The signal at the junction of these two resistors is applied to the base of Q1184. This signal is an error voltage determined by comparing the cathode voltage against a positive voltage of approximately 15.6 volts appearing at the anode of CR1223.

The difference signal is amplified through Q1184 and Q1187 and applied to the base of emitter follower Q1190. The output of Q1190 is fed to the base of oscillator transistor Q1195 through the primary winding of T1199. The base winding ac return is provided by C1193. Resistor R1192 provides a fixed value current for the oscillator. This stabilizes the network by preventing the oscillator from stopping during the times the feedback network is shut off.

The top of the high-voltage winding supplies the positive accelerating potential for the crt anode. The anode supply is a voltage doubler consisting of C1201, CR1202, CR 1203, C1202, R1204, R1205, R1206, and C1 206. R1207 and R1208 provide electrical damping of mechanical resonance in the crt meshes.

The crt heater voltage is supplied directly by the heater winding of the transformer secondary. The cathode and heater are connected through R 1263 to prevent cathode-to-heater breakdown due to the large difference in potential between these two crt elements.

AUTO FOCUS DC RESTORER

The focus electrode is supplied by a voltage from the wiper arm of the Focus Preset control, R1242 through R1240 and R1239. The focus of the display is determined by the FOCUS control, R1230. This control and the Auto Focus Amplifier maintain a well defined display under varying Intensity conditions. The network consisting of CR1234, CR1238, CR1239, CR1233, VR1233, C1237, and C1238 provide a varying negative voltage translated to the proper dc level, for the focus grid of the crt. An ac voltage from the 600-volt winding of the transformer secondary is connected to the focus grid supply through C1235, R1235, and R1236. The positive clipping level at the junction of VR1233 and CR1234 is determined by the FOCUS control setting. The negative clipping level at the anode of CR1234 is determined by the output level of the Auto Focus Amplifier.

A change in the intensity level, as changes in the peak-to-peak values of the ac voltage, is coupled to the focus grid from the Auto Focus Amplifier through R1166 and C1238. This ac signal is introduced through CR1238 and CR 1239 to vary the dc signal across R 1239. Focus is adjusted by the front panel FOCUS control R1230.

(A)

Theory of Operation-7623A/R7623A Service

AUTO FOCUS

The X/Y Inhibit signal from the Readout System determines the switching between Q1136 and Q1145, readout intensity or display intensity respectively. The conduction of either of these transistors, through R 1147 sets the level at the base of Q1150. Q1150, Q1155, Q1164, and Q1167 comprise an analog feedback amplifier. The conduction of Q1150 controls the signal at the collector of Q1167. This signal is fed back to the base of Q1155 through a divider network. Q1155 and Q1150 form a differential amplifier which compares the focus signal with that of the Intensity input at the base of Q1150.

CONTROL-GRID DC RESTORER

The Control-Grid DC Restorer couples dc and low frequency components of the Z-Axis Amplifier signal to the crt control grid. This allows the Z-Axis Amplifier to control the crt beam current (intensity). The potential difference between the Z-Axis Amplifier output and the control grid (about 3000 volts) prohibits direct coupling.

The dc restorer is actually a cathode-referenced bias supply for the crt control grid. Quiescently, its output voltage is more negative than the cathode by an amount set by Crt Grid Bias adjustment R 1248.

The network consisting of diodes CR1251, CR 1255, CR 1257, and CR1258, provides the negative voltage for the control grid of the crt. Output level of this supply is set by Crt Grid Bias adjustment R1248. Approximately 600 volts peak-to-peak from the secondary of T1199 is connected to the Control Grid Supply through C1253, R 1253, and R 1254. CR 1255 and CR 1251 clip this signal to determine the operating level at the control grid. CR1255 limits the negative excursion of the signal. Quiescently, when the crt is blanked, the anode of CR1255 is set at about +15 volts by the Z-Axis Amplifier stage. The positive clipping level at the cathode of CR1251 is set by Crt Grid Bias adjustment R1248. R1248 is adjusted to bias the control grid of the crt just enough negative so the trace is blanked between sweeps.

The negative level at the crt cathode, held constant by the High-Voltage Regulator, is connected through R1259 to the cathode of CR1258. The clipped voltage developed by CR1251 and CR1255 is peak-to-peak rectified by CR1257 and CR1258 and super-imposed on this negative level. This results in a grid level, which is more negative than the crt cathode level. C1255 acts as a filter to provide a constant voltage output level. The unblanking gate level developed by the Z-Axis Amplifier stage is applied to the anode of CR1255 through R 1118. Fast rising and falling portions of this signal are coupled directly to the crt grid through C1255.

Z-AXIS AMPLIFIER

The Z-Axis Signal from the Logic circuit and the Z-Readout signal from the Readout System are connected to the emitter of Q1105. Transistor Q1105 is a common-base amplifier to establish a low input

(A)

Impedance for the input signals. Transistors Q1127, Q1122, Q1113, and Q1111 form a current driven operational amplifier. The input and output transistors are complementary to provide a fast rise-time and a fast fall-time response with minimal standing current. Resistor R 1123 establishes a low current in the series connected output transistors. Transistor Q1127 supplies additional current through C1124 for the positive transients, and transistor Q1111 supplies additional current for negative transients. Capacitor C1115 is adjusted for optimum square-wave output, resistors R 1115 and R 1116 along with capacitor C1115 form the feedback network. Zener diode VR 1109 provides the necessary change of voltage from the collector of Q1105 to the base of Q1111.

CRT CONTROL CIRCUITS

Astigmatism adjustment R1274, which is used in conjunction with the FOCUS control to obtain a well-defined display, varies the positive level on the astigmatism grid. Geometry adjustment R1292 varies the positive level on the horizontal deflection-plate shield to control the overall geometry of the display.

Two adjustments control the trace alignment by varying the magnetic field induced by coils around the crt. Y-Axis Alignment R1284 controls the current through L1284, which affects the crt beam after vertical deflection, but before horizontal deflection. Therefore, it affects only the vertical (Y) components of the display. TRACE ROTATION adjustment R 1286 controls the current through L1295 and affects both the vertical and horizontal rotation of the display.

LOW-VOLTAGE POWER SUPPLY <8>

The Low-Voltage Power Supply circuit provides the operating power for this instrument from six regulated supplies. Electronic regulation is used to provide stable, low-ripple output voltages. Each supply contains a short-protection circuit to prevent instrument damage. If a supply is inadvertently over-loaded or shorted to ground, Figure 3-21 shows a detailed block diagram of the Low-Voltage Power Supply circuit. A schematic of this circuit is shown on diagram 8 at the rear of this manual.

POWER INPUT

Power is applied to the primary of transformer T801 through line fuse F1000, thermal cutout S1000, and POWER switch S1001. The Voltage-Selector Jumper, P1001, connects the two halves of the primary of T801 in parallel for 110-volt (nominal) operation. Voltage-Selector Jumper P1002 connects the two halves of the primary in series for 220-volt (nominal) operation. The line fuse, F1000, must be changed to provide the correct protection for 220-volt nominal operation.

Each half of the primary of T801 has taps above and below the 110-volt (220-volt) nominal point. When the Voltage Selector Jumper is moved from LOW to MED to HI, more turns are effectively added to the primary winding and the turns ratio is decreased to compensate for the increased primary voltage. This configuration extends the regulating range of the 7623A.

(A)

Theory of Operation-7623A/R7623A Service

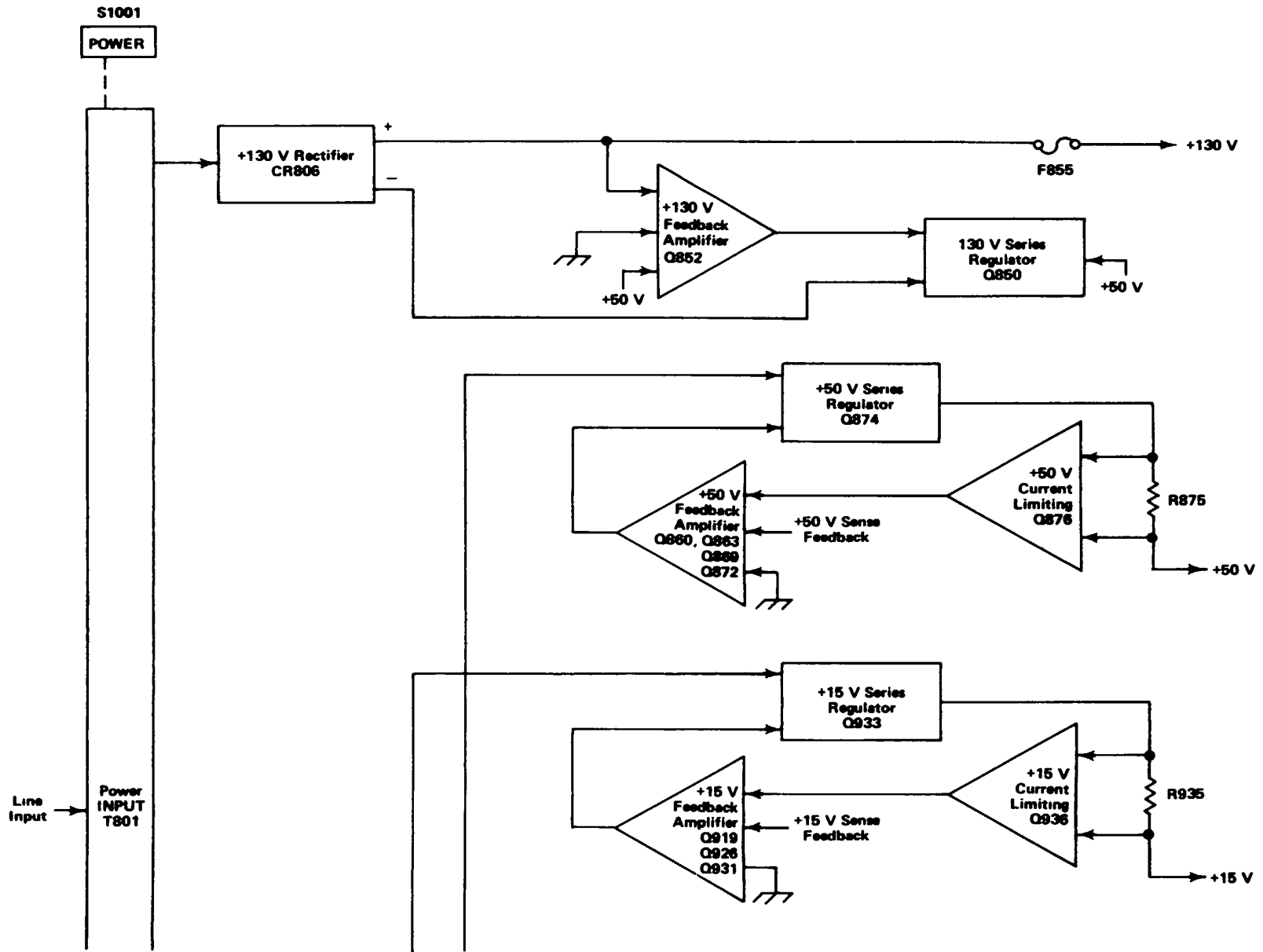

Theory of Operation-7623A/R7623A Service

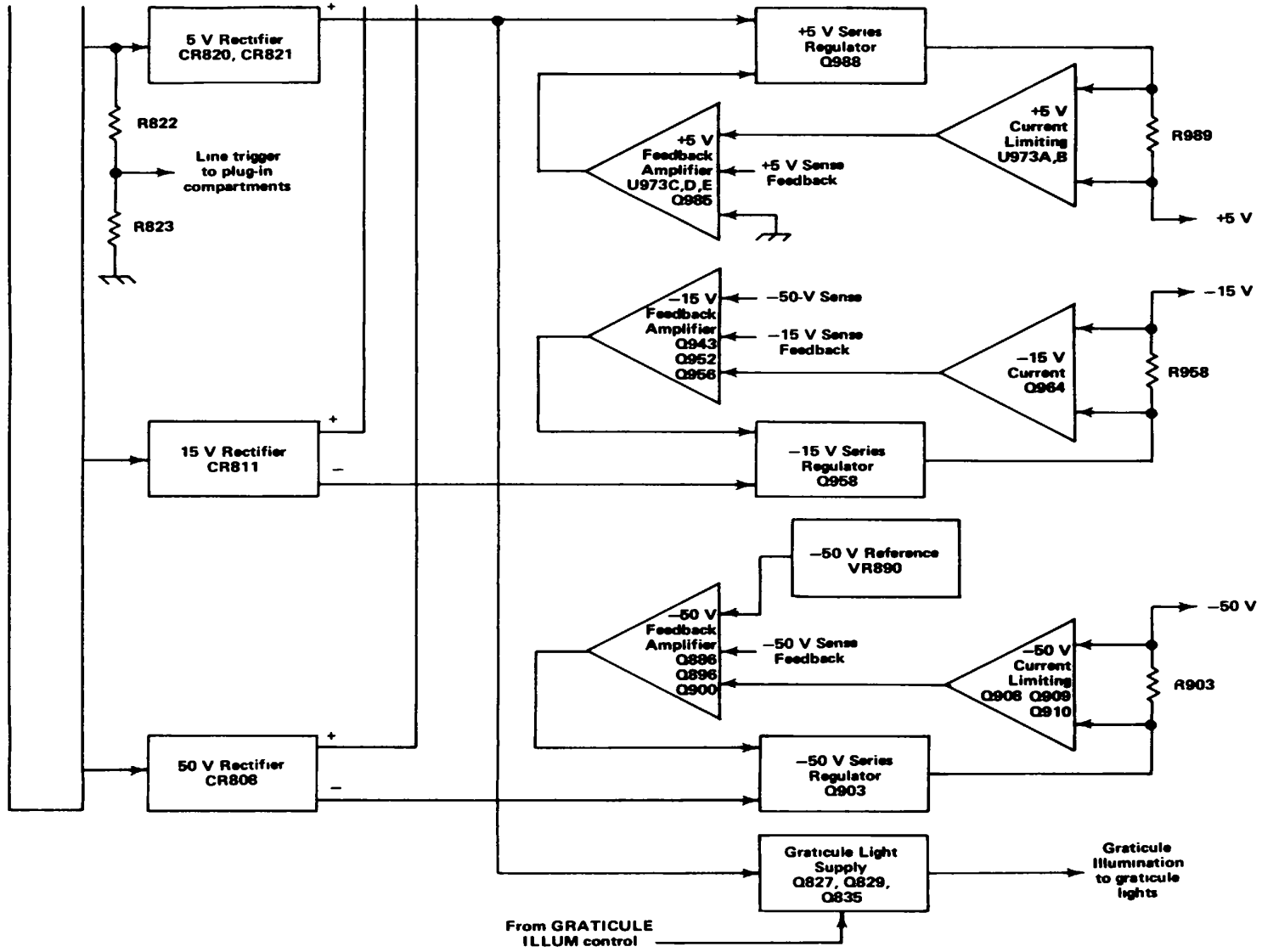

Figure 3-21. Low-Voltage Power Supply detailed blocked diagram.

(A)

Theory of Operation-7623A/R7623A Service

A fan provides forced-air cooling for the 7623A. The fan is connected in parallel with one half of the primary winding of T801. Therefore, it always has the same voltage applied regardless of the position of the Voltage-Selector Jumper

Thermal cutout S1000 provides thermal protection for this instrument. If the internal temperature of the instrument exceeds a safe operating level, S1000 opens to interrupt the applied power. When the temperature returns to a safe level, S1000 automatically closes to re-apply the power

-50-VOLT SUPPLY

The following discussion includes the description of the 50 V Rectifier, -50 V Series Regulator, -50 V Feedback Amplifier, -50 V Reference, and -50 V Current Limiting stages. Since these stages are closely related in the operation of the -50-volt regulated output, their operation is most easily understood when discussed as a unit.

The 50 V Rectifier assembly CR808 rectifies the output at the secondary of T801 to provide the unregulated voltage source for both the -50- and +50-Volt supplies. CR808 is connected as a bridge rectifier and its output is filtered by C808-C809. Transistors Q886, Q896, Q900 and Q903 operate as a feedback-stabilized regulator circuit to maintain a constant -50-volt output level. Q886 is connected as a differential amplifier to compare the feedback voltage at the base of Q886B against the reference voltage at the base of Q886A. The error output at the collector of Q886B reflects the difference, if any, between these two inputs. The change in error-output level at the collector of Q886B is always opposite in direction to the change in the feedback input at the base of Q886B (out of phase)

Zener diode VR890 sets a reference level of about -9 volts at the base of Q886A. A feedback sample of the output voltage from this supply is connected to the base of Q886B through divider R880-R881-R882. R881 in this divider is adjustable to set the output level of this supply. Notice that the feedback voltage to this divider is obtained from a line labeled -50 V Sense. Figure 3-22 illustrates the reason for this configuration. The inherent resistance of the interconnecting wire between the output of the -50-Volt Supply and the load produces a voltage drop which is equal to the output current multiplied by the resistance of the interconnecting wire. Even though the resistance of the wire is small, it results in a substantial voltage drop due to the high output current of this supply. Therefore, if the feedback voltage were obtained ahead of this drop, the voltage at the load might not maintain close regulation. However, the -50 V Sense feedback configuration overcomes this problem since it obtains the feedback voltage from a point as close as practical to the load. Since the current in the -50 V Sense line is small and constant, the feedback voltage is an accurate sample of the voltage applied to the load.

Regulation occurs as follows. If the output level of this supply decreases (less negative) due to an increase in load, or a decrease in input voltage (as a result of line voltage changes or ripple), the voltage across divider R880-R881-R882 decreases also. This results in a more positive feedback level at the base of Q886B than that established by the -50 V Reference stage at the base of Q886A. Therefore, the output current at the collector of Q886B increases. This increase in output from Q886B allows more current to flow through Q896 and Q900 to result in increased conduction of -50 V Series Regulator.

(A)

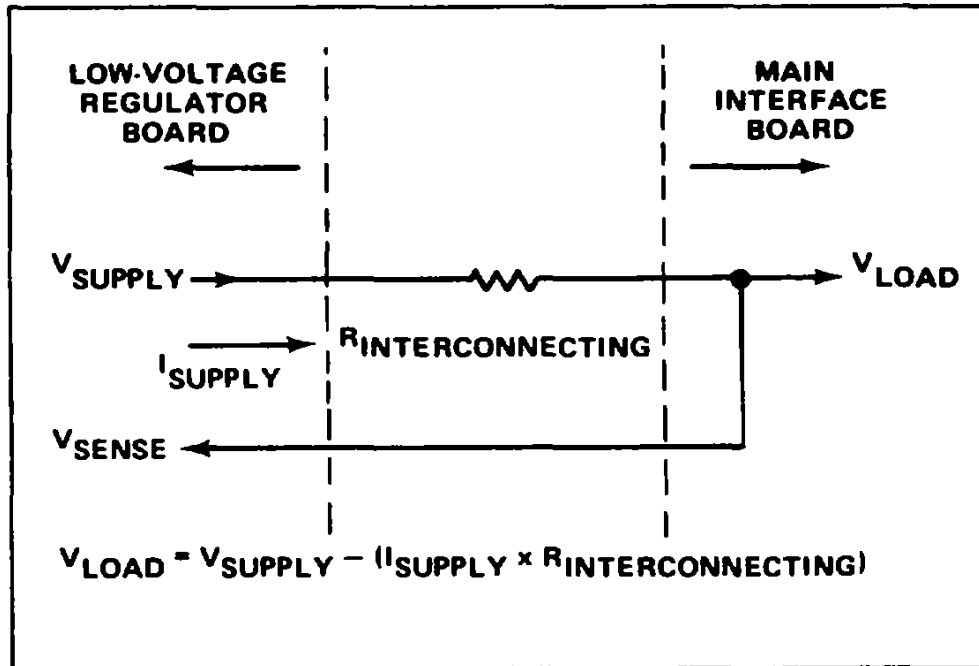

Figure 3-22. Schematic illustrating voltage drop between power supply output and load due to resistance of interconnecting wire

0903. The load current increases and the output voltage of this supply also increases (more negative). As a result, the feedback voltage from the -50 Sense line increases and the base of Q886B returns to the same level as the base of Q886A. Similarly, if the output level of this supply increases (more negative), the output current of Q886B decreases. The feedback through Q896 and Q900 reduces the conduction of the -50 V Series Regulator to decrease the output voltage of this supply.

-50 Volts adjustment R881 determines the divider ratio to the base of Q886B and thereby determines the feedback voltage. This adjustment sets the output level of the supply in the following manner: If R881 is adjusted so the voltage at its variable arm goes less negative (closer to ground), this appears as an error signal at the base of Q886B. In the same manner as described previously, this positive-going change at the feedback input of the differential amplifier increases the conduction of the -50 V Series Regulator to produce more current to the load, and thereby increase the output voltage of this supply. This places more voltage across divider R880-R881-R882 and the divider action returns the base of Q886B to about -9 volts. Notice that the feedback action of this supply forces a change in the output level which always returns the base of Q886B to the same level as the base of Q886A. In this manner, the output level of the -50-Volt Supply can be set to exactly -50 volts by correct adjustment of R881.

The -50 V Current Limiting stage Q908-Q909-Q910 protects the -50-Volt Supply if excess current is demanded from this supply. All of the output current from the -50-Volt Supply flows through R903. Transistor Q908 senses the voltage at the collector of the -50 V Series Regulator Q903 and compares it against the -50 V output level at the base of Q909 which is obtained from the other side of R903. Under normal operation, Q908 is held in conduction and Q909 is off. However, when excess current is demanded from the -50 V Series Regulator due to a short circuit or similar malfunction at the output of this supply, the voltage drop across R903 increases until the base of Q908 goes more negative than the level at the base of Q909. Then Q909 takes over conduction of the comparator. The collector current of Q909 increases the voltage drop across R896 to reduce the conduction of Q896 in the -50 V Feedback Amplifier and limit the conduction of Q903. Q910 is connected as a constant-current source for Q908-Q909.

(A)

Theory of Operation-7623A/R7623A Service

-15-VOLT SUPPLY

Basic operation of all stages in the -15-Volt Supply is the same as for the -50-Volt Supply. Reference level for this supply is established by divider R945-R946 between ground and the -50 V Sense voltage. The divider ratio of R945-R946 sets a level of -15 volts at the base of Q943A. The level on the -50 V Sense line is held stable by the -50-Volt Supply as described previously. The -15 V Sense voltage is connected to the base of Q943B through R940. Any change at the output of the -15-Volt Supply appears at the base of Q943B as an error signal. The output voltage is regulated in the same manner as described for the -50-Volt Supply.

+5-VOLT SUPPLY

Basic operation of the +5-Volt Supply is the same as described for the previous supplies. The +5 V Current Limiting and +5 V Feedback Amplifier (except for Q985) is made up of a five-transistor array U973. Notice that both U973C and Q985 in the +5 V Feedback Amplifier are connected as emitter followers, since Inversion Is not necessary in the feedback path for positive output voltages. Reference is established at 0 volt level by R975. Divider R970-R971, connected to both the +5 volt sense feedback and -50 volt sense feedback, establishes an error voltage at the base of U973E.

+15-VOLT SUPPLY

The +15-Volt Supply operates in the same manner as described for the previous supplies. The unregulated +15-Volt Supply provides the source voltage for the High-Voltage Oscillator stage in the crt circuit through fuse F814 and P870.

+50-VOLT SUPPLY

Operation of the +50-Volt Supply is the same as described for the previous supplies. The unregulated +50 volts, from 50 V Rectifier CR808, is used to provide a positive starting voltage for the -50- Volt Supply.

+130-VOLT SUPPLY

The +130-V Rectifier CR806 provides the rectified voltage for the +130-Volt Supply. However, this secondary winding of T801 does not supply the full potential necessary to obtain the +130-volt output level. To provide the required output level, the +50-Volt Supply is connected in series with this supply through Q850. Basic regulation of the output voltage is provided by +130 V Feedback Amplifier Q852, and +130 V Series Regulator Q850.

The output voltage of this supply is connected across divider R855-R856. This divider provides a quiescent level of about +50 volts at the base of Q852. The reference level for this supply is provided by the +50-Volt Supply connected to the emitter of Q852. If the output of this supply changes, this change is sensed by Q852 and an amplified error signal is connected to the base of Q850. This error

(A)

Theory of Operation-7623A/R7623A Service

signal changes the conduction of the +130 V Series Regulator Q850 to correct the output error. Fuse F855 protects this supply if the output is shorted. However, since the response time of F855 is slow to a shorted condition, VR851 provides additional current to the base of Q850 to protect Q852 from damage. Diode CR852 limits the reverse bias on Q852 to about 0.6 volt when F855 is blown.

GRATICULE LIGHT SUPPLY

Power for the graticule lights is supplied by the Graticule Light Supply. Rectified voltage for this supply is provided by 5 V Rectifier CR820-CR821. Q835 operates as a series regulator transistor. Emitter follower Q829 determines the conduction of this series regulator as controlled by front panel GRATICULE ILLUM Control R1095. Current-limiting to protect this supply is provided by Q827. Under normal operation, divider R830-R831-R833 sets the base of Q827 below its conduction level. However, if excess current is demanded from this supply, the voltage drop across R837-R838 increases until Q827 comes into conduction. The collector of Q827 then limits the conduction of this supply to limit its output current.

Divider R822-R823 provides a sample of the line voltage in the secondary of T801 to the plug-in unit. This provides a line-frequency reference to the plug-in units for internal triggering at line frequency or for other applications.

CALIBRATOR <10>

The Calibrator circuit provides output voltage to the front-panel Calibrator pin-jacks. Figure 3-23 shows a detailed block diagram of the Calibrator portion of this circuit. A schematic of this circuit is shown on diagram 10 at the rear of this manual.

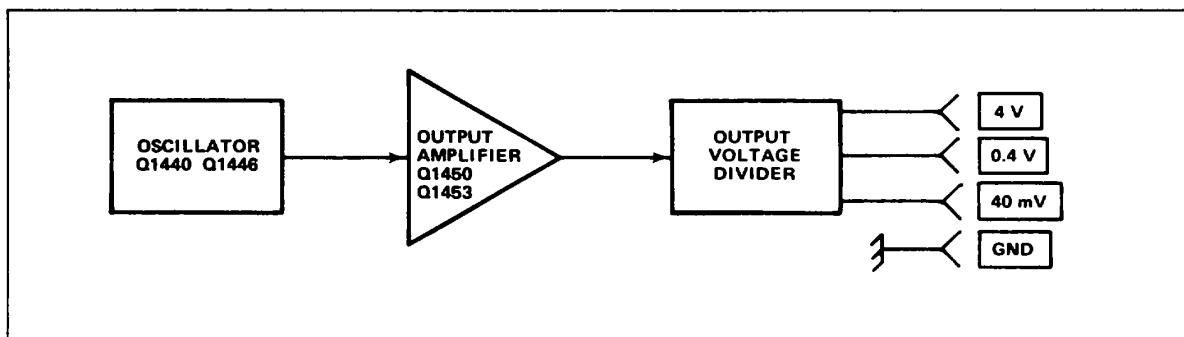

Figure 3-23. Calibrator details block diagram.

(A)

Theory of Operation-7623A/R7623A Service

CALIBRATOR

GENERAL

The Calibrator circuit provides accurate voltage output at the front-panel Calibrator pin-jacks. Repetition rate of the output signal is about one kilohertz.

OSCILLATOR

Q1440 and Q1446 are connected as a square-wave oscillator to determine the repetition rate of the Calibrator circuit. Oscillation occurs as follows. Assume that Q1440 is conducting and Q1446 is off. The collector voltage of Q1440 (determined by the voltage divider formed by R1440 and R1441) drops to the saturation level of Q1440. With this low voltage on its base, Q1446 is turned off. Since Q1446 is not conducting, its collector goes positive, producing the positive portion of the square wave, and its emitter drops to a level of about 0.6 volt more negative than its base and stops. As a result, the current through R1445 and C1444 is no longer available to Q1440. This forward biases Q1446, due to an increased base voltage, causing its emitter to rapidly rise positive. Since C1444 cannot change its charge instantaneously, the sudden change in voltage at the emitter of Q1446 pulls the emitter of Q1440 positive also, to reverse bias it. The current through Q1446 produces a voltage drop at its collector to produce the negative portion of the square wave.

Now, conditions are reversed. Since Q1440 is reverse biased, there is no current through it. Therefore, C1444 can begin to discharge through R1443. The emitter level of Q1440 follows the discharge of C1444 until it reaches about -0.6 volt. Then, Q1440 is forward biased and its collector drops negative to reverse bias Q1446. This interrupts the current through Q1446, and its collector goes positive again to complete the square wave. Once again C1444 begins to charge through R1445 to start the second cycle. The signal produced at the collector of Q1446 has a repetition rate of about one kilohertz.

The Oscillator stage can be changed by jumper P1445. When this jumper is installed in the DC position, the Oscillator is disabled and the collector of Q1446 rises positive. This produces a positive dc voltage output to the front-panel Calibrator pin-jacks.

OUTPUT AMPLIFIER

Transistors Q1450 and Q1453 are connected as a comparator with the reference level at the base of Q1453 determined by the network R1455-R1456-R1457-R1459. The 4 Volts adjustment R1459, is set to provide accurate output voltage at the 4 V Calibrator pin-jack.

The output of the Oscillator stage is connected to the base of Q1450. This signal controls the conduction of comparator Q1450-Q1453. When the base of Q1450 is high, it is off, and Q1453 is conducting. This produces a positive output voltage at the Calibrator pin-jacks. When the level at the base of Q1450 is switched low, Q1450 conducts and Q1453 is reverse biased. Now, the voltage level at the Calibrator pin-jacks drops to zero.

(A)

Theory of Operation-7623A/R7623A Service

OUTPUT VOLTAGE DIVIDER

The collector current of 01453 in the Output Amplifier stage is applied across the voltage divider made up of resistors R1461 through R1467. This divider is designed to provide a low output resistance in the 40 mV and 0.4 V position while providing accurate output voltages. The output resistance at the 4 V pin-jack is about 450 ohms and at the 0.4 V and 40 mV pin-jacks is about 50 ohms.

READOUT SYSTEM <9> (Option 1 Deletes the Readout System)

INTRODUCTION

The 7000-series Readout System provides alpha-numeric display of information encoded by the plug in units. This display is presented on the crt and is written by the crt beam on a time-shared basis with the analog waveform display.

The definition of several terms follows'

Character-A character is a single number, letter, or symbol displayed on the crt, either alone or in combination with other characters

Word-A word is made up of a related group of characters. In the Readout System, a word can consist of up to ten characters

Frame-A frame is a display of all words for a given operating mode and plug-in combination. Up to ten character words (six words in 3-compartment mainframes) can be displayed in one frame. Figure 3-24 shows the position of each word in a complete frame.

Column-One of the vertical lines in the Character Selection Matrix (see Figure 3-25) Columns R-10 (row 10) and R-14 (row 14) can be addressed in the Readout System.

Time-Slot-A location in a pulse train. In the Readout System, the pulse train consists of 10 negative-going pulses. Each time-slot pulse is assigned a number between one and ten. For example, the first time-slot is TS-1

Time-multiplexing-Transmission of data from two or more sources over a common path by using different time intervals for different signals

THREE-COMPARTMENT MAINFRAMES

The 7000-series Readout System is compatible with both three- and four-compartment mainframes. However, since three-compartment mainframes do not have a B horizontal plug-in compartment, the B horizontal channels are not used. In these instruments a "Jump" Command is encoded for this compartment.

In three-compartment mainframes a "Jump" Command is encoded in time-slot one on the Main Interface for both channels (one and two) of the B horizontal readout. (See Word Trigger for a discussion of the "Jump" Command.) The "Jump" Command (row 13 current) is applied to pins 16 and 15 (B horizontal channels 1 and 2 respectively) of U2180. Column data current is not required for a "Jump" Command. This allows the Readout System to sense a "jump" during time-slot one at Channel 2, which causes it to "jump" the remaining nine time slots for that channel and go to Channel 1 where it again senses a "Jump" Command during time-slot one. This permits it to "Jump" the remaining nine time slots in Channel 1. The Readout System then begins a new frame.

(A)

DISPLAY FORMAT

Up to eight words (six words in three compartment mainframes) of readout Information can be displayed on the crt. The position of each word is fixed and is directly related to the plug-in unit from which it originated. Figure 3-24 shows the area of the graticule where the readout from each plug-in unit is displayed. Notice that Channel 1 of each plug-in unit is displayed within the top division of the crt and Channel 2 is displayed directly below within the bottom division. Figure 3-26 shows a typical display where only Channel 2 of the Right Vertical and the Horizontal units is selected for display.

Each word in the readout display can contain up to 10 characters, although the typical display will contain between two and seven characters per word. The characters are selected from the Character Selection Matrix shown in Figure 3-25. In addition, 12 operational addresses are provided for special Instructions to the Readout System. The unused locations in the Matrix (shaded area) are available for future expansion of the Readout System. The method of addressing the locations in the Character Selection Matrix is described in the following discussion.

DEVELOPING THE DISPLAY

The following basic description of the Readout System uses the block diagram shown in Figure 3-27. This description is intended to relate the basic function of each stage to the operation of the overall Readout System. Detailed information on circuit operation is given later.

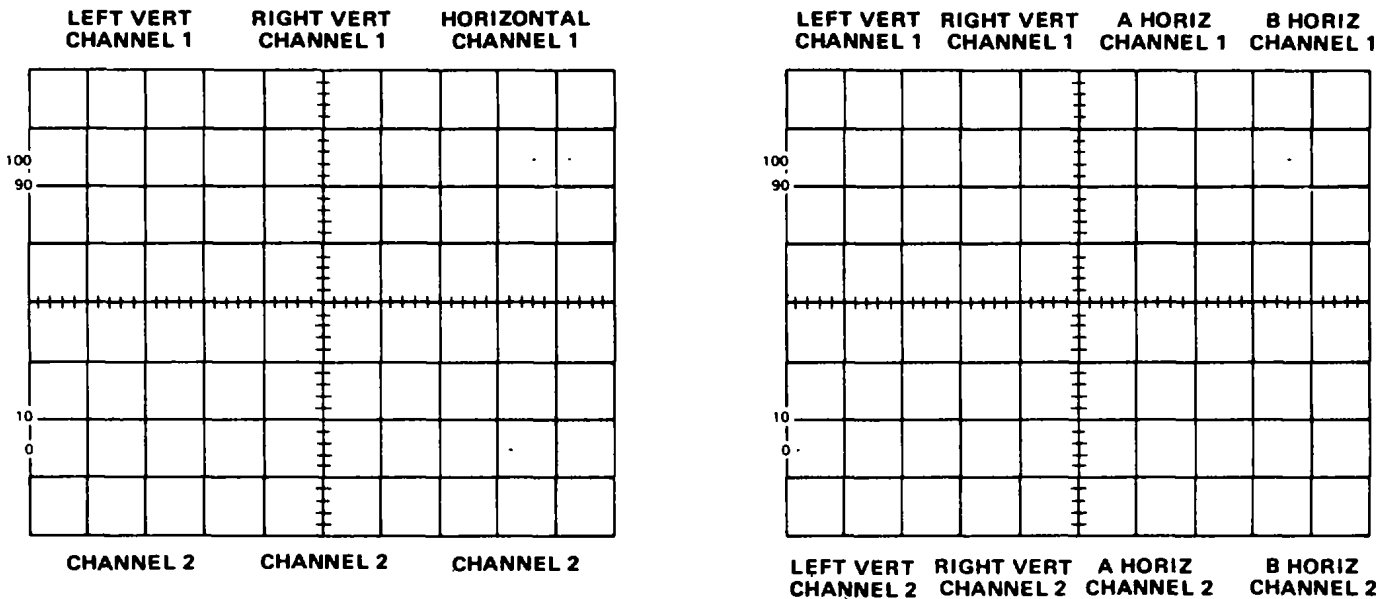

Figure 3-24. Location of readout words on the crt identifying the originating plug-in unit and channel (one complete frame shown).

Theory of Operation-7623A/R7623A Service

The key block in the Readout System is the Timer stage. This stage produces the basic signals which establish the timing sequences within the Readout System. Period of the timing signal is about 250 micro-seconds (drops to about 210 microseconds when Display-Skip Is received; see detailed description of Timing stage for further information). This stage also produces control signals for other stages within this circuit and Interrupt signals to the Vertical Amplifier, Horizontal Amplifier, and Logic circuits, which allow a readout display to be presented. The Time-Slot Counter stage receives a trapezoidal voltage signal from the Timer stage and directs it to one of ten output lines. These output lines are labeled TS-1 through TS-10 (time-slots one through ten) and are connected to the vertical and horizontal plug-in compartments as well as to various stages within the Readout System. The output lines are energized sequentially, so there is a pulse on only one of the 10 lines during any 250-microsecond timing period. After the Time-Slot Counter stage has counted time-slot 10, it produces an End-of-Word pulse which advances the system to the next channel.

Two output lines, row and column, are connected from each channel of the plug-in unit back to the Readout System. Data is typically encoded on these output lines by connecting resistors between them and the time-slot input lines. The resultant output is a sequence of ten analog current levels which range from zero to one milliamperere (100 microamperes/step) on the row and column output lines. This row and column correspond to the row and column of the Character Selection Matrix in Figure 3-25. The standard format for encoding information onto the output lines is given in Table 3-2. (Special-purpose plug-in units may have their own format for readout, these special formats will be defined in the manuals for these units.)

Table 3-2.

Standard Readout Format

Time-Slot Number	Description
TS-1	Determines decimal magnitude (number of zeros displayed or prefix change information) or the IDENTIFY function (no display during this time-slot).
TS-2	Indicates normal or inverted input (no display for normal).
TS-3	Indicates calibrated or uncalibrated condition of plug-in variable control (no display for calibrated condition).
TS-4	Scaling
TS-5	Not encoded by plug-in unit. Left blank to allow addition of zeros by Readout System.
TS-6	
TS-7	
TS-8	Defines the prefix which modifies the units of measurement.
TS-9	Define the units of measurement of the plug-in unit. May be standard units of measurement (V, A, S, etc.) or special units selected from the Character Selection Matrix.
TS-10	

The encoded column and row data from the plug-in units is selected by the Column Data Switch and Row Data Switch stages respectively. These stages take the analog currents from the eight data lines (two channels from each of the four plug-in compartments) and produce a time-multiplexed analog voltage output containing all of the column or row information from the plug-ins. The Column Data Switch and Row Data Switch are sequenced by the binary Channel Address Code from the Channel Counter

(A)

COLUMN NUMBER		C-0	C-1	C-2	C-3	C-4	C-5	C-6	C-7	C-8	C-9	C-10		
ROW NUMBER	CURRENT (MILLI-AMPERES)	0	01	02	03	04	05	06	07	08	09	> 10		
R-1	0	SKIP' ↑ ↓	0	1	2	3	4	5	6	7	8	9		
R-2	0.1		f	<	I	/	+	-	+	C	Δ	>		
R-3	0.2		ADD' ONE ZERO	ADD' TWO ZEROS	SHIFT' PREFIX ←	SHIFT' PREFIX ← AND ADD ONE ZERO						IDENTIFY'		
R-4	03		m	μ	n	p	X	K	M	G	T	R		
R-5	04		S	V	A	W	H	d	B	c	Ω	E		
R-6	05		U	N	L	Z	Y	P	F	J	Q	D		
R-7	06							DECIMAL' POINT LOCATION NO 3	DECIMAL' POINT LOCATION NO 4	DECIMAL' POINT LOCATION NO 5	DECIMAL' POINT LOCATION NO 6	DECIMAL' POINT LOCATION NO 7		
R-8	07													
R-9	08													
R-10	09		ADD SPACE IN DISPLAY'											

Figure 3-25. Character Selection Matrix for Readout System.

Theory of Operation-7623A/R7623A Service

The time-multiplexed output of the Column Data Switch is monitored by the Display-Skip Generator to determine if it represents valid information that should be displayed. Whenever information is not encoded in a time-slot, the Display-Skip Generator produces an output level to prevent the Timer stage from producing the control signals that normally interrupt the crt display and present a character.

The analog outputs of the Column Data Switch and Row Data Switch are connected to the Column Decoder and Row Decoder stages respectively. These stages sense the magnitude of the analog voltage input and produce an output current on one of ten lines. The outputs of the Column Decoder stage are identified as C-1 through C-10 (column 1 through 10)

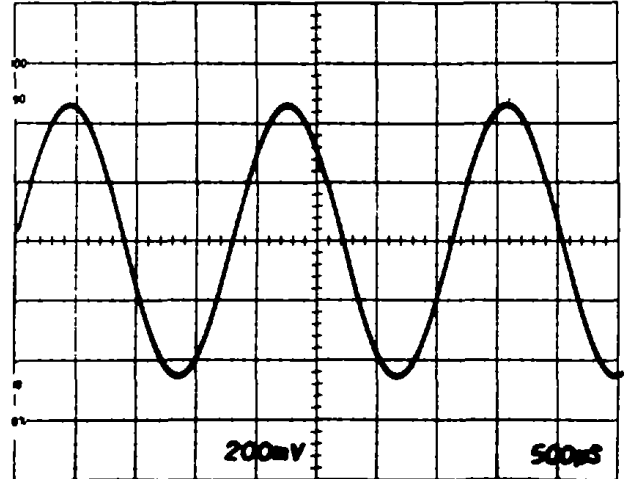

Figure 3-26. Typical readout display where only channel 2 of the Tight Vertical and Horizontal units is displayed.

corresponding to the encoded column information. Likewise, the outputs of the Row Decoder stage are identified as R-1 through R-10 (row 1 through 10) corresponding to the encoded row information. The primary function of the row and column outputs is to select a character from the Character Selection Matrix to be produced by the Character Generator stage. These outputs are also used at other points within the system to indicate when certain information has been encoded. One such stage is the Zeros Logic and Memory. During time-slot 1 (TS-1), this stage checks if zero-adding or prefix-shifting information has been encoded by the plug-in unit, and stores it in memory until time-slots 5, 6, or 8. After storing this information, it triggers the Display-Skip Generator stage so that there is no display during time-slot 1 (as defined by Standard Readout Format; see Table 3-2). When time-slots 5, 6, and 8 occur, the memory is addressed and any information stored there during time-slot 1 is transferred to the input of the Column Decoder stage to modify the analog data during the applicable time-slot.

Also, the Zeros Logic and Memory stage produces the IDENTIFY function. When time-slot 1 is encoded for IDENTIFY (column 10, row 3), this stage produces an output level, which connects the Column Data Switch and Row Data Switch to a coding network within the Readout System. Then, during time-slots 2 through 9, an analog current output is produced from the Column Data Switch and Row Data Switch which addresses the correct points in the Character Selection Matrix to display the word "IDENTIFY" on the crt. The Zeros Logic and Memory stage is reset after each word by the Word Trigger pulse.

The Character Generator stages produce the characters which are displayed on the crt. Any of the 50 characters shown on the Character Selection Matrix of Figure 3-25 can be addressed by proper selection of the column and row currents. Only one character is addressable in any one time-slot, a space can be added into the displayed word by the Decimal Point Logic and Character Position Counter stage when encoded by the plug-in. The latter stage counts the number of characters generated and produces an output current to step the display one character position to the right for each character. In addition, the character position is advanced once during each of time-slots 1, 2, and 3, whether a character is generated during these time-slots or not. This action fixes the starting point of the standard-format display such that the first digit of the scaling factor always starts at the same point within each

(A)

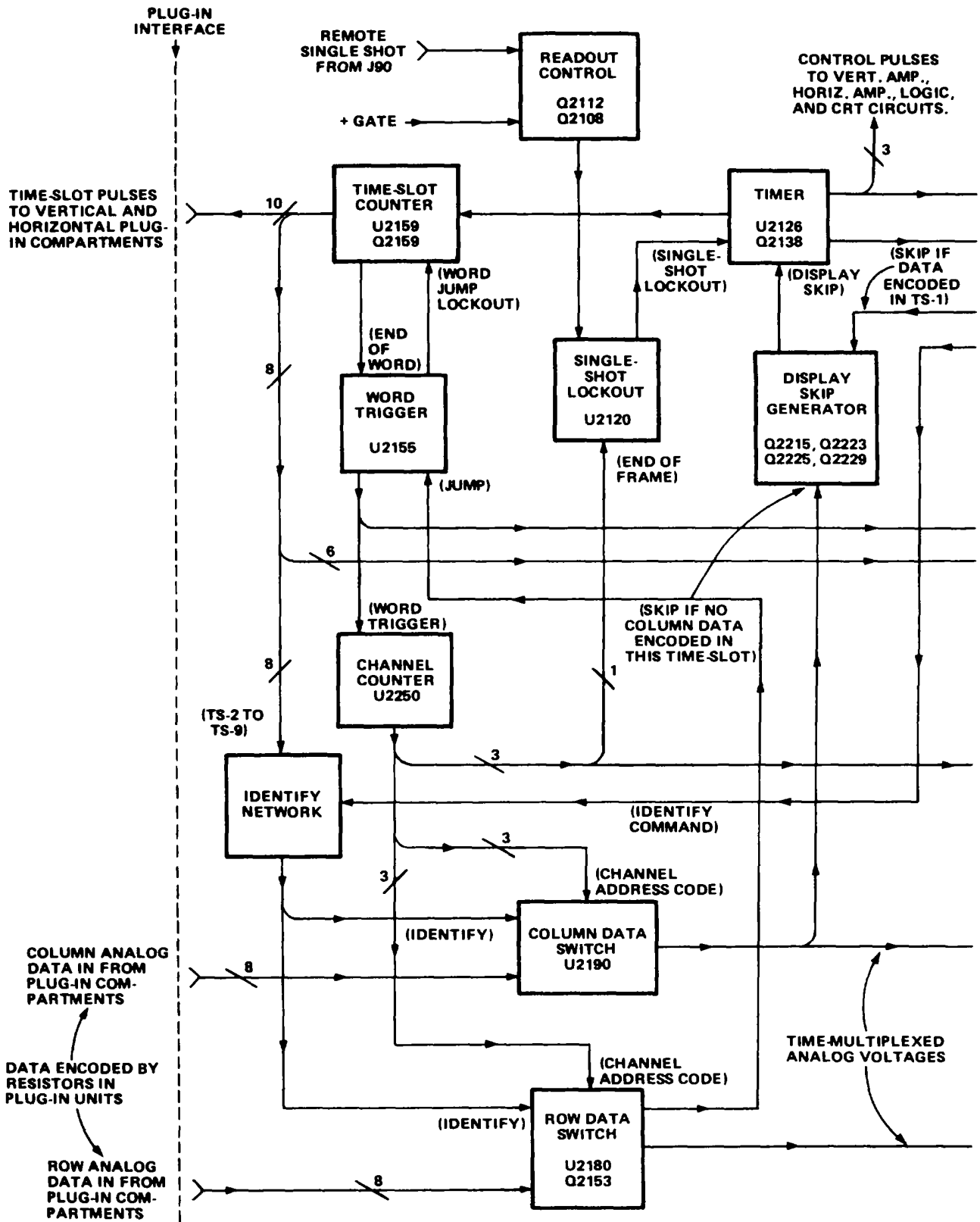

Figure 3-27. Detailed block diagram of the Readout System.

(A)

NOTE: INDICATES NUMBER OF LINES.

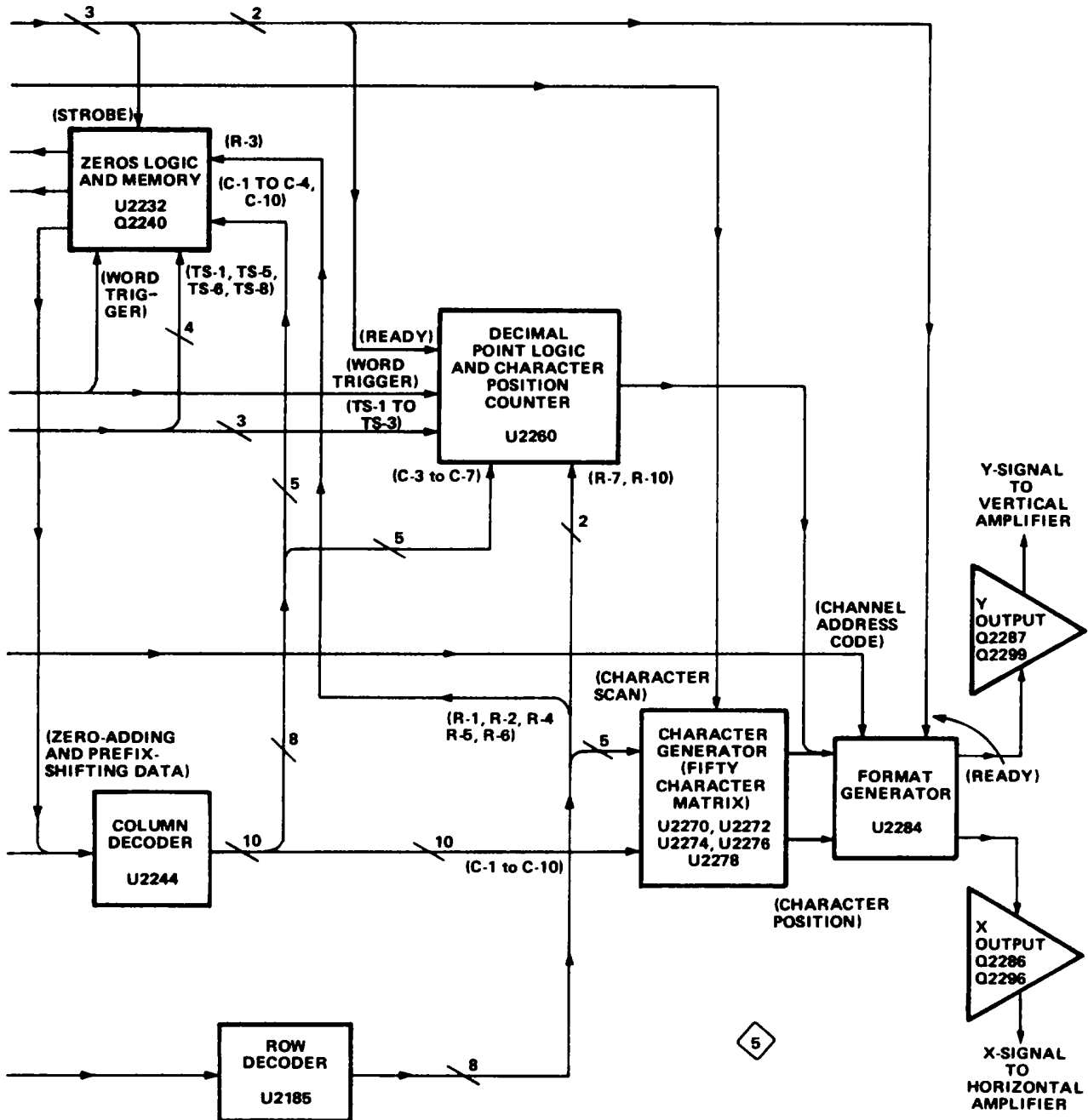
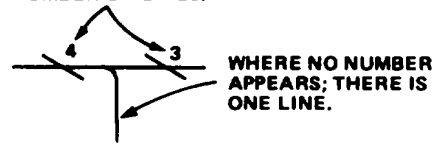

Figure 3-27. Detailed block diagram of the Readout System.

(A)

Theory of Operation-7623A/R7623A Service

word regardless of the Information encoded in time-slot 1, 2, or 3 preceding this digit. Also, by encoding row 10 and column 0 during any time-slot, a blank space can be added to the display. Decimal points can be added to the display at any time by addressing the appropriate row and column. (See Character Selection Matrix for location of decimal points.) The Decimal Point Logic and Character Position Counter stage is reset after each word by the Word Trigger pulse.

The Format Generator stage provides the output signals to the vertical and horizontal deflection systems of the instrument to produce the character display. The binary Channel Address Code from the Channel Counter stage is connected to this stage, so that the display from each channel is positioned to the area of the crt associated with the plug-in and channel originating the word (see Figure 3-24). The positioning current or decimal point location current generated by the Decimal Point Logic and Character Position Counter stage is added to the Horizontal (X) signal at the input to the Format Generator stage to provide horizontal positioning of the characters within each word. The X- and Y-Readout signals are connected to the Horizontal Amplifier and Vertical Amplifier through the X- and Y-Buffer stages.

The Word Trigger stage produces a trigger from the End-of-Word pulse generated by the Time-Slot Counter stage after the tenth time-slot. This Word Trigger pulse advances the Channel Counter to display the information from the next channel or plug-in. It also provides a reset pulse to the Zeros Logic and Memory stage and the Decimal Point Logic and Character Position Counter stage. The Word Trigger stage can also be advanced to jump a complete word or a portion of a word when a Jump Command is received from the Row Data Switch stage. The Single-Shot Lockout stage allows the display sequence of the Readout System to be changed. Normally, the Readout System operates in a free-

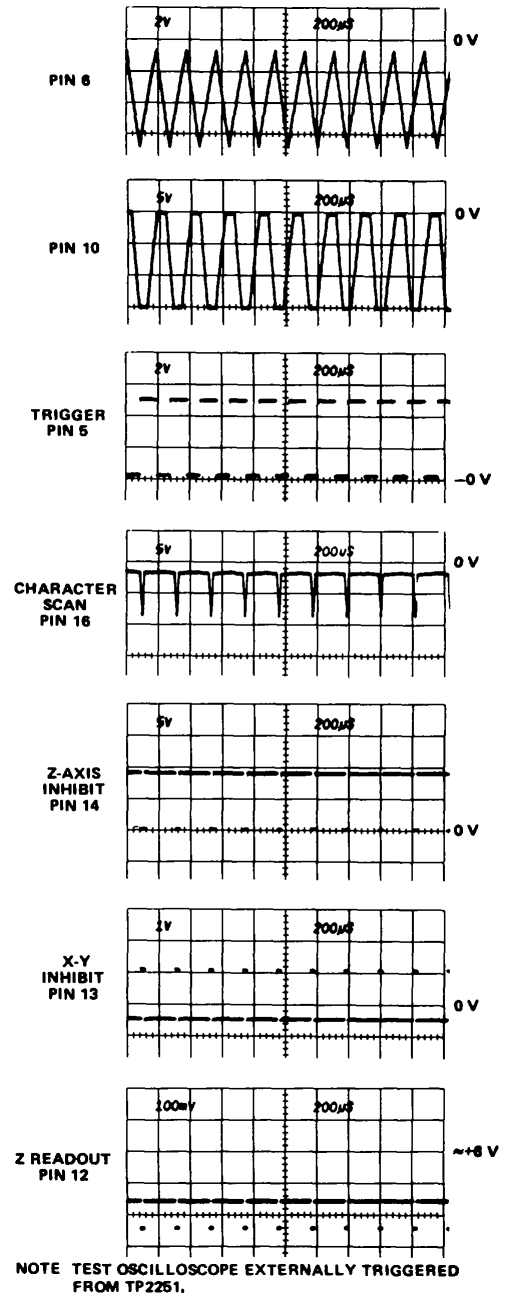

Figure 3-28. Output waveforms of Timer stage.

running mode, so the waveform display is interrupted randomly to display characters. However, under certain conditions (such as single-shot photography), it is desirable that the Readout System operate in a triggered mode where the readout portion of the display is normally blanked out, but can be presented on command. The Readout Mode switch, S2110, determines the operating mode of the Readout System.

TIMER

Timer U2126 establishes the timing sequence for all circuits within the Readout System. This stage produces seven time-related output waveforms (see Figure 3-28). The triangle waveform produced at pin 6 forms the basis for the remaining signals. The basic period of this triangle waveform is about 250 microseconds as controlled by RC network R2135-C2135. The triangle waveform is clipped and amplified by U2126 to form the trapezoidal output signal at pin 10. The amplitude of this output signal is exactly 15 volts as determined by U2126 (exact amplitude necessary to accurately encode data in plug-in units, see Encoding the Data). The Trigger output at pin 5 provides the switching signal for the Time-Slot Counter and Word Trigger stages.

The signals at pins 12, 13, 14, and 16 are produced only when the triangle waveform has reached the lower level. The timing sequence of these waveforms is important to the operation of the Readout System (see expanded waveforms in Figure 3-29). The Z-Axis Inhibit at pin 14 is produced first. This negative-going signal provides a blanking pulse to the Z-Axis Logic stage (see diagram 2) to blank the CRT before the display is switched to the Readout System. It also produces the Strobe pulse through Q2138 and CR2142 to signal other stages within the Readout System to begin the sequence necessary to produce a character. The collector level of Q2138 is also connected to Character Generator No 2, U2272 through CR2140. This activates U2272 during the quiescent period of the Strobe pulse (collector of Q2138 negative) and diverts the output current of Row Decoder U2185 to row 2. The purpose of this configuration is to prevent the Zeros Logic and Memory stage U2232 from storing incorrect data during the quiescent period of the Strobe pulse. When the Strobe pulse goes positive CR2140 is reverse-biased to disconnect Q2138 from U2272 and allow the Row Decoder to operate in the normal manner.

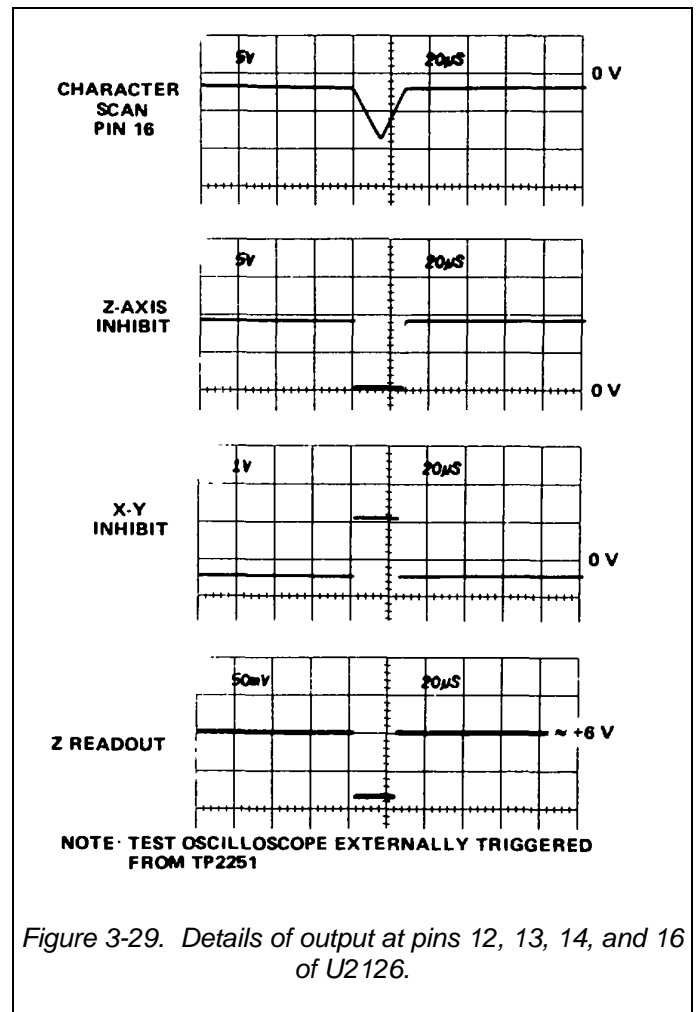

Figure 3-29. Details of output at pins 12, 13, 14, and 16 of U2126.

The next signal to be produced is the X-Y Inhibit at pin 13. This positive going signal disconnects the plug-in signals from the vertical and horizontal deflection systems.

(A)

Theory of Operation-7623A/R7623A Service

so the plug-in units do not control the position of the crt beam during the readout display. The Ready signal derived from this output is connected to the Decimal Point Logic and Character Position Counter stage and the Format Generator stage.

The Readout Intensity output at pin 12 is produced next. This current is connected to the CRT circuit to unblank the crt to the intensity level determined by the READOUT intensity control. The Character Scan ramp at pin 16 started to go negative as this timing sequence began. However, character generation does not start until the readout intensity level has been established. The triangular Character Scan ramp runs from about -2 volts to about -8.5 volts, then returns back to the original level. This waveform provides the scanning signal for the Character Generator stages. Character Scan adjustment R2128 sets the dc level of the Character Scan ramp for complete characters on the display.

The Timer stage operates in one of two modes as controlled by the Display-Skip level at pin 4. The basic mode just described is a condition that does not occur unless all ten characters of each word (80 characters total) are displayed on the crt. Under typical conditions only a few characters are displayed in each word. The Display-Skip level at pin 4 determines the period of the Timer output signal. When a character is to be generated, pin 4 is LO and the circuit operates as just described. However, when a character is not to be displayed, a HI level is applied to pin 4 of U2126 through CR2125 from the Display-Skip Generator stage. This signal causes the Timer to shorten its period of operation to about 210 microseconds. The waveforms in Figure 3-30 show the operation of the Timer stage when the Display-Skip condition occurs for all positions. In a word. Notice that there is no output at pins 12, 14, and 16 under this condition. This means, the crt display is not interrupted to display characters. Also notice that the triangle waveform at pin 6 does not go as far negative, and that the negative portion of the trapezoidal waveform at pin 10 is shorter. Complete

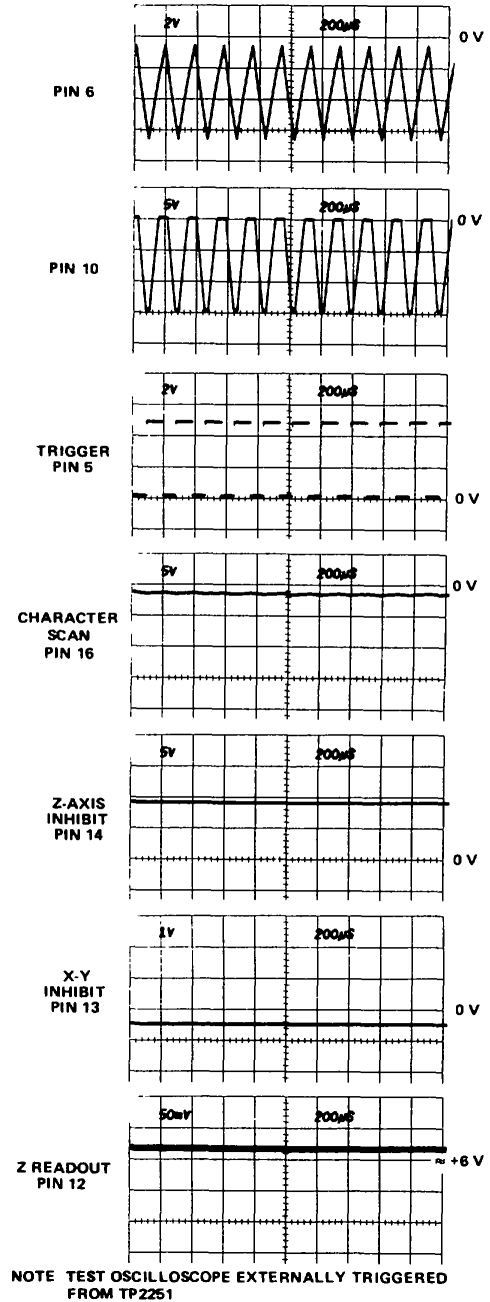

Figure 3-30. Timer stage operation when Display-Skip condition occurs.

(A)

Theory of Operation-7623A/R7623A Service

details on operation of the Display-Skip Generator are given later.

The Timer operation is also controlled by the Single-Shot Lockout level at pin 2. If this level is LO, the Timer operates as just described. However, If the Single-Shot Lockout stage sets a HI level at this pin, the Timer stage is locked out and can not produce any output signals (see Single-Shot Lockout description for further information).

READOUT intensity control R1430 sets the intensity of the readout display independently of the INTENSITY control. The READOUT intensity control also provides a means of turning the Readout System off when a readout display is not desired. When R143 is turned fully counterclockwise, the switch S1430 opens in series with the Readout Intensity line. The current to pin 11 of U2126 is interrupted, and at the same time, a positive voltage is applied to pin 4 through CR2124. The positive voltage switches the stage to the same conditions as were present under the Display Skip condition. Therefore, the crt display is not interrupted to present characters. However, time-slot pulse continue to be generated.

TIME-SLOT COUNTER

Time-Slot Counter U2159 is a sequential switch which directs the trapezoidal waveform input at pin 8 to one of its 10 output lines. These time-slot pulses are used to interrogate the plug-in units to obtain data for the Readout System. The Trigger pulse at pin 15 switches the Time-Slot Counter to the next output line; the output signal is sequenced consecutively from time-slot 1 through time-slot 10. Figure 3-31 shows the time relationship of the time-slot pulses. Notice that only one line carries a time-slot pulse at any given time. When time-slot 10 is completed, a negative-going End-of-Word pulse is produced at pin 2. The End-of-Word pulse provides a drive pulse for the Word Trigger stage and also provides an enabling level to the Display-Skip Generator during time-slot 1 only.

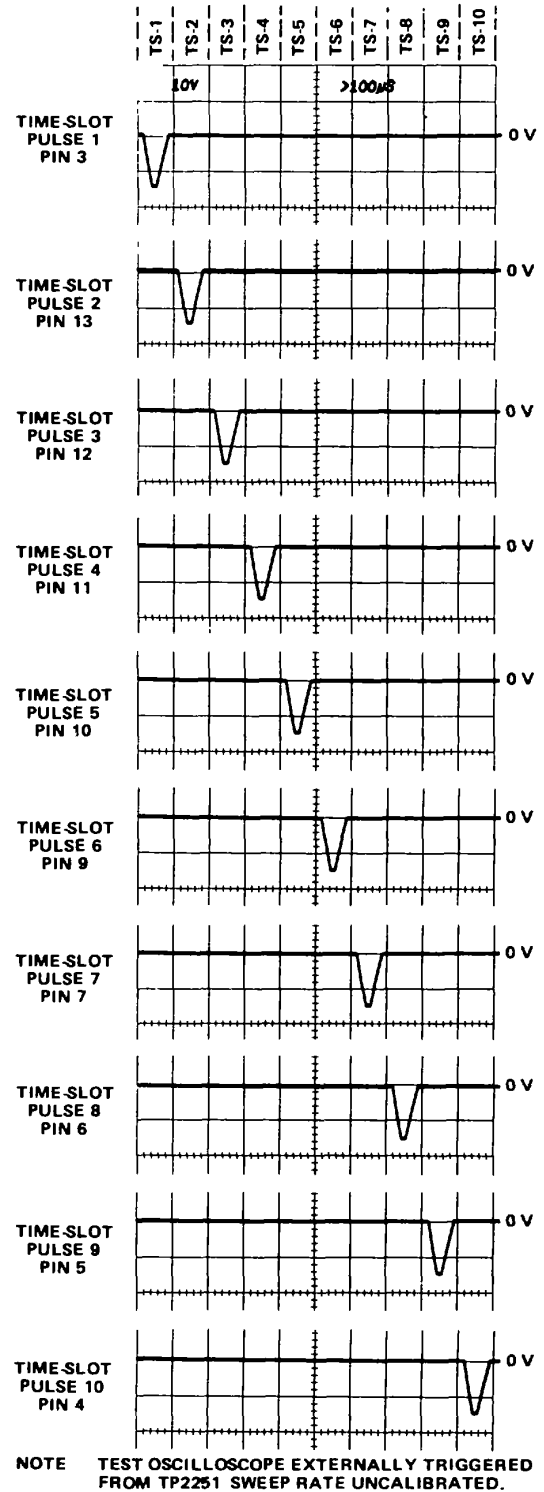

Figure 3-31. Time relationship of the time-slot (TS) pulses produced by U2159.

(A)

Theory of Operation-7623A/R7623A Service

Pin 16 is a reset Input for the Time-Slot Counter. When this pin is held LO, the Time-Slot Counter resets to time-slot 1. The Time-Slot Counter can be reset in this manner only when a Jump Command is received by U2155C (see following discussion)

WORD TRIGGER

The Word Trigger stage is made up of U2155A and B. Quiescently, pin 3 of U2155A is LO as established by the operating conditions of U2155C and D. Therefore, the LO End-of-Word pulse produced by the Time-Slot Counter results in a HI level at pin 1 of U2155A. This level is Inverted by U2155B to provide a negative-going Word Trigger pulse to the Channel Counter.

Also, a Word Trigger pulse is produced by U2155B when a Jump Command is received at pin 8 of U2155C. This condition can occur during any time-slot (see Row Decoder for further information on origin of the Jump Command). U2155C and D are connected as a bistable flip-flop. The positive going Jump Command at pin 8 of U2155C produces a LO at pin 10. This LO is inverted by U2155D to produce a HI at pin 13, which allows pin 9 to be pulled HI through CR2156. The flip-flop has now been set and remains in this condition until reset, even though the Jump Command at pin 8 returns to its LO level. The HI output level at pin 13 turns on Q2159 to pull pin 16 of the Time-Slot Counter LO. This resets the Time-Slot Counter to time-slot 1 and holds it there until the Word Trigger is reset. At the same time, a HI level is applied to pin 4 of the Timer through CR2157 and CR2125. This HI level causes the Timer to operate in the Display-Skip mode, so a character is not generated.

The next Trigger pulse is not recognized by the Time-Slot Counter, since U2159 is locked in time-slot 1 by U2155. However, this Trigger pulse resets the Word Trigger stage through C2155. Pin 13 of U2155D goes LO to enable the Time-Slot Counter and Timer stages for the next time-slot pulse. Simultaneously, when U2155D switches output states, the resulting negative-going edge is connected to pin 3 of U2155A. This results in a negative-going Word Trigger output at pin 4 to advance the Channel Counter to the next word. When the next Trigger pulse is received at pin 15, the Time-Slot Counter returns to the normal sequence of operation and produces an output on the time-slot 1 line.

CHANNEL COUNTER

Channel Counter U2250 is a binary counter which produces the Channel Address Code for the Column and Row Decoder stages and the Format Generator stage. This code instructs these stages to sequentially select and display all channels of data from the plug-ins. Table 3-3 gives the eight combinations of the Channel Address Code and the resultant channel selected with each combination.

READOUT CONTROL

Q2108 and Q2112, along with S2110, control the operating mode of the Readout System through the Single-Shot Lockout stage. When Readout Mode switch S2110 is in the Free-Run position, the Readout

(A)

TABLE 3-3.
Channel Address Code

Pin 11 U2250	Pin 8 U2250	Pin 9 U2250	Channel Displayed
LO	LO	LO	Channel 2 Left Vertical
LO	LO	HI	Channel 1 Left Vertical
LO	HI	LO	Channel 2 Right Vertical
LO	HI	HI	Channel 1 Right Vertical
HI	LO	LO	Channel 2 A Horizontal
HI	LO	HI	Channel 1 A Horizontal
HI	HI	LO	Channel 2 B Horizontal
HI	HI	HI	Channel 1 B Horizontal

System runs continuously in a free-running manner. The emitter of Q2108 has no ground return in this position, so it can not conduct. The collector of Q2108 rises positive through R2108 to enable the Read-out System.

In the Gate Trlg'd position, the emitter of Q2108 is connected to ground through R2109 and S2110 to produce a LO lockout level to the Single-Shot Lockout stage. At the end of the selected gate, a negative level is applied to the base of emitter-follower Q2112. The negative level at the emitter of Q2112 is differentiated by C2112-R2112. The resulting negative-going pulse reverse biases Q2108 to momentarily allow its collector to go HI. This enables the Single-Shot Lockout stage for a single-shot readout display. (For further information, see the following discussion.)

SINGLE-SHOT LOCKOUT

U2120 makes up the Single-Shot Lockout stage. This stage allows a single readout frame (eight complete words) to be displayed on the crt, after which the Readout System is locked out, so further readout displays are not presented until the circuit is reset. U2120B and U2120C are connected to form a bistable flip-flop. For normal operation, pin 8 of U2120C is pulled HI through R2108. This activates U2120C to result in a LO output level at pin 10, enabling the Timer stage to operate in the free-running manner described previously.

The output of the Single-Shot Lockout stage remains LO to allow U2126 to operate in the freerunning mode until a LO is received at pin 8 of U2120C. When this occurs, the output level at pin 10 of U2120C does not change immediately. However, the Readout System is now enabled as far as the single-shot lockout function is concerned.

(A)

NOTE

If the Channel Counter has not completed word eight (Channel 1 of B HORIZ unit), the Readout System continues to operate in the normal manner. However, when word eight is completed, the negative-going End-of-Frame pulse is produced at pin 11 of U2250 as the Channel Counter shifts to the code necessary to display word one. This pulse is coupled to pin 6 of U2120B. The momentary HI at pin 6 activates U2120B and its output goes LO to disable U2120C (pin 8 already LO). The output of U2120C goes HI to disable the Timer, so it operates in the Display-Skip mode. The HI at pin 10 of U2120C also holds U2120B enabled, so it maintains control of the flip-flop.

The Single-Shot Lockout stage remains in this condition until a positive-going trigger pulse is applied to pin 8 of U2120C. This trigger pulse produces a LO at pin 10 of U2120C to enable U2126 and disable U2120B. Now, the Timer can operate in the normal manner for another complete frame. When word eight is completed, the Channel Counter produces another End-of-Frame pulse to again lock out the Timer stage. (For further information on the Readout Mode, see the Readout Control description.)

ENCODING THE DATA

Data is conveyed from the plug-in units to the Readout System in the form of an analog (current level) code. The characters that can be selected by the encoded data are shown on the Character Selection Matrix (see Figure 3-25). Each character requires two currents to define it; these currents are identified as the column current and the row current, corresponding to the column and row of the matrix. The column and row data is encoded by programming the plug-in units. Figure 3-32 shows a typical encoding scheme using resistors for a voltage-sensing amplifier plug-in unit. Notice that the 10 time-slot (TS) pulses produced by the Time-Slot Counter stage are connected to the plug-in unit. However, time-slots 5, 6, 7, and 10 are not used by the plug-in unit to encode data when using the Standard Readout Format. (See Table 3-2 for Standard Readout Format.) The amplitude of the time-slot pulses is exactly -15 volts as determined by the Timer stage. Therefore, the resultant output current from the plug-in units can be accurately controlled by the programming resistors in the plug-in units.

For example, in Figure 3-32 resistors R10 through R90 control the row analog data, which is connected back to the Readout System. Figure 3-33A shows an idealized output current waveform of row analog data, which results from the time-slot pulses. Each of the row levels of current shown in these waveforms corresponds to 100 microamperes of current. The row numbers on the left-hand side of the waveform correspond to the rows in the Character Selection Matrix (see Figure 3-25). The row analog data is connected back to the Readout System via terminal B37 of the plug-in interface.

The column analog data is defined by resistors R110 through R190. The program resistors are connected to the time-slot lines by switch closures to encode the desired data. The data as encoded by the circuit shown in Figure 3-32 indicates a 100-microvolt sensitivity with the CRT display inverted and calibrated deflection factors. This results in the idealized output current waveforms shown in Figure 3-33B at the column analog data output, terminal A37 of the plug-in interface.

(A)

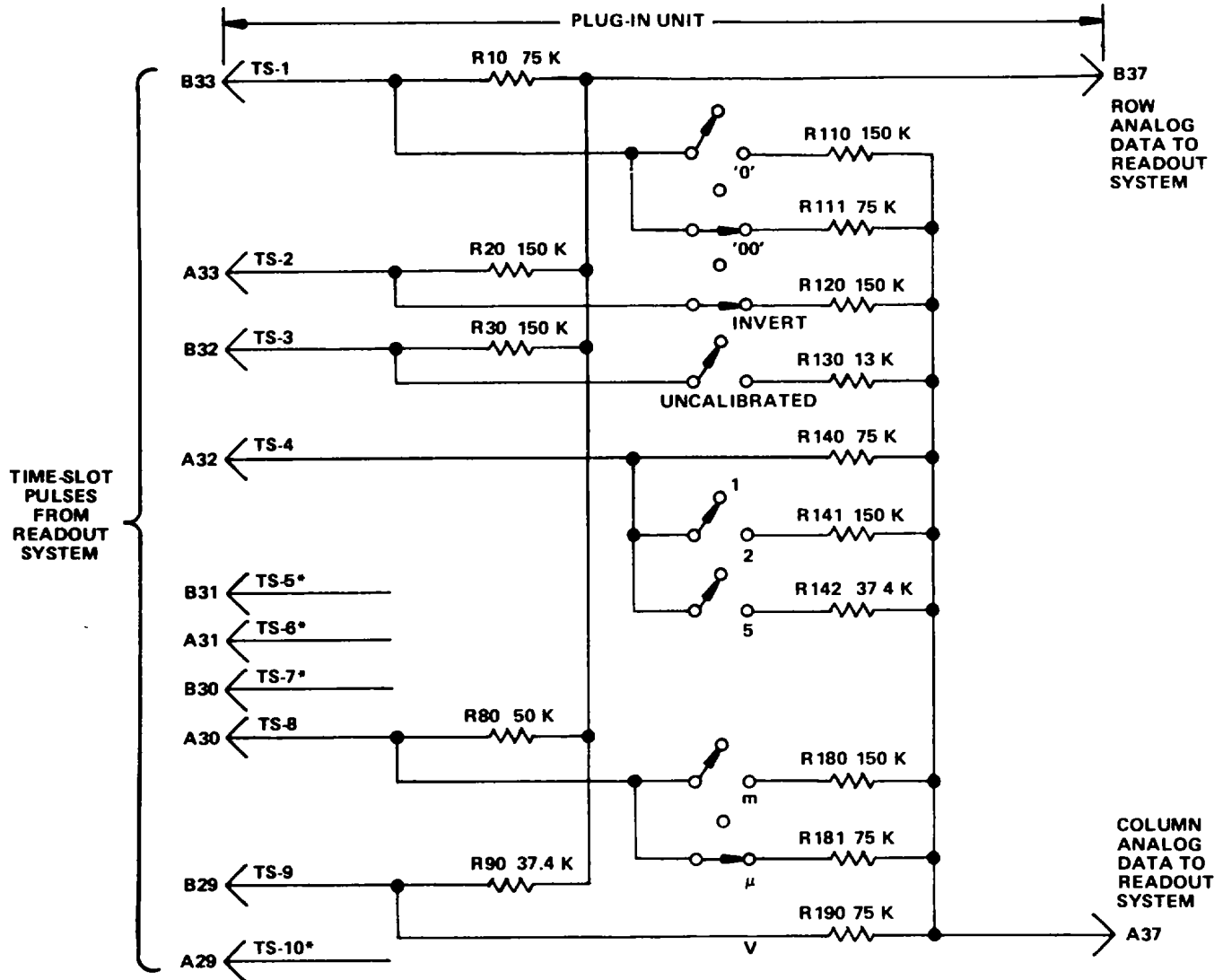

Figure 3-32. Typical encoding scheme for voltage-sensing amplifier plug-in unit Coding shown for deflection factor of 100 microvolts.

Resistor R 111, connected between time-slot 1 and the column analog data output, encodes two units of current during time-slot 1. Referring to the Character Selection Matrix, two units of column current, along with the two units of row current encoded by resistor R10 (row 3), indicates that two zeros should be added to the display. Resistor R 120 adds one unit of column current during time-slot 2 and, along with the one unit of current from the row output, the Readout System is instructed to add an invert arrow to the display. Resistor R130 is not connected to the time-slot 3 line, since the deflection factor is calibrated. Therefore, there is no column current output during this time-slot and no display on the crt. (See Display-Skip Generator for further information)

During time-slot 4, two units of column current are encoded by R 140. There is no row current encoded during this time-slot; this results in the numeral 1 being displayed on the crt. Neither row nor column analog data is encoded during time-slots 5, 6, and 7 as defined by the Standard Readout Format

(A)

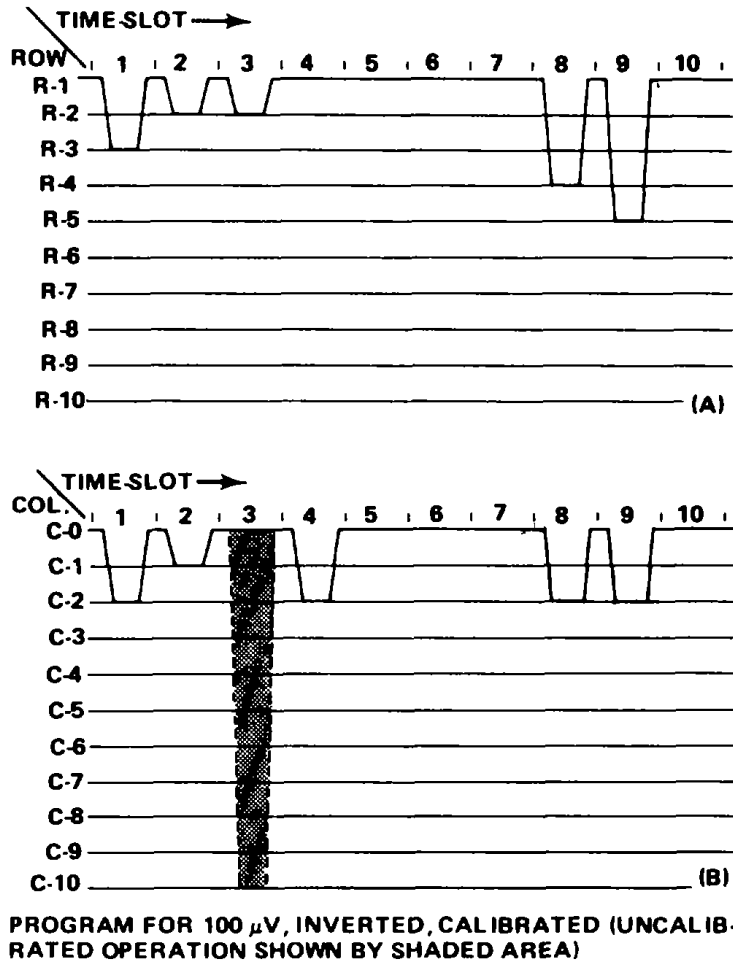

Figure 3-33. Idealized current waveforms of: (A) Row analog data, (B) Column analog data.

During time-slot 8, two units of column current and three units of row current are encoded by resistors R181 and R80, respectively. This addresses the / prefix in the Character Selection Matrix.

The final data output is provided from time-slot 9 by R 190 connected to the column output and R90 to the row output. These resistors encode three units of column current and four units of row current to cause a V (volts) to be displayed. Time-slot 10 is not encoded, in accordance with the Standard Readout Format. The resultant CRT readout will be 100 #V.

In the above example, the row analog data was programmed to define which row of the Character Selection Matrix was addressed to obtain information. In each time-slot, the column data changes to encode the applicable readout data as the operating conditions change. For example, if the variable control of the plug-in unit was activated, R130 would be connected between time-slot 3 and the column analog data output line. This encodes 10 units of column current (see shaded area in time-slot 3 of the waveform shown in Figure 3-33B). Since one unit of row current is also encoded during this time-slot by R30, a > symbol is added to the display. The CRT readout will now show I > 100 /V. In a similar manner, the other switches can change the encoded data for the column output and thereby change the readout display. See the descriptions which follow for decoding this information.

(A)

Theory of Operation-7623A/R7623A Service

The column analog data encoded by most plug-in units can be modified by attenuator probes connected to the Input connectors of amplifier plug-in units. A special coding ring around the input connector of the plug-in unit senses the attenuation ratio of the probe (with readout-coded probes only). The probe contains a circuit which provides additional column current. For example, if a 10X attenuator probe is connected to a plug-in unit encoded for 100 microvolts as shown in Figure 3-32, an additional unit of current is added to the column analog data during time-slot 1. Since two units of current were encoded by R111 (see Figure 3-32), this additional current results in a total of three units of column analog current during this time-slot. Referring to the Character Selection Matrix, three units of column current, along with the two units of row current encoded by R 10, indicates that the prefix should be shifted one column to the left. Since this instruction occurs in the same time-slot that previously indicated that two zeros should be added to the display and only one instruction can be encoded during a time-slot, the zeros do not appear in the display. The CRT readout will now be changed to 1 mV (readout program produced by plug-in same as for previous example).

Three other lines of information are connected from the plug-in compartments to the Readout System. The column and row analog data from Channel 2 of a dual-channel plug-in are connected to the Readout System through terminals A38 and B38 of the plug-in interface, respectively. Force Readout information is encoded on terminal A35, the function of this input is described under Column and Row Data Switches.

The preceding information gave a typical example of encoding data from an amplifier plug-in unit. Specific encoding data and circuitry is shown in the individual plug-in unit manuals.

COLUMN AND ROW DATA SWITCHES

The encoding data from the plug-in units is connected to the Column and Row Data Switch stages. A column-data line and a row-data line convey analog data from each of the eight data sources (two channels from each of the four plug-in compartments). The Column Data Switch U2190 and the Row Data Switch U2180 receive the Channel Address Code from the Channel Counter. This binary code directs the Column Data Switch and the Row Data Switch as to which channel should be the source of the encoding data. Table 3-3 gives the eight combinations of the Channel Address Code and the resultant channel selected with each combination. These stages have nine inputs and provide a time-multiplexed output at pin 7, which includes the information from all of the input channels. Eight of the nine inputs to each stage originate in the plug-in units, the ninth input comes from a special data-encoding network composed of resistors R2191 through R2199 and R2201 through R2209 (See Zeros Logic and Memory description for further information on ninth channel.)

In addition to the encoding data inputs from the plug-in units, inputs are provided to the Column Data Switch from the VERTICAL MODE and HORIZONTAL MODE switches to lock out the readout for any plug-in unit(s) not selected for display (see Diagram 1). When a plug-in unit is selected, a HI level is applied to the Lockout input for the opposite channel. The channel lockout lines are LO only

(A)

Theory of Operation-7623A/R7623A Service

when the associated plug-in unit has been selected for display. When a unit is not selected, the respective line is HI to forward bias the associated diodes. CR2162-CR2163, CR2166-CR2167, CR2170-CR2171, or CR2174-CR2175. The forward-biased diodes cause the channel switches to bypass the encoded data from the inhibited channel. However, since it may be desired to display information from special-purpose plug-in units (even though they do not produce a normal waveform display on the crt), a feature is provided to over-ride the channel lockout. This is done by applying a LO to the associated Force Readout input. The LO level diverts the HI channel-inhibit current and allows the data from this plug-in unit to reach the Column Data Switch, even though it has not been selected for display by the mode switch.

Row Match adjustment R2182 sets the gain of the Row Data Switch to match the gain of the Row Decoder for correct output. Column Match adjustment R2213 performs the same function for the Column Data Switch stage.

DISPLAY-SKIP GENERATOR

The Display-Skip Generator is made up of Q2215, Q2233, Q2225, and Q2229. This stage monitors the time-multiplexed column data at the output of the Column Data Switch during each time-slot to determine if the information at this point is valid data that should result in a crt display. Quiescently, there are about 100 microamperes of current flowing through R2213 from Q2240 and the Zeros Logic and Memory stage. (The purpose of this quiescent current will be discussed in connection with the Zeros Logic and Memory stage.) This current biases Q2215A so that its base is about 0.2 volt more positive than the base of Q2215B in the absence of column data. Therefore, since Q2215A and Q2215B are connected as a comparator, Q2215A will remain on unless its base is pulled more negative than the base of Q2215B.

The analog data output from the Column Data Switch produces a 0.5-volt (approximately) change for each unit of column current that has been encoded by the plug-in unit. Whenever any information appears at the output of the Column Data Switch, the base of Q2215A is pulled more negative than the base of Q2215B, resulting in a negative (LO) Display-Skip output to the Timer stage through Q2225. Recall that a LO was necessary at the skip input of the Timer so it could perform the complete sequence necessary to display a character.

Q2223-Q2229 also provide Display-Skip action. The End-of-Word level connected to their emitters is LO only during time-slot 1. This means they are enabled only during this time-slot. These transistors allow the Zeros Logic and Memory stage to generate a Display-Skip signal during time-slot 1 when information that is not to be displayed on the crt has been stored in memory (further information is given under Zeros Logic and Memory).

COLUMN AND ROW DECODERS

The Column Decoder U2244 and Row Decoder U2185 sense the magnitude of the analog voltages at their inputs (pin 10) and produce a binary output on one of ten lines corresponding to the column or row data encoded by the plug-in unit. These outputs provide the Column Digital Data and Row Digital Data, which is used by the Character Generator stages to select the desired character for display on the crt. The column and row data is also used throughout the Readout System to perform other functions.

(A)

Theory of Operation-7623A/R7623A Service

The input current at pin 9 of the Column Decoder stage is steered to only one of the ten Column Digital Data outputs. When a Display-Skip signal is present (collector of Q2225 HI), pin 9 is pulled HI through CR2226. This ensures that no current is connected to the Character Generator stage under this condition. Notice the corresponding input on the Row Decoder. This input is connected to ground and causes only one of the ten row outputs to saturate to ground.

The network at the input of the Row Decoder, made up of Q2153 and its associated components, is a Row-14 detector which produces the Jump Command. This row current is encoded by special-purpose plug-ins to cause all or part of a word to be jumped. Whenever row 14 (thirteen units of row current, or 1.3 milliamperes) is encoded, the base of Q2153 is pulled negative enough so that this transistor is reverse biased to produce a HI Jump Command output at its collector. The Jump Command is connected to the Word Trigger stage to advance the Channel Counter to the next word and to reset the Time-Slot Counter to time-slot 1.

ZEROS LOGIC AND MEMORY

The Zeros Logic and Memory stage U2232 stores data encoded by the plug-in units to provide zeros- adding and prefix-shifting logic for the Readout System. The Strobe pulse at pin 15 goes positive when the data has stabilized and can be inspected. This activates the Zeros Logic and Memory stage so that it can store the encoded data. A block representation of the memory sequence is shown in Figure 3-34.

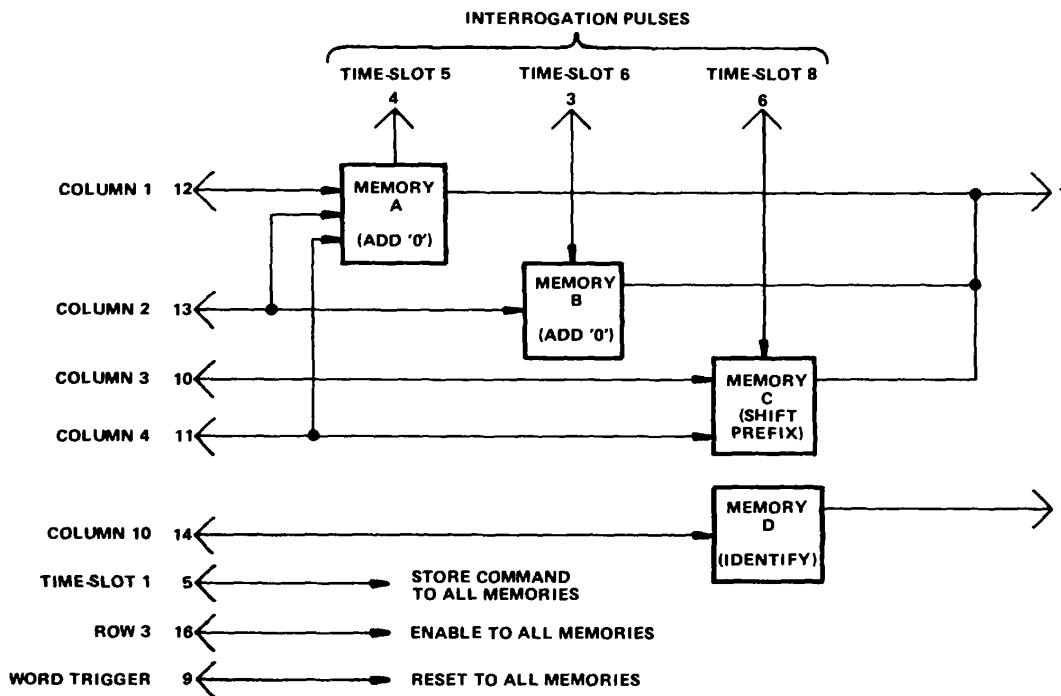

Figure 3-34. Block representation of memory sequence in U2232.

(A)

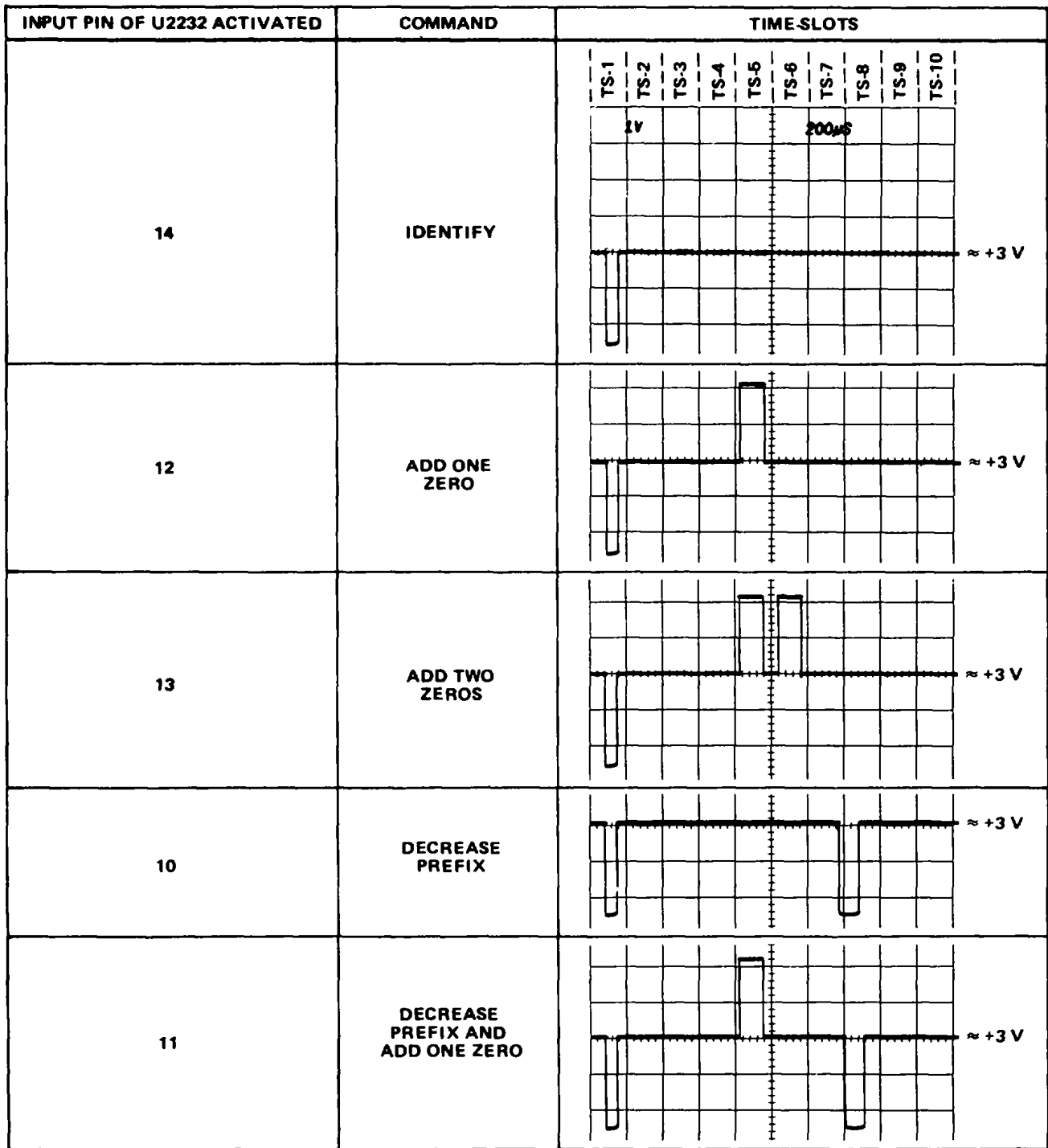

Figure 3-35. Typical output waveforms or Zeros Logic and Memory stage operation (at pin 7 of U2232).

Typical output waveforms for the five possible input conditions that can occur are shown in Fig 3-35. When time-slot 1 occurs, a store command is given to all of the memories. If the plug-in unit encoded data for column 1, 2, 3, 4, or 10 during time-slot 1, the appropriate memory (or memories) is set. Notice that row 3 information from the Row Decoder must also be present at pin 16 for data to be stored in the memory of U2232.

(A)

Theory of Operation-7623A/R7623A Service

If data was encoded during time-slot 1, a negative-going output is produced at pin 7 while the memories are being set. This negative-going pulse is connected to the base of Q2229 in the Display-Skip Generator to produce a Display-Skip output. Since the information encoded during time-slot 1 was only provided to set the memories and not intended to be displayed on the crt at this time, the Display-Skip output prevents a readout display during this time-slot.

During time-slot 5, memory A is interrogated. If information was stored in this memory, a positive-going output is produced at pin 7. This pulse is connected to pin 10 of the Column Decoder through Q2240 to add one unit of current at the Input of the Column Decoder. This produces a zero after the character displayed during time-slot 4. During time-slot 6, memory B is interrogated to see if another zero should be added. If another zero is necessary, a second positive output is produced at pin 7, which again results in a column 1 output from the Column Decoder and a second zero in the crt display.

Finally, memory C is interrogated during time-slot 8 to obtain information on whether the prefix should be changed, or left at the value that was encoded. If data has been encoded that calls for a shift in prefix, a negative-going output level is produced at pin 7. This negative level subtracts one unit of column current from the data at the input to the Column Decoder. Notice on the Character Selection Matrix of Fig.3-25 that when row 4 is programmed, a reduction of one column results in a one-column shift of the prefix. For example, with the 100 /V program shown in Fig.3-32, if the data received from the plug-in called for a shift in prefix, the crt readout would be changed to 1 mV (zeros deleted by program, see Encoding the Data).

The 100 microamperes of quiescent current through R2213 provided by Q2240 (see Display-Skip Generator) allows the prefix to be shifted from m (100 microamperes column current, column 1) to no prefix (zero column current, column zero) so only the unit of measurement encoded during time-slot 9 is displayed. Notice that reducing the prefix program from column 1 to column 0 programs the Readout System to not display a character at this readout location.

A further feature of the Zeros Logic and Memory is the Identify function. If 10 units of column current are encoded by the plug-in unit along with row 3 during time-slot 1, the Zeros Logic and Memory produces a negative-going output pulse at pin 1 to switch the Column Data Switch and Row Data Switch to the ninth channel. Then, time-slot pulses 2 through 9 encode an output current through resistors R2191- R2199 for column data and R2201-R2209 for row data. This provides the currents necessary to display the word IDENTIFY in the word position allotted to the channel that originated the Identify command. After completion of this word, the Column Data Switch and Row Data Switch continue with the next word in the sequence.

The Word Trigger signal from the Word Trigger stage is connected to pin 9 of U2232 through C2242. At the end of each word of readout information, this pulse goes LO. This erases the four memories in the Zeros Logic and Memory in preparation for the data to be received from the next channel.

(A)

Theory of Operation-7623A/R7623A Service

CHARACTER GENERATORS

The Character Generator stage consists of five similar Integrated circuits (U2270 through U2278), which generate the X (horizontal) and Y (vertical) outputs at pin 16 and 1, respectively, to produce the character display on the crt. Each integrated circuit can produce 10 individual characters. U2270 (designated 'Numerals') can produce the numerals 0 through 9 shown in row 1 of the Character Selection Matrix (Fig.3-25). U2272 can produce the symbols shown in row 2 of the Character Selection Matrix and U2274 produces the prefixes and some letters, used as prefixes, shown in row 4. U2276 and U2278 produce the remaining letters shown in rows 5 and 6 of the Character Selection Matrix.

All of the Character Generator stages receive the Column Digital Data from the Column Decoder U2244 in parallel. However, only one of the Character Generators receives row data at a particular time and only the stage receiving this row data is activated. For example, if column 2 is encoded, the five Character Generators are enabled so that either a 1, <, A, V, or an N can be produced. If row 4 has been encoded at the same time, only the Prefix Character Generator U2274 will produce an output to result in a 'p' being displayed. The activated Character Generator provides current outputs for the Format Generator to produce the selected character on the crt. In a similar manner, any of the characters shown in the Character Selection Matrix can be displayed by correct addressing of the row and column.

DECIMAL POINT LOGIC AND CHARACTER POSITION COUNTER

Decimal Point Logic and Character Position Counter U2260 performs two functions. The first function is to add a staircase current to the X (horizontal) signal to space the characters horizontally on the crt. After each character is generated, the negative-going edge of the Ready signal at pin 5 advances the Character Position Counter. This produces a current step output at pin 3 which, when added to the X signal, causes the next character to be displayed one character space to the right. This stage can also be advanced when a Space instruction is encoded so a space is left between the displayed characters on the crt. Row 10 information from the Row Decoder is connected to pin 4 of U2260. When row 10 and column 0 are encoded, the output of this stage advances one step to move the next character another space to the right. However, under this condition, no display is produced on the crt during this time-slot, since the Character Generators are not activated.

Time-slot pulses 1, 2, and 3 are also connected to pin 4 of U2260 through VR2262, VR2263, and VR2264 respectively and R2262-R2265. This configuration adds a space to the displayed word during time-slots 1, 2, and 3 even if information is not encoded for display during these time-slots. With this feature, the information displayed during time-slot 4 (scaling data) always starts in the fourth character position whether data has been displayed in the previous time-slots or not. Therefore, the resultant crt display does not shift position as normal-invert or cal-un-cal information is encoded. The Word Trigger pulse connected to pin 8 resets the Character Position Counter to the first character position at the end of each word.

The Decimal Point Logic portion of this stage allows decimal points to be added to the crt display. With the Standard Readout Format, row 7, encoded coincident with columns 3 through 7, addresses a decimal at one of the five locations identified in row 7 of the Character Selection Matrix (Fig.3-25). This instruction refers to the decimal point location in relation to the total number of characters possible in one

(A)

Theory of Operation-7623A/R7623A Service

word (see Fig.3-36).For example, column 3 encoded with row 7 during time-slot 1 places a decimal point In location No.3.As shown In Fig.3-36, this displays a decimal point after the third character that can be displayed on the crt.(The first three time-slots produce a space whether data is encoded or not, see previous

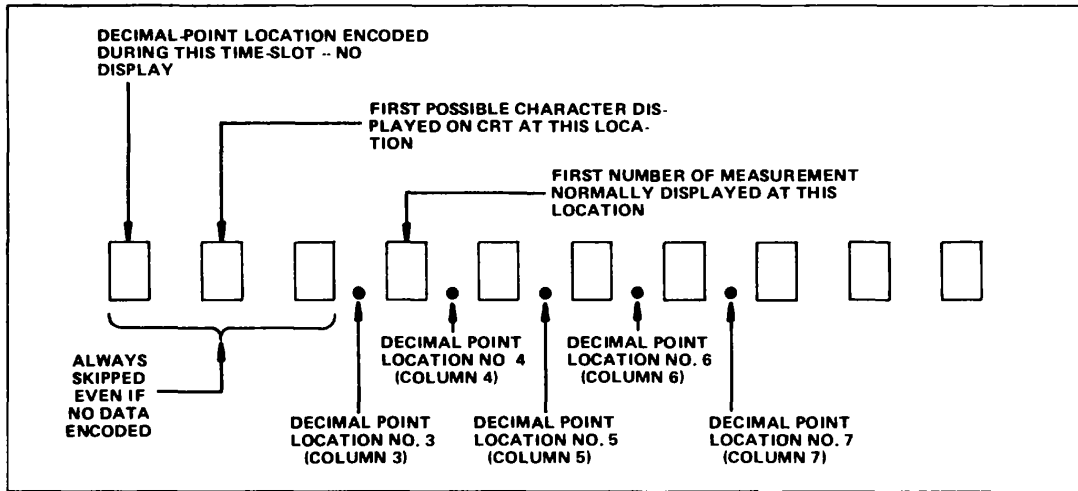

Figure 3-36. Readout word relating 10 possible character locations to the decimal point instructions that can be encoded, and the resultant crt display.

When decimal-point data is encoded, the crt is unblanked so a readout display is presented Since row 7 does not activate any of the five Character Generators, the crt beam is deflected vertically by the application of row-7 data to the Y input of the Format Generator through R2280.This places the decimal point between the characters along the bottom line of the readout word. After the decimal point is produced In the addressed location, the crt beam returns to the location indicated by the Character Position Counter to produce the remainder of the display.

FORMAT GENERATOR

The X- and Y- deflection signals produced by the Character Generator stage are connected to pins 2 and 7, respectively, of Format Generator U2284.The Channel Address Code from the Channel Counter is also connected to pins 1, 8, and 15 of this stage The Channel Address Code directs the Format Generator to add current to the X and Y signals to deflect the crt beam to the area of the crt associated with the plug-in channel that originated the information (see Fig.3-24) The Channel Address Code and the resultant word positions are shown in Table 3-3.The Ready signal at pin 13 (coincident with the X-Y Inhibit output) activates this stage when a character is to be displayed on the crt.R2274 and R2275 determine the horizontal and vertical size, respectively, of the displayed characters R2273 is the Character Height adjustment. The character position current from the Decimal Point Logic and Character Position stage is added to the X (horizontal) input signal to space the characters horizontally on the crt (see previous discussion).

(A)

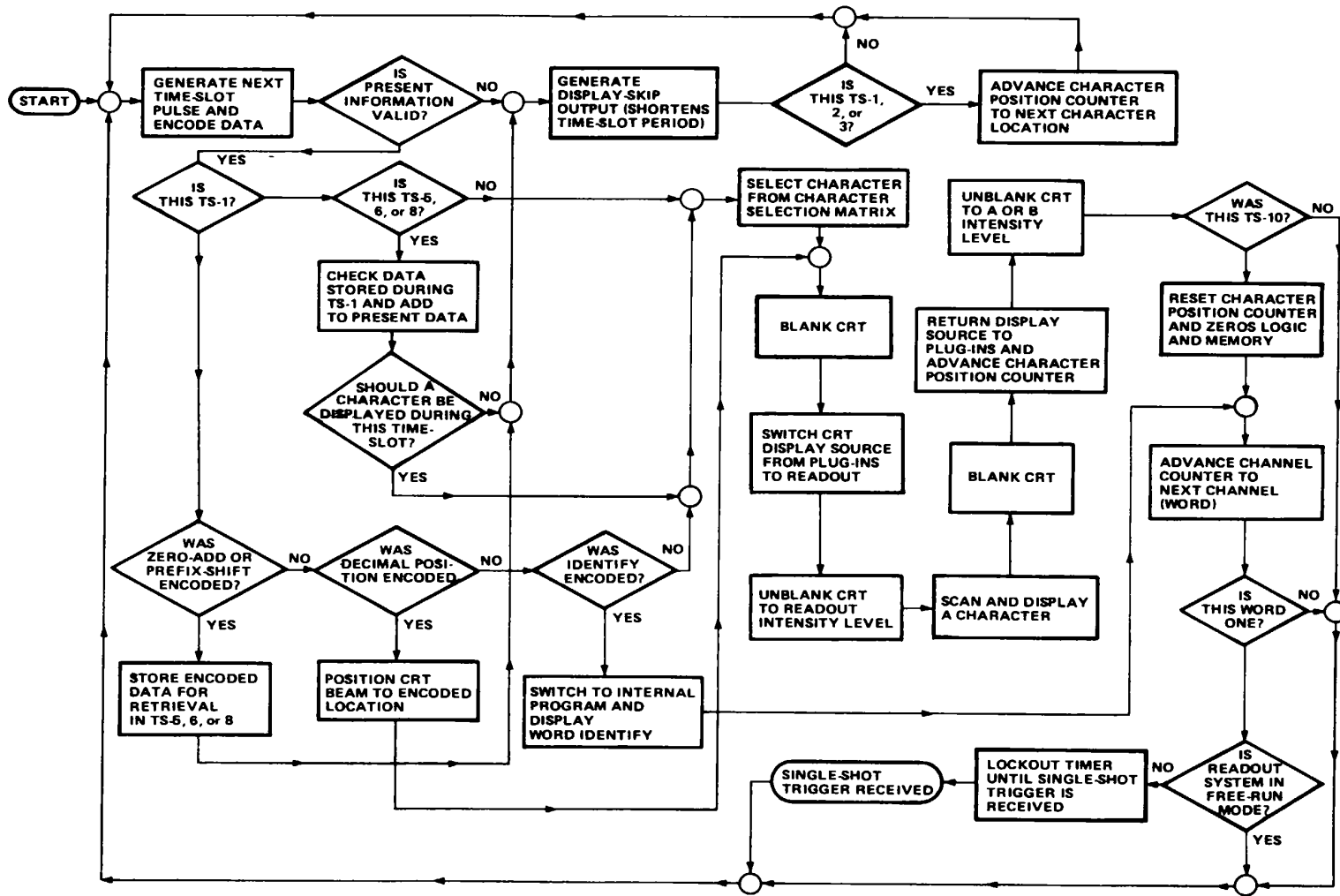

Figure 3-37. Flow chart for character generation by the Readout System.

(A)

Y-OUTPUT AMPLIFIER

The Y-output signal at pin 6 of Format Generator U2284 is connected to the Y-Output Amplifier Q2287-Q2299. This stage provides a low-impedance load for the Format Generator while providing isolation between the Readout System and the driven circuits. Vertical Separation adjustment R2291 changes the gain of this stage to control the vertical separation between the readout words displayed at the top and bottom of the graticule area.

X-OUTPUT AMPLIFIER

The X-Output Amplifier Q2286-Q2296 operates like the Y-Output Amplifier, to provide the horizontal deflection from the readout signal available at pin 4 of U2284. The gain of this stage is fixed by the values of the resistors in the circuit.

DISPLAY SEQUENCE

Figure 3-37 shows a flow chart for the Readout System. This chart illustrates the sequence of events that occurs in the Readout System each time a character is generated and displayed on the crt.

(A)

Theory of Operation-7623A/R7623A Service

STORAGE SYSTEM <10>

As shown in the simplified block diagram (Figure 3-38), the front panel controls select and operate the various pulse producing (logic) circuits. These pulses are applied to the input circuits of the operational amplifiers connected to the storage elements of the crt. The operational amplifiers, controlled by the logic pulses, provide the voltage levels necessary for operation of these storage elements. The operational amplifier output levels for the different storage modes are illustrated in Figures 3-40, 3-41, 3-42, and 3-43.

LOGIC

The timing sequence of the major logic pulses is shown in Figure 3-39. Since most timing functions begin with an erase cycle, this portion will be discussed first.

When the MANUAL ERASE push button is pressed, a positive pulse is coupled to the base of Q1539. This turns on Q1539, which turns off Q1541, allowing pin 2 of U1545A to go HI. When not in SAVE (pin 1 of U1545A is HI in SAVE), this triggers the one-shot to start the erase cycle. The erase pulse stays HI for 100 milliseconds, as determined by R1544 and C1544.

Grounding the REMOTE ERASE input couples a negative step to the cathode of CR1538, which turns off Q1541 and allows pin 2 of U1545A to go HI, starting an erase cycle.

PERIODIC ERASE is accomplished by charging C1517 to the firing voltage of Q1518 (a program-mable-unijunction transistor). When Q1518 fires, it discharges C1517 through R1519, momentarily blocking the conduction of Q1541. This too, pulses pin 2 of U1545A HI, causing it to change state and output an erase pulse. The maximum time between erase cycles is set up by C1517 and R1517. This timing is varied by the amount of current flowing through Q1513. Current through Q1513 is adjusted by the PERIODIC ERASE control, R1488B. If a sweep gate is present on the base of Q1524, the gate of Q1518 is held at approximately eight volts to prevent Q1518 from firing until after the sweep gate ends.

The erase pulse, output of U1545A at pin 13, is connected to the emitters of Q1718 and Q1697. When the erase pulse goes HI, it causes the 600-volt erase waveform (through the switching action of Q1718).

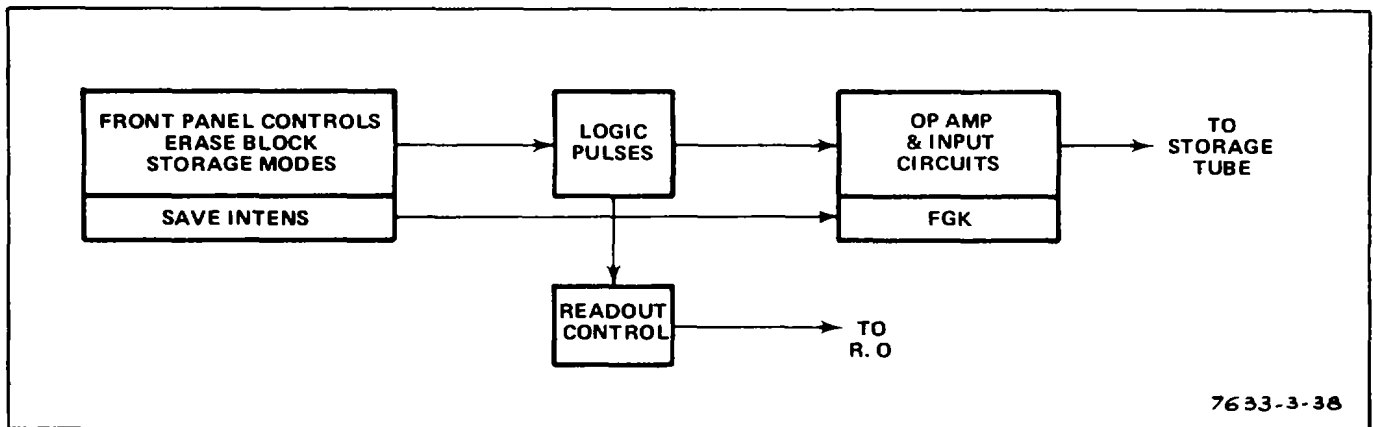

Figure 3-38. Storage circuit simplified block diagram.

(A)

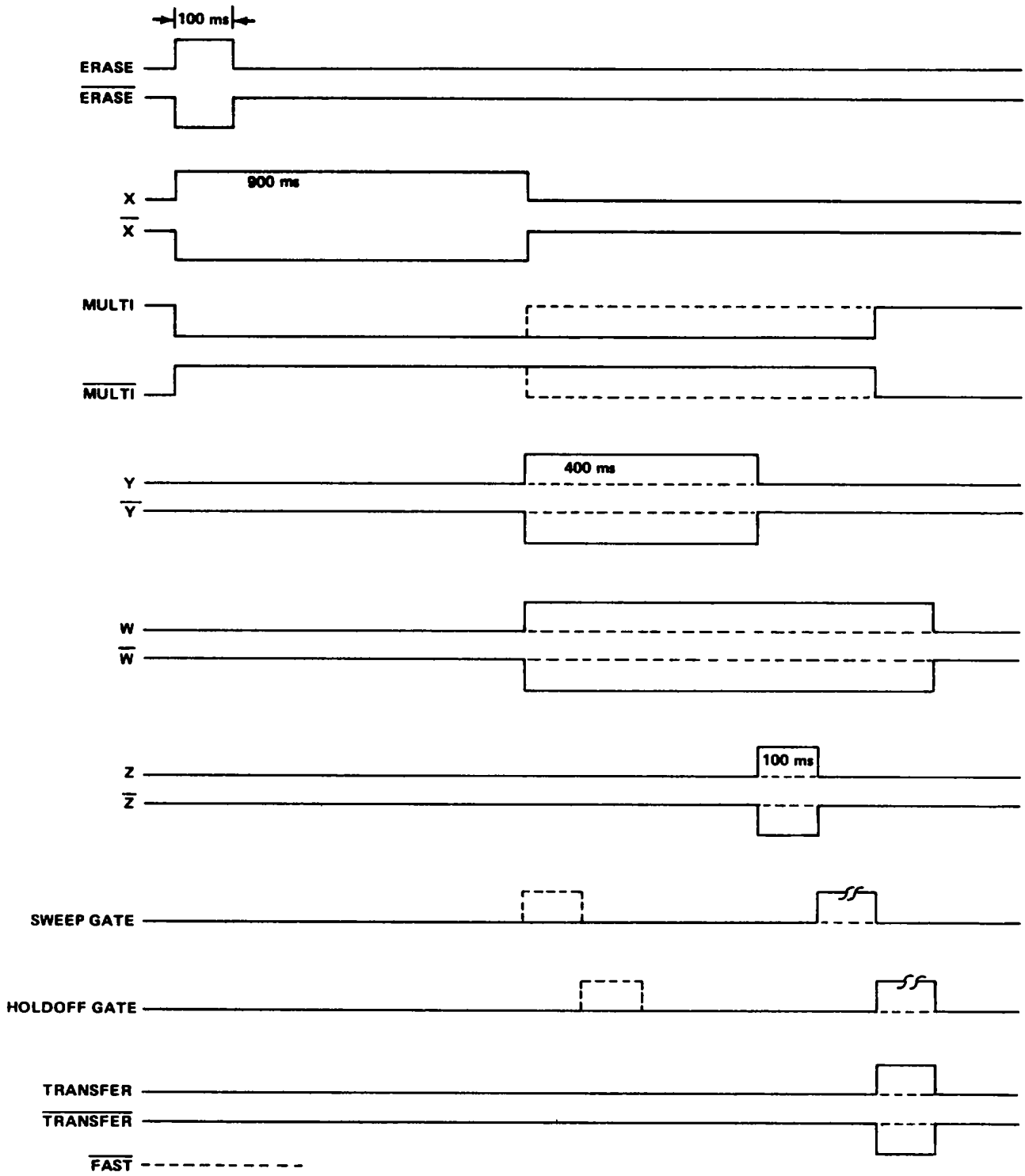

Figure 3-39. Time relationship of Storage logic pulses.

Theory of Operation-7623A/R7623A Service

then goes to -15 V and ramps up to the Bistable operation level (through the switching action of Q1697) on the Front Mesh. This waveform is shown In Figure 3-42.

When it goes HI, the erase pulse also causes Q1569 to saturate. This pulls pin 1 of U1605A LO, causing it to change state Therefore, pin 13 (the X output) of U1605A goes HI for a 600-millisecond interval The timing interval is determined by R1601 and C1601.

In the FAST mode, when the output at pin 4 (the X output) of U1605A returns to a HI logic level (after 600 milliseconds), it causes U1605B to change state. The LO on the Y output of U1605B is connected

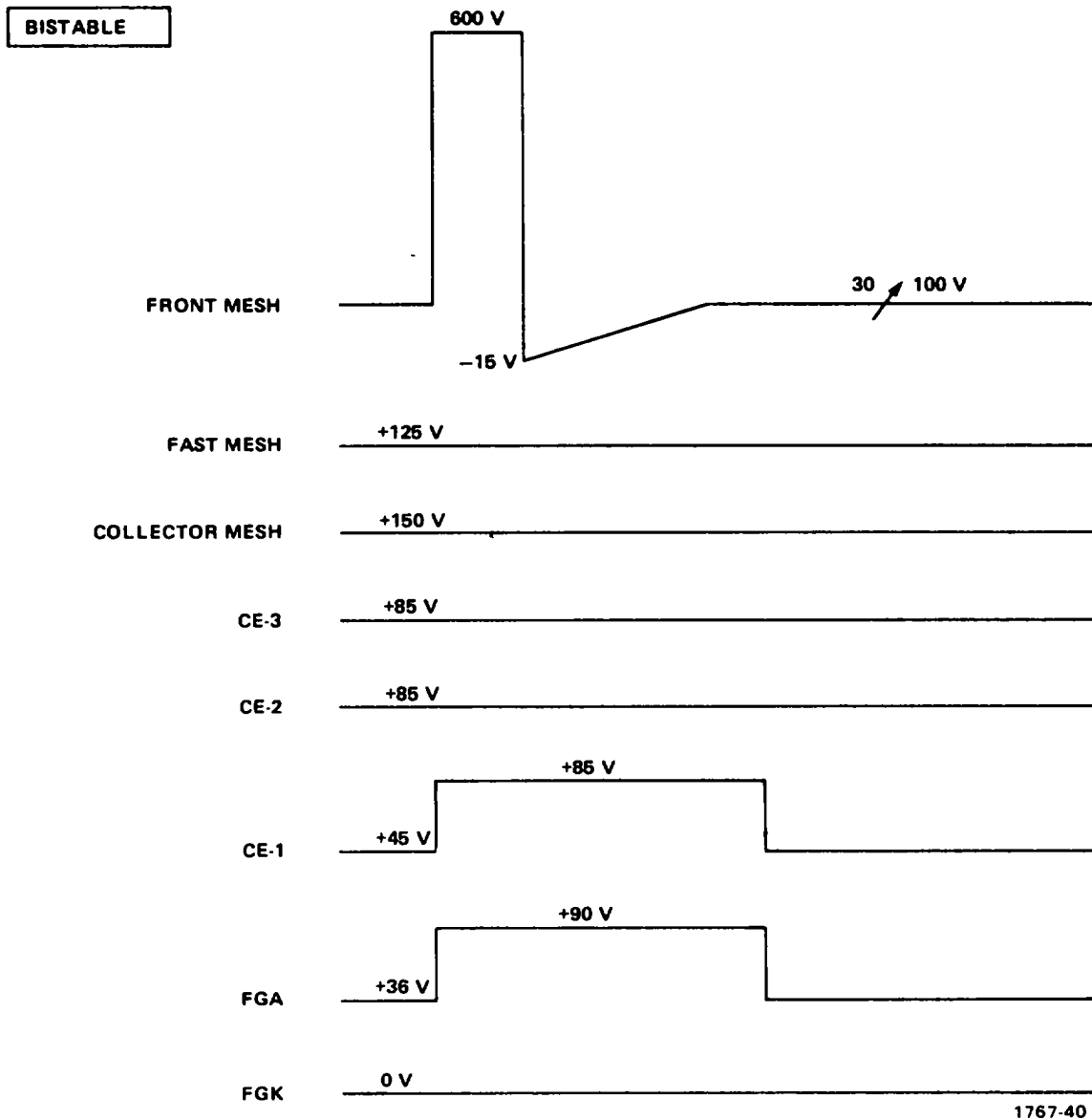

Figure 3-40. BISTABLE mode Storage waveforms.

Theory of Operation-7623A/R7623A Service

to pin 10 of U1555B, which presets the W output HI. When the Y output returns HI, after 400 milliseconds, it causes U1615B to change state. This, in turn, sets the Z output (pin 5 of U1615B) HI for 100 milliseconds.

During the time X and Y are HI, the sweep is locked out through U1495A and CR1500. During the time Z is HI, the sweep is locked out through CR1497.

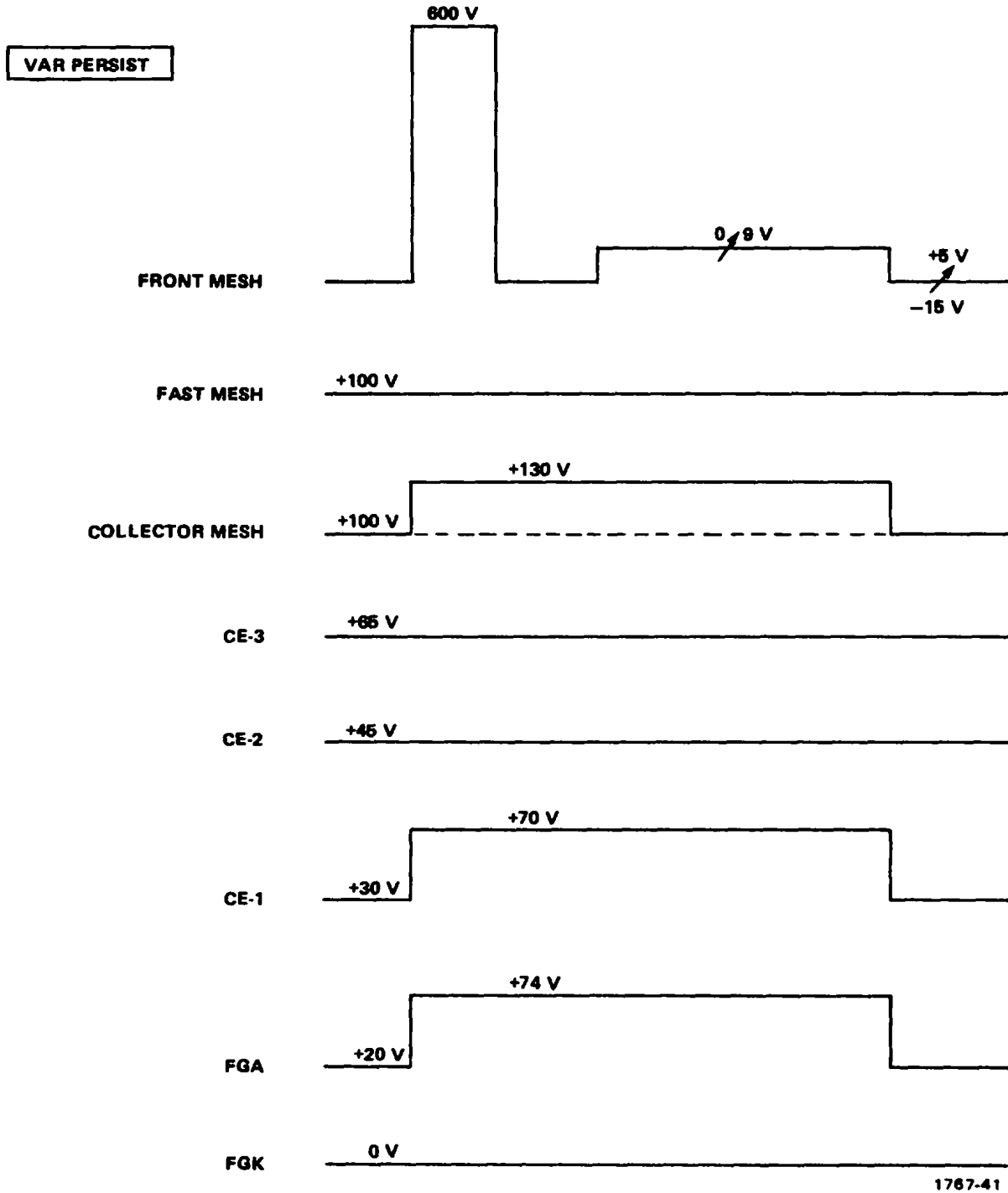

Figure 3-41. VAR PERSIST mode Storage waveforms.

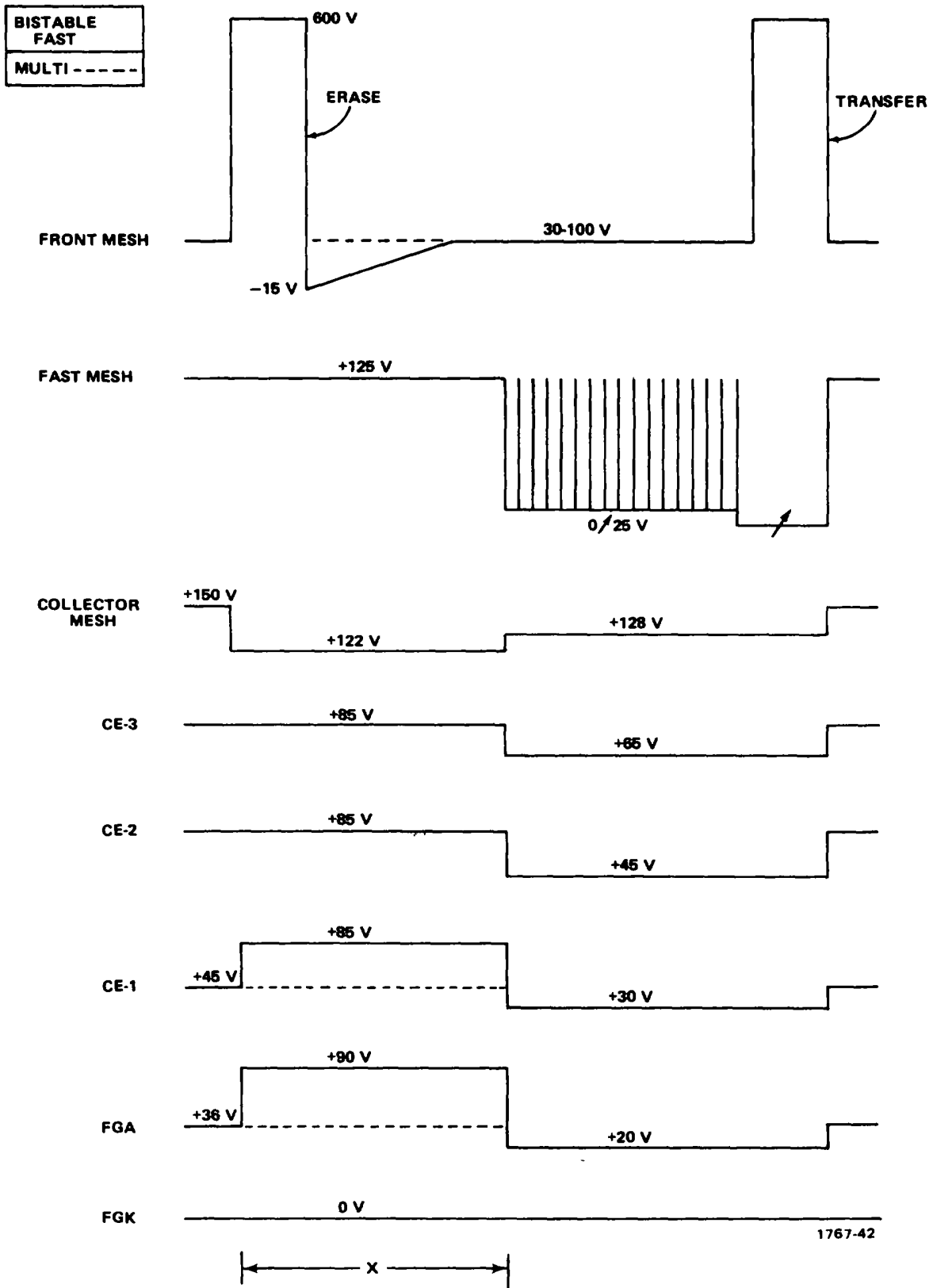

Figure 3-42. FAST BISTABLE mode Storage waveforms.

At the end of Z the sweep is free to run since it is no longer locked out. When a sweep occurs, a holdoff gate from the time-base unit indicates the end of sweep. This signal, through Q1553 and U1497B, causes U15458 to change state and output a 100-millisecond transfer pulse. At the end of transfer, when W goes LO, the sweep is locked out through CR 1496.

When $\overline{\text{TSFR}}$ returns HI after the 100-milisecond transfer pulse, it saturates Q1569 to start the timing sequence of X, Y, and Z over again. In single sweep this is prevented by the conduction of Q1564. In single sweep the sequence can only be started again by an erase pulse.

Q1587, Q1576, and Q1585 form the automatic single-sweep reset circuit. In the FAST mode, when Z returns HI after an erase pulse, it momentarily turns on Q1576, which turns off Q1587. This same signal turns on Q1585 to reset the time base. Pressing the time-base single-sweep reset button grounds the emitter of Q1587, causing it to saturate and restart the X, Y, and Z timing sequence. Since the X, Y, and Z timing sequence locks out the time base, the Z (when it goes HI) is again used to reset the time base by saturating Q1585.

When not in the FAST mode, a HI ($\overline{\text{FAST}}$) signal through R1591 to the base of Q1595 causes the clear inputs to U1605B and U1555B to be held LO, which prevents Y and W from going HI. This same HI signal keeps Q1576 saturated. This prevents Q1587 from turning on and tripping the one-shot when the time base single-sweep reset button is pressed.

Q1621 (a programmable-unijunction transistor-P.U.T.) is the clock that provides the pump pulses, the save intensity pulses, and the persistence pulses. Its gate is tied to the gate of Q1631 so the two are synchronized. Q1631 provides the 10-kHz ramp to the Front Mesh.

From the time W goes HI until sweep starts, each time a clock pulse is applied to the input of U1615A, it fires a two microsecond pump pulse into the Fast Mesh operational amplifier through Q1775 (see Figures 3-42 and 3-43). The 100-Hertz clock gives the time between pulses while the R-C network (R1614 and C1614) determines the pulse width.

OPERATIONAL AMPLIFIERS

The voltage levels on the Front Mesh are controlled by an operational amplifier composed of Q1701, Q1704, Q1708, and Q1711. Input to the operational amplifier is the base of Q1701. Feedback is provided through R1713 and C1713. The bistable level is determined by Q1686 and R1689, the variable persistence prep level by Q1667, Q1673, and R1677, and the variable persistence op level by Q1661 and R1658. Q1644 and R1646 set the Fast variable persistence waiting level (see Figure 3-43). Q1652 locks out the 10 kHz ramp and the Storage Level control in the Bistable mode and when the Prep input is HI.

When an ERASE or TSFR pulse is applied to its emitter, Q1718 saturates, turning on Q1723, which cuts off Q1728 and Q1734. This allows the +600 volts at the collector of Q1734 to be routed, through Q1743 and Q1739, to the Front Mesh as a 100-millisecond erase or transfer pulse.

(A)

Theory of Operation-7623A/R7623A

At the same time the 600-volt erase pulse is applied to the Front Mesh In the Bistable mode, the HI, ERASE logic level at its emitter causes Q1697 to saturate, discharging C1695. At the instant the erase pulse is over, Q1697 turns off and C1695 begins to charge back from ground towards -30 V. At the -15 V level, the base and collector of Q1692 approach unity, preventing any further charging of Q1695. This ramp causes the output of the operational amplifier to ramp from -15 V to the bistable operation amplifier level.

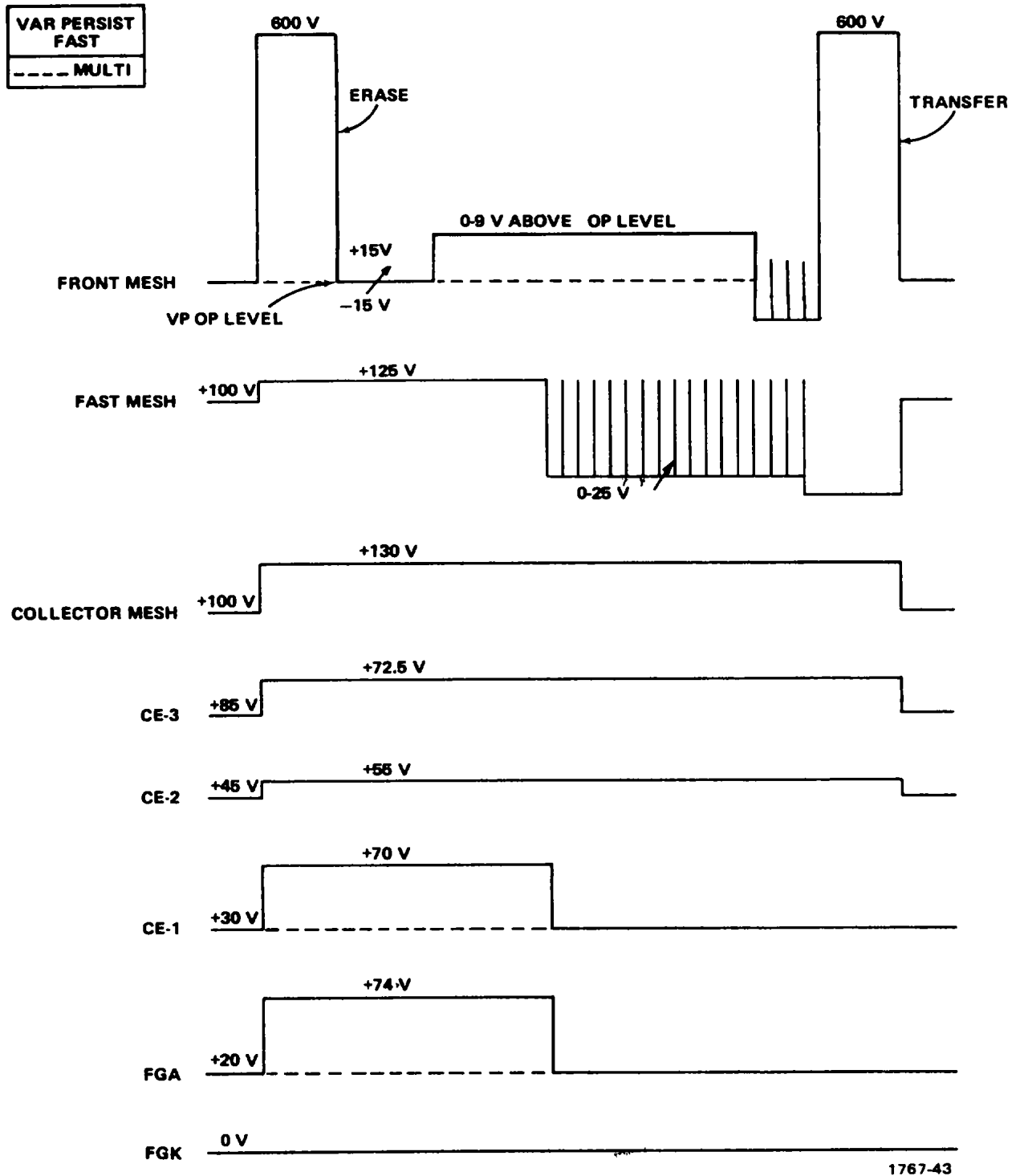

Figure 3-43. FAST VAR PERSIST mode Storage waveforms.

REV. B, JAN.1975

The operational amplifier, consisting of Q1788, Q1790, Q1795, and Q01798, connected to the Fast Mesh is essentially the same as that connected to the Front Mesh except for a smaller feedback resistor (R1792) and no feedback capacitor.

The 100 and 125 volt levels on the Fast Mesh are set by the current through CR1771. When the W logic pulse goes HI, the Fast Mesh voltage level drops and pump pulses are applied through 01775. When the SWP +TSFR logic pulse goes LO, it turns off Q1761, which lowers the Fast Mesh level further, and, by clearing U1615A, stops the pump pulses.

Voltage levels on the Collector Mesh, CE3, CE2, CE1, and FGA are set in similar manner to those on the Front and Fast Meshes by logic pulses applied to the inputs of their respective operational amplifiers.

(A)

MAINTENANCE

This section of the manual contains maintenance information for use in preventive maintenance, corrective maintenance, or troubleshooting of the 7623A/R7623A.

PRELIMINARY INFORMATION

PANEL REMOVAL

Panels and covers on both the 7623A and the R7623A should be removed in accordance with the procedures outlined below.

WARNING

Dangerous potentials exist at several points throughout this instrument. When the instrument is operated with the covers removed, do not touch exposed connections or components. Some transistors have voltages present on their cases. Disconnect power before cleaning the instrument or replacing parts.

CABINET MODEL

The side panels of the 7623A are held in place with slotted fasteners and by spring-action of the panels themselves. To remove the panels, turn each fastener counterclockwise a quarter turn with a large coin or screwdriver; then, push the panel toward the top of the instrument until the bottom of the panel is clear of the slot along the bottom rail of the instrument. Then, pull the panel out at the bottom and lift away from the instrument. The bottom panel is held in place with eight screws. The panels protect this instrument from dust in the interior, and also provide protection to personnel from the operating potentials present. They also reduce the emi radiation from this instrument or emi interference to the display due to other equipment.

RACK MODEL

The top cover is held in place with eight screws. To remove the cover, the six side screws need only be loosened slightly to slide the cover out of the slots.

A panel on the left side of the instrument, held in place with six screws, allows access to the Vertical Amplifier circuit board.

A cover on the rear of the instrument, held in place with four screws, allows access to the power supply regulating transistors. It also allows access to three of the five screws holding the Regulator circuit board assembly in the instrument.

(A)

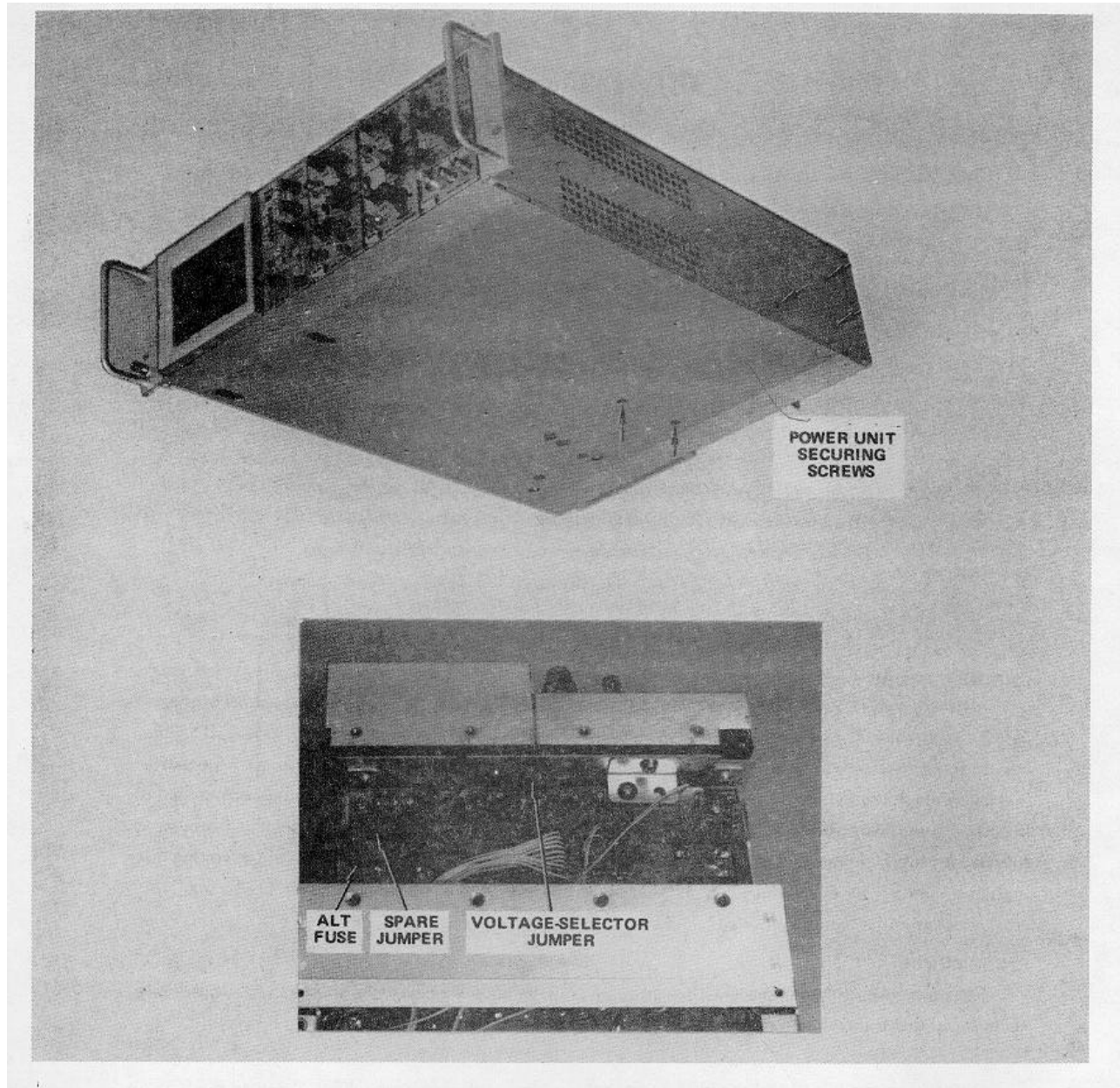

Figure 4-1. Power Unit removal.

POWER-UNIT REMOVAL

The power unit can be slid out of the back of the instrument to gain access to the Logic and Rectifier circuit boards and for power-unit maintenance. The power unit can be left connected to the rest of the instrument so that it can be operated in this position for troubleshooting. To remove the power unit, use the following procedure:

(A)

1. Remove the side panels (top panel for R7623A).
2. Remove the six screws which secure the power unit to the sides of the instrument, (see Fig.4-1 for locations of screws on R7623A).
3. Slide the power unit out of the rear of the Instrument until it can be set down on the work surface (guide the interconnecting cables so they do not catch on other parts of the instrument).

PREVENTIVE MAINTENANCE

Preventive maintenance consists of cleaning, visual inspection, lubrication, etc. Preventive maintenance performed on a regular basis may prevent instrument breakdown and will improve the reliability of this instrument. The severity of the environment to which the 7623A/R7623A is subjected determines the frequency of maintenance.

CLEANING

The 7623A/R7623A should be cleaned as often as operating conditions require. Accumulation of dirt in the Instrument can cause overheating and component breakdown. Dirt on components acts as an insulating blanket and prevents efficient heat dissipation. It also provides an electrical conduction path which may result in Instrument failure. The side panels provide protection against dust in the interior of the instrument. Operation without the panels in place necessitates more frequent cleaning.

CAUTION

A void the use of chemical cleaning agents which might damage the plastics used in this instrument. A void chemicals which contain benzene, toluene, xylene, acetone, or similar solvents.

EXTERIOR

Loose dust accumulated on the outside of the 7623A/R7623A can be removed with a soft cloth or small brush. The brush is particularly useful for dislodging dirt on and around the front-panel controls. Dirt which remains can be removed with a soft cloth dampened in a mild detergent and water solution. Abrasive cleaners should not be used.

AIR FILTER (R7623A only)

The air filter should be visually checked every few weeks and cleaned or replaced if dirty. More frequent inspections are required under severe operating conditions. If the filter is to be replaced, order new air filters from your local Tektronix Field Office or representative, order by Tektronix Part No 378-0041- 01. The following procedure is suggested for cleaning the filter

1. Remove the filter by pulling it out of the retaining frame on the rear panel. Be careful not to drop any of the accumulated dirt into the instrument.
2. Flush the loose dirt from the filter with a stream of hot water.

Maintenance-7623A/R7623A Service

3. Place the filter in a solution of mild detergent and hot water and let it soak for several minutes.
4. Squeeze the filter to wash out any dirt which remains.
5. Rinse the filter in clean water and allow it to dry.
6. Coat the dry filter with an air-filter adhesive (available from air conditioner suppliers or order Tektronix Part No.006-0580-00).
7. Let the adhesive dry thoroughly.
8. Re-install the filter in the retaining frame.

CRT

Clean the plastic light filter, faceplate protector, and the crt face with a soft, lint-free cloth dampened with denatured alcohol.

The optional crt mesh filter can be cleaned in the following manner'

1. Hold the mesh filter in a vertical position and brush lightly with a soft No.7 water- color brush to remove light coatings of dust or lint.
2. Greasy residues or dried-on dirt can be removed with a solution of warm water and a neutral-pH liquid detergent. Use the brush to lightly scrub the filter.
3. Rinse the filter thoroughly in clean water and allow to air dry.
4. If any lint or dirt remains, use clean low-pressure air to remove it. Do not use tweezers or other hard cleaning tools on the filter, as the special finish may be damaged.
5. When not In use, store the mesh filter in a lint-free, dust-proof container such as a plastic bag.

INTERIOR

Dust in the interior of this instrument should be removed occasionally due to its electrical conductivity under high-humidity conditions. The best way to clean the interior is to blow off the accumulated dust with dry, low-pressure air. Remove any dirt which remains with a soft brush or a cloth dampened with a mild detergent and water solution. A cotton-tipped applicator is useful for cleaning in narrow spaces or for cleaning ceramic terminal strips and circuit boards.

The high-voltage circuits, particularly parts located in the high-voltage compartment and the area surrounding the post-deflection anode lead, should receive special attention. Excessive dirt in these areas may cause high-voltage arcing and result in Improper instrument operation.

LUBRICATION

The reliability of potentiometers, switches, and other moving parts can be maintained if they are kept properly lubricated However, over-lubrication is as detrimental as too little lubrication. A lubrication kit containing necessary lubricants and instructions is available from Tektronix, Inc Order Part No. 003-0342-01.

(A)

VISUAL INSPECTION

The 7623A/R7623A should be Inspected occasionally for such defects as broken connections, improperly seated semiconductors, damaged or Improperly Installed circuit boards, and heat-damaged parts. The corrective procedure for most visible defects is obvious, however, particular care must be taken if heat-damaged components are found. Overheating usually indicates other trouble In the instrument, therefore, It is important that the cause of overheating be corrected to prevent recurrence of the damage

SEMICONDUCTOR CHECKS

Periodic checks of the semiconductors In the 7623A/R7623A are not recommended. The best check of semiconductor performance is actual operation in the instrument. More details on checking semiconductor operation are given under troubleshooting.

RECALIBRATION

To assure accurate measurements, check the calibration of this instrument after each 1000 hours of operation or every six months If used infrequently. In addition, replacement of components may necessitate recalibration of the affected circuits. The calibration procedure can also be helpful in localizing certain troubles in the instrument In some cases, minor troubles may be revealed or corrected by recalibration

TROUBLESHOOTING

The following information is provided to facilitate troubleshooting of the 7623A/R7623A. Information contained in other sections of this manual should be used along with the following information to aid in locating the defective component. An understanding of the circuit operation is very help- ful In locating troubles, particularly where integrated circuits are used. See the Theory of Operation section for complete Information.

TROUBLESHOOTING AIDS

DIAGRAMS

Complete circuit diagrams are given on foldout pages in the Diagrams section The component number and electrical value of each component in this instrument are shown on these diagrams. Important voltages and waveforms are also shown on the diagrams The portions of the circuit mounted on circuit boards are enclosed with blue lines

CIRCUIT BOARDS

Fig.4-2 shows the location of the circuit boards within the 7623A; Fig.4-3 shows the location of circuit boards in the R7623A. These circuit boards are shown in Figs.8-2 through 8-16 in the Diagrams section Each electrical component on the boards is identified by Its circuit number. A grid location guide is provided to aid in locating circuit components. The circuit boards are also outlined on the diagrams with a blue line to show which portions of the circuit are located on a circuit board.

(A)

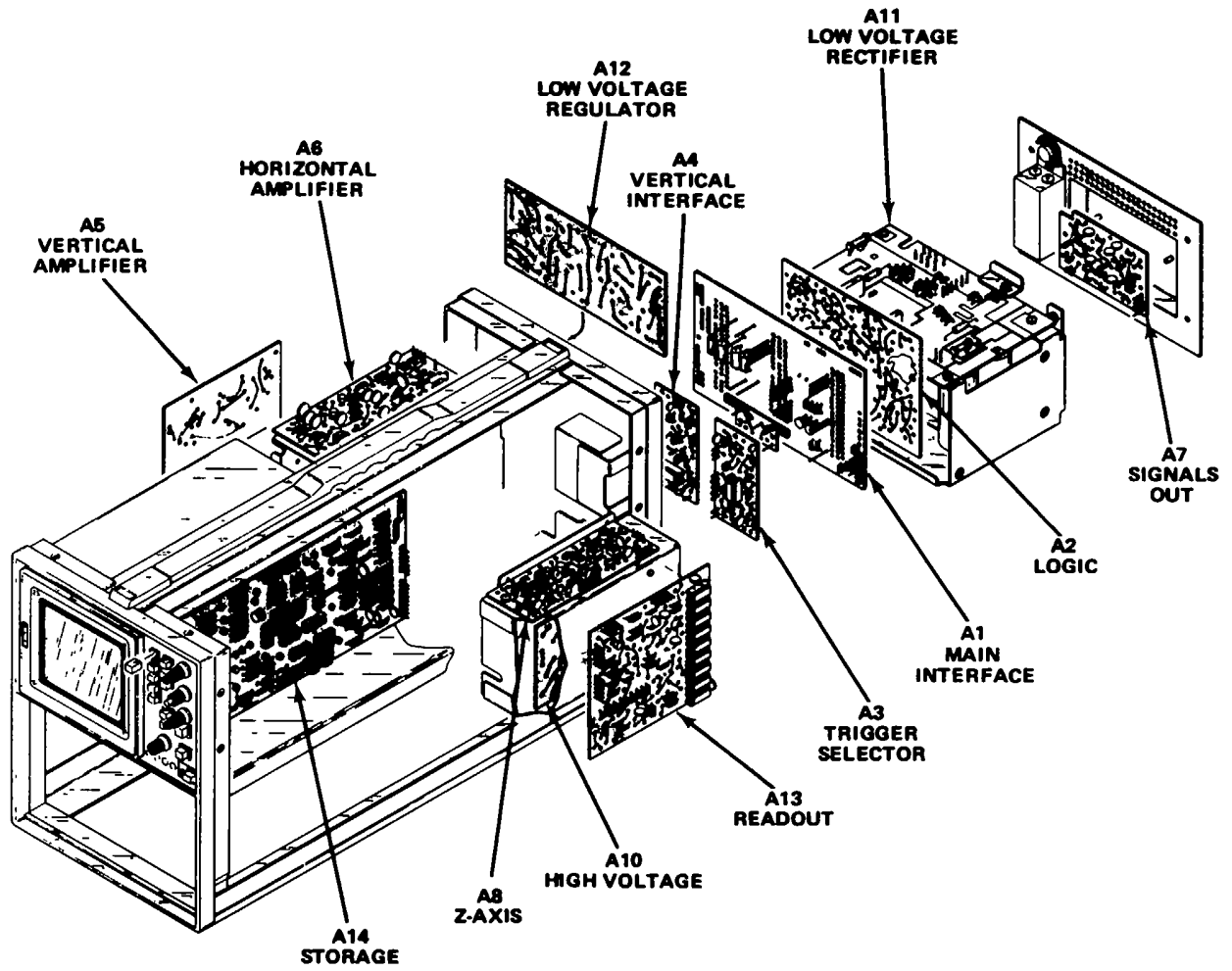

Figure 4-2. Location of circuit boards in the 7623A.

(A)

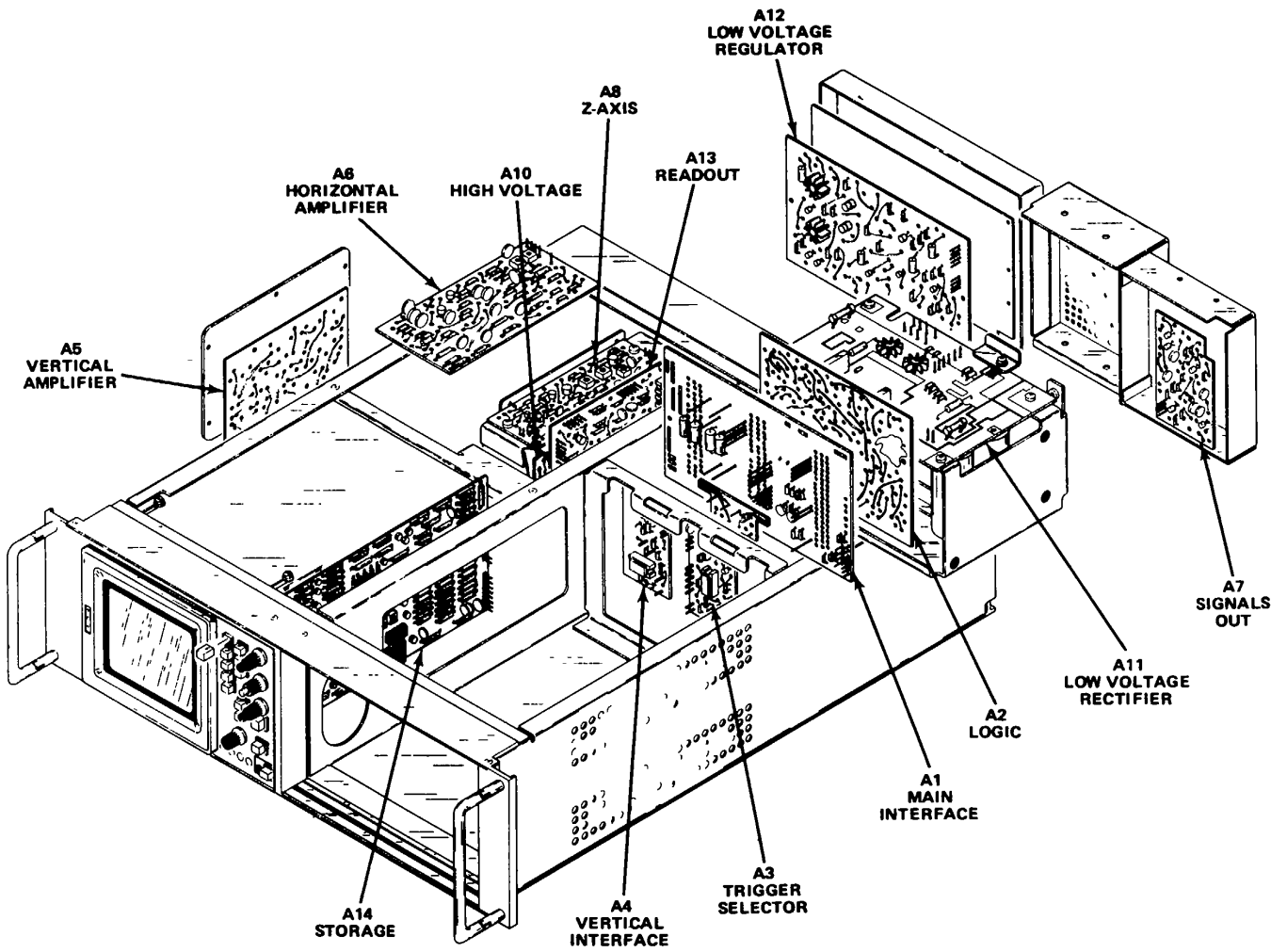

Figure 4-3. Location of circuit boards in the R7623A

(A)

Maintenance-7623A/R7623A Service

MULTI-PIN CONNECTOR COLOR-CODE

The multi-pin connectors used for interconnection between circuit boards are color-coded to aid in circuit tracing. The color of the connector body matches the resistor color-code for the last digit of the circuit number, e.g., P601 is brown, P603 is orange, etc.

WIRING COLOR-CODE

All insulated wire and cable used in the 7623A/R7623A is color-coded to facilitate circuit tracing.

TROUBLESHOOTING EQUIPMENT

The following equipment is useful for troubleshooting the 7623A/R7623A.

1. Transistor Tester

Description: Tektronix Type 576 Transistor-Curve Tracer or equivalent.

Purpose: To test the semiconductors used in this instrument.

2. Multimeters

Description: Digital voltmeter, 10 megohm input impedance and 0 to 500 volts range; ohmmeter, 0 to 2 megohms. Accuracy, within 1%. Test probes must be insulated to prevent accidental shorting.

Purpose: To check voltages and for general troubleshooting in this instrument.

NOTE

A 20,000 ohms/volt vom can be used to check the voltages in this instrument if allowances are made for the circuit loading of the vom at high-impedance points.

3. Test Oscilloscope

Description: Frequency response, dc to 50 megahertz; deflection factor, from 10 millivolts to 50 volts/division. A 10X probe should be used to reduce circuit loading.

Purpose: To check operating waveforms in this instrument.

TROUBLESHOOTING TECHNIQUES

This troubleshooting procedure is arranged in an order which checks the simple trouble possibilities before proceeding with extensive troubleshooting. The first few checks assure proper connection, operation, and calibration. If the trouble is not located by these checks, the remaining steps aid in locating the defective component. When the defective component is located, it should be replaced following the replacement procedures given under corrective maintenance.

1. Check Control Settings Incorrect control settings can indicate a trouble that does not exist. If there is any question about the correct function or operation of any control, see the Operating Information section.

(A)

Maintenance-7623A/R7623A Service

2. Check Associated Equipment. Before proceeding with troubleshooting of the 7623A/R7623A, check that the equipment used with this instrument is operating correctly. Check that the signal is properly connected and that the interconnecting cables are not defective. Also, check the power source. The associated plug-in units can be checked for proper operation by substituting other units which are known to be operating properly (preferably of the same types). If the trouble persists after substitution, the 7623A/R7623A is probably at fault.

3. Visual Check. Visually check the portion of the instrument in which the trouble is located. Many troubles can be located by visible indications such as unsoldered connections, broken wires, damaged circuit boards, damaged components, etc.

4. Check Instrument Calibration. Check the calibration of this Instrument, or the affected circuit if the trouble appears in one circuit. The apparent trouble may only be a result of misadjustment, or may be corrected by calibration. Complete calibration instructions are given in the Calibration section.

5. Isolate Trouble To A Circuit. To isolate trouble to a particular circuit, note the trouble symptom. The symptom often identifies the circuit in which the trouble is located. For example, poor focus indicates that the CRT Circuit (includes high-voltage supplies) is probably at fault. When trouble symptoms appear in more than one circuit, check affected circuits by taking voltage and waveform readings. Typical voltages and waveforms are given on the schematics in the Diagrams section.

Incorrect operation of all circuits often indicates trouble in the power supply. Check first for correct voltage of the individual supplies. A defective component elsewhere in the instrument can appear as a power-supply trouble and may also affect the operation of other circuits. Table 4-1 lists the tolerances of the power supplies in this instrument. These voltages are measured between the power-supply test points and ground. If a power-supply voltage is within the listed tolerance, the supply can be assumed to be working correctly. If outside the tolerance, the supply may be misadjusted or operating incorrectly. Use the procedure given in the Calibration section to adjust the power supplies.

TABLE 4-1.

Power Supply Tolerance and Ripple

Power Supply	Test Point	Output Voltage Tolerance	Maximum ripple (peak-to-peak)
-50 Volt	TP-50 (back of Main Interface board) on P1170-Pin 1	+0.1 volt	5 mV
-15 Volt	P1170-Pin 8	+0.3 volt	2 mV
+5 Volt	P1170-Pin 6	+0.15 volt	2mV
+15 Volt	P1170-Pin 5	+0.3 volt	2 mV
+50 Volt	P1170-Pin 4	+0.6 volt	5 mV
+130 Volt	P1170-Pin 3	+5.2 volts	300 mV

(A)

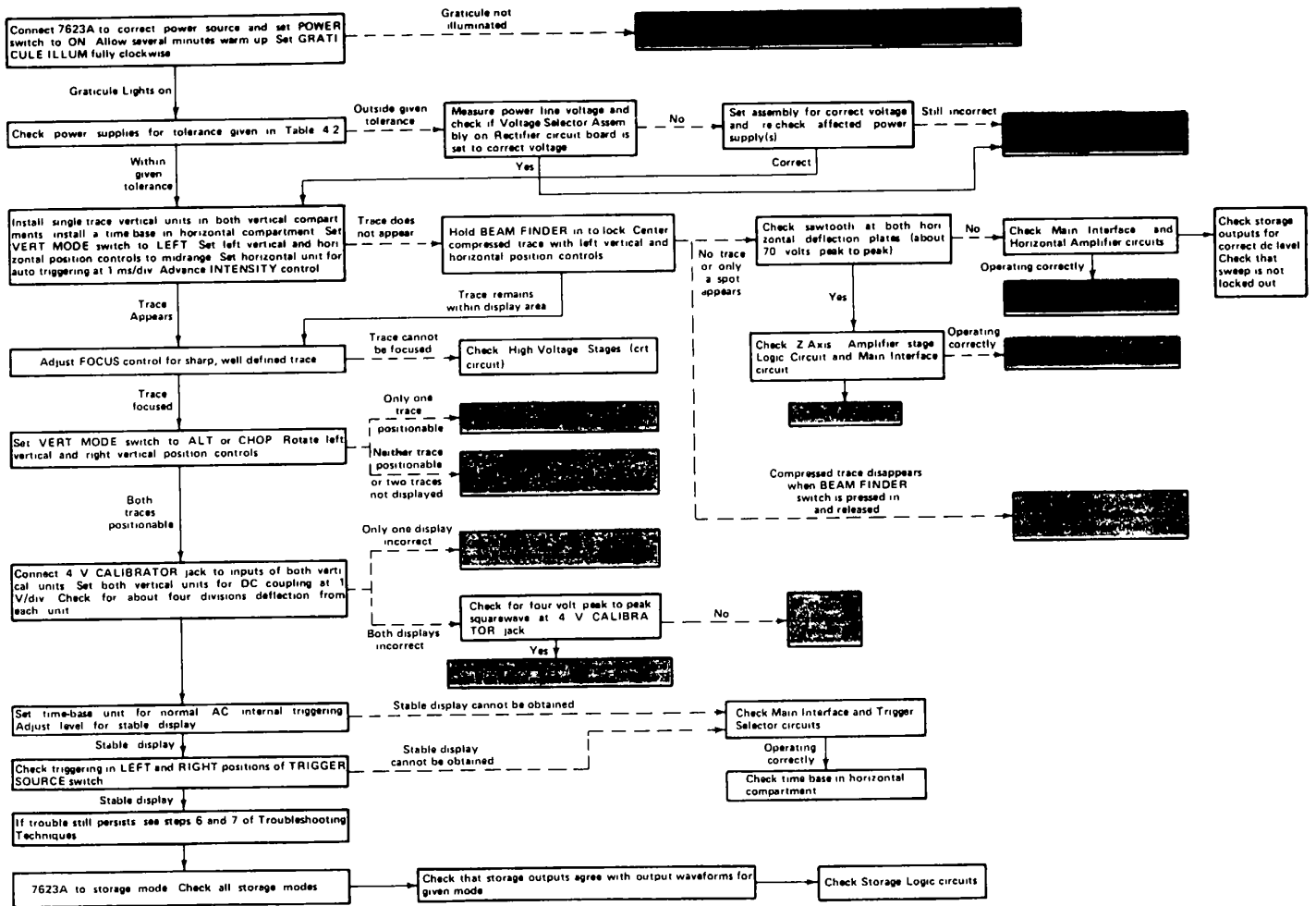

Figure 4-4. Circuit isolation troubleshooting chart

(A)

Fig.4-4 provides a guide for locating a defective circuit. This chart does not include checks for all possible defects; use steps 6 and 7 in such cases. Start from the top of the chart and perform the given checks on the left side of the page until a step is found which does not produce the indicated results. Further checks and/or the circuit in which the trouble is probably located are listed to the right of this step.

If incorrect operation of the power supplies is suspected, connect the 7623A/R7623A to a variable auto-transformer. Then, check for correct regulation with a dc voltmeter (0.1% accuracy) and correct ripple with a test oscilloscope while varying the autotransformer throughout the regulating range of this instrument.

After the defective circuit has been located, proceed with steps 6 and 7 to locate the defective component(s).

6. Check Voltages and Waveforms. Often the defective component can be located by checking for the correct voltage or waveform in the circuit. Typical voltages and waveforms are given on the diagrams.

NOTE

Voltages and waveforms given on the diagrams are not absolute and may vary slightly between instruments. To obtain operating conditions similar to those used to take these readings, see the test conditions given preceding the diagram.

7. Check Individual Components. The following procedures describe methods of checking individual components in the 7623A/R7623A. Components which are soldered in place are best checked by first disconnecting one end. This isolates the measurement from the effects of surrounding circuitry.

A. SEMICONDUCTORS.

CAUTION

Power switch must be turned off before removing or replacing semiconductors

A good check of transistor operation is actual performance under operating conditions. A transistor can most effectively be checked by substituting a new component for it (or one which has been checked previously). However, be sure that circuit conditions are not such that a replacement transistor might also be damaged. If substitute transistors are not available, use a dynamic tester. Static-type testers are not recommended, since they do not check operation under simulated operating conditions.

Integrated circuits can be checked with a voltmeter, test oscilloscope, or by direct substitution. A good understanding of the circuit operation is essential to troubleshooting circuits using integrated circuits. In addition, operating waveforms, logic levels, and other operating information for the integrated circuits are given in

(A)

Maintenance-7623A/R7623A Service

the Theory of Operation section. Use care when checking voltages and waveforms around the integrated circuits so adjacent leads are not shorted together. A convenient means of clipping a test probe to the 14- and 16-pin integrated circuits is with an integrated-circuit test clip. This device also doubles as an integrated-circuit extraction tool.

B. DIODES.

A diode can be checked for an open or for a short circuit by measuring the resistance between terminals with an ohmmeter set to the R X 1k scale. The diode resistance should be very high in one direction and very low when the meter leads are reversed. Do not check tunnel diodes or back diodes with an ohmmeter.

CAUTION

Do not use an ohmmeter scale that has a high internal current. High currents may damage the diodes under test.

C. RESISTORS.

Check the resistors with the ohmmeter. See the Electrical Parts List for the tolerance of the resistors used in this instrument. Resistors normally do not need to be replaced unless the measured value varies widely from the specified value.

D. INDUCTORS.

Check for open inductors by checking continuity with an ohmmeter. Shorted or partially shorted inductors can usually be found by checking the wave-form response when high-frequency signals are passed through the circuit. Partial shorting often reduces high-frequency response (roll-off).

E. CAPACITORS.

A leaky or shorted capacitor can best be detected by checking resistance with an ohmmeter on the highest scale. Do not exceed the voltage rating of the capacitor. The resistance reading should be high after initial charge of the capacitor. An open capacitor can best be detected with a capacitance meter or by checking if the capacitor passes ac signals.

8. Repair and Readjust the Circuit. If any defective parts are located, follow the replacement procedures given in this section. Be sure to check the performance of any circuit that has been repaired or that has had any electrical components replaced.

REV.B, APR.1975

Maintenance-7623A/R7623A Service

CORRECTIVE MAINTENANCE

Corrective maintenance consists of component replacement and Instrument repair. Special techniques required to replace components In this instrument are given here.

OBTAINING REPLACEMENT PARTS

STANDARD PARTS

All electrical and mechanical part replacements for the 7623A/R7623A can be obtained through your local Tektronix Field Office or representative However, many of the standard electronic components can be obtained locally In less time than is required to order them from Tektronix, Inc Before purchasing or ordering replacement parts, check the parts list for value, tolerance, rating, and description.

NOTE

When selecting replacement parts, it is important to remember that the physical size and shape of a component may affect its performance In the instrument, particularly at high frequencies All replacement parts should be direct replacements unless It is known that a different component will not adversely affect instrument performance.

SPECIAL PARTS

In addition to the standard electronic components, some special components are used in the 7623A/ R7623A. These components are manufactured or selected by Tektronix, Inc. to meet specific performance requirements, or are manufactured for Tektronix, Inc in accordance with our specifications Most of the mechanical parts used In this Instrument have been manufactured by Tektronix, Inc Order all special parts directly from your local Tektronix Field Office or representative

ORDERING PARTS

When ordering replacement parts from Tektronix, Inc , include the following information

1. Instrument type
2. Instrument serial number
3. A description of the part (if electrical, include circuit number)
4. Tektronix part number

SOLDERING TECHNIQUES

The reliability and accuracy of this instrument can be maintained only if proper soldering techniques are used when repairing or replacing parts

WARNING

Disconnect the instrument from the power source before soldering.

(A)

Maintenance-7623A/R7623A Service

General soldering techniques which apply to maintenance of any precision electronic equipment should be used when working on this instrument. Use only 60/40 rosin-core electronic-grade solder. The choice of soldering iron is determined by the repair to be made. When soldering on circuit boards, use a 35- to 40-watt pencil-type soldering Iron with a 1/8 inch wide, wedge-shaped tip. Keep the tip properly tinned for best heat transfer to the solder joint. A higher wattage soldering iron may separate the wiring from the base material. Avoid excessive heat, apply only enough heat to remove the component or to make a good solder joint. Also, apply only enough solder to make a firm solder joint, do not apply too much solder.

For metal terminals (e.g., switch terminals, potentiometers, etc.) a higher wattage-rating soldering iron may be required. Match the soldering Iron to the work being done. For example, if the component, is connected to the chassis or other large heat-radiating surface, it will require a 75-watt or larger soldering iron. The pencil-type soldering iron used on the circuit board can be used for soldering to switch terminals, potentiometers, or metal terminals mounted in plastic holders.

After soldering is completed, clean the area around the solder connection with a flux-remover solvent. Be careful not to remove any information printed in the area.

COMPONENT REPLACEMENT

The exploded-view drawings associated with the Mechanical Parts List (located at rear of manual) may be helpful in the removal or disassembly of individual components or sub-assemblies.

WARNING

Disconnect the instrument from the power source before replacing components.

CIRCUIT BOARD REPLACEMENT

If a circuit board is damaged beyond repair, the entire assembly including all soldered-on components, can be replaced. Part numbers are given in the Mechanical Parts List.

Most of the circuit boards in this instrument are mounted on the chassis, pin connectors are used for interconnection with other circuits. Use the following procedure to remove the chassis-mounted circuit boards (removal instructions for the exceptions will be given later)

A. CHASSIS-MOUNTED BOARDS

1. Disconnect any pin connectors on the board or connected to other portions of the instrument. Note the order of these connectors so they can be correctly replaced.

(A)

Maintenance-7623A/R7623A Service

2. Remove the securing screws.
3. Remove the board.

4. To replace the board, reverse the order of removal. Match the arrows on the multi-pin connectors to the arrows on the board. Correct location of the pin connectors is shown in the circuit board illustrations in the Diagrams section

B. TRIGGER SELECTOR AND VERTICAL INTERFACE CIRCUIT BOARD REPLACEMENT.

The Trigger Selector and Vertical Interface circuit boards plug onto the front of the Main Interface circuit board. Use the following procedure to replace either board.

1. Remove the securing screws
2. Pull out on the edges of the board until the board clears the interconnecting terminals. Hold the board parallel to the Main Interface board until the board is free, so as not to bend the interconnecting terminals.
3. To replace the circuit board, position it so the interconnecting pins and sockets mate properly
4. Gently press the circuit board against the mounting surface. Be sure that all the interconnecting pins and sockets mate properly.
5. Replace the securing screws.

C. LOGIC CIRCUIT BOARD REPLACEMENT.

1. Slide out the power unit as described previously.
2. Disengage the plastic snaps which secure the sides of the board
3. Pull out on the edges of the board until the board clears the inter-connecting terminals. Hold the board parallel to the Main Interface board until the board is free, so as not to bend the interconnecting terminals
4. To replace the Logic board, position it so the guide holes in the board mate with the guide posts. Check that all the interconnecting pins and sockets mate properly.
5. Gently press the board against the Main Interface board until the plastic snaps secure the board.

D. MAIN INTERFACE CIRCUIT BOARD REPLACEMENT.

1. Slide out the power unit as described previously
2. Remove all of the plug-on circuit boards from the Main Interface board (remove plug-in units to gain access to plug-on boards on front of Main Interface board)
3. Disconnect the multi-pin connectors from the front and rear of the Main Interface board. Note the order of these connectors so they can be correctly replaced.

(A)

Maintenance-7623A/R7623A Service

4. Remove the three screws from inside each plug-in compartment which hold the plug-in Interface connectors to the chassis (total of nine screws) Also remove the hexagonal posts which secure the ground straps to the Main Inter- face board

5. Remove the Main Interface board assembly through the rear of the Instrument.

6 To replace the Main Interface board, reverse the order of removal. Match the arrows on the multi-pin connectors to the arrows on the board Correct location of the pin connectors is shown in the circuit board Illustration in the Diagrams section

E. REGULATOR CIRCUIT BOARD REPLACEMENT.

1 Remove the four screws which secure the protective cover to the rear of the Instrument. Remove the protective cover

2. Disconnect the pin connectors.

3. Remove the four screws which secure the Regulator and Fan-Motor subassembly cover to the rear frame of the instrument.

4. Remove the two screws which secure the Fan Motor, and remove the Fan Motor.

5. Remove the four screws which secure the plate to the heat radiator. Remove the plate.

6. Remove the power transistors from the back of the heat radiator. Note the location of each power transistor

7. To replace the Regulator board, reverse the order of removal.

NOTE

After replacing the power transistors, check that the transistor cases are not shorted to the heat radiator before applying power.

F. RECTIFIER BOARD REPLACEMENT.

To replace the Rectifier board, proceed as follows

1. Slide out the power unit as described previously

2. Disconnect the pin connectors from the board.

3. Disconnect the wires soldered to the top of the board

4. Unsolder all of the power transformer wires connected to the top of the board Use a vacuum-type desoldering tool to remove the solder from the hole In the circuit board.

5.Remove the screws holding each corner of the board to the chassis

6. To replace the Rectifier board, reverse the order of removal. Be sure that all of the transformer wires are properly placed before resoldering Match the arrows on the multi-pin connectors to the arrows on the board. Correct location of the pin connectors is shown on the circuit board Illustration in the Diagrams section.

G. PLUG-IN INTERFACE CONNECTORS.

The individual contacts of the plug-in interface connectors can be re-placed. However, it is recommended that the entire Main Interface board be replaced if a large number of the contacts are damaged. An alternative solution is to refer the maintenance of the damaged Main Interface board to your local Tektronix Field Office or representative. Use the following procedure to replace an individual contact of the plug-in interface connector.

1. Remove the Main Interface circuit board from the instrument as described previously.
2. Snap the connector cover (white plastic) off the side of the plug-in interface connector which needs repair.
3. Unsolder and remove the damaged contact.
4. Install the replacement contact. Carefully form it to the required shape to fit against the connector body.
5. Snap the connector cover back onto the plug-in interface connector. Check that the contact which was replaced is aligned with the other contacts.
6. Replace the Main Interface board.

H. ACCESS TO THE FAN MOTOR FOR THE 7623A.

1. Remove the four screws holding the Regulator subassembly to the main chassis (see Fig. 4-5).
2. Pull the Regulator subassembly out through the rear of the instrument as far as cables will permit.
3. Remove the two screws holding the motor to the bracket, be careful not to lose the spacers between the motor and the bracket.
4. To replace the motor, reverse the order of removal.

I. ACCESS TO THE FAN MOTOR FOR THE R7623A.

1. Remove the eight screws holding the Signals-Out rear panel to the chassis. Pull rear panel out as far as cables will permit (see Fig. 4-6).
2. Remove the four corner bolts securing the motor to the chassis.
3. To replace the motor, reverse the order of removal.

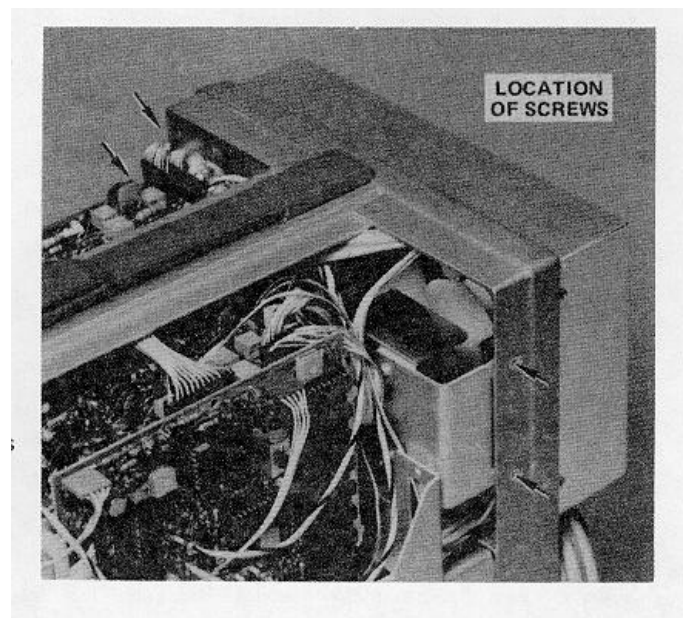

Figure 4-5. Location of screws holding Low-Voltage sub-chassis

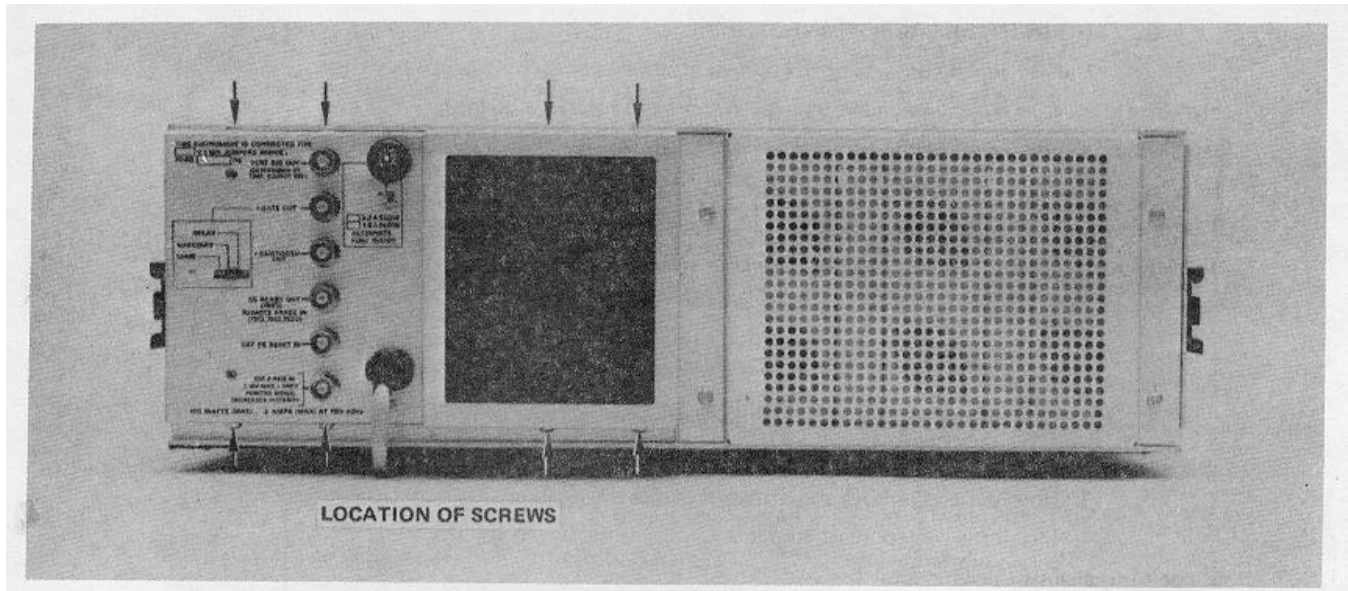

Figure 4-6. Location of screws holding Signals Out mar panel

SEMICONDUCTOR REPLACEMENT

Semiconductors should not be replaced unless actually defective. If removed from their sockets during routine maintenance, return them to their original sockets. Unnecessary replacement of semi-conductors may affect the calibration of this Instrument. When semi-conductors are replaced, check the operation of the part of the instrument which may be affected.

An extracting tool should be used to remove the 14- and 16-pin Integrated circuits to prevent damage to the pins. This tool is available from Tektronix, Inc Order Tektronix Part No.003-0619-00. If an extracting tool is not available when removing one of these Integrated circuits, pull slowly and evenly on both ends of the device. Try to avoid having one end of the Integrated circuit disengage from the socket before the other, as this may damage the pins.

CAUTION

POWER switch must be turned off before removing or replacing semi-conductors

Replacement semiconductors should be of the original type or a direct replacement. Fig 8-1 In the Diagrams Section shows the lead configuration of the semiconductors used in this instrument. Some plastic case transistors have lead configurations which do not agree with those shown here. If a replacement transistor is made by a different manufacturer than the original, check the manufacturer's basing diagram for correct basing. All transistor sockets in this instrument are wired for the standard basing as used for metal-cased transistors. Transistors which have heat radiators or are mounted on the chassis use silicone grease to increase heat transfer. Replace the silicone grease when replacing these transistors.

WARNING

Handle silicone grease with care. Avoid getting silicone grease in the eyes. Wash hands thoroughly after use.

ACCESS TO POWER TRANSISTORS

The power transistors associated with the Low-Voltage Power Supply are mounted on the heat radiator at the rear of the instrument. To gain access to these transistors, follow the procedure given previously for removing the Regulator circuit board. The power transistors can be removed from the heat radiator by taking out the screws in the mounting tabs (cases elevated above chassis; be sure power is off).

NOTE

After replacing a power transistor, check that the collector is not shorted to ground before applying power.

INTERCONNECTING PINS REPLACEMENT

Two methods of Interconnection are used in this Instrument to connect the circuit boards with other boards and components. When the Interconnection is made with a coaxial cable, a special end-lead connector plugs into a socket on the board. Other Interconnections are made with a pin soldered onto the board. Two types of mating connections are used for these interconnecting pins. If the mating connector is on the end of a lead, an end-lead pin connector is used which mates with the interconnecting pin. The following information provides the replacement procedure for the various types of Interconnecting methods.

A. COAXIAL-TYPE END-LEAD CONNECTORS.

Replacement of the coaxial-type end-lead connectors requires special tools and techniques, only experienced maintenance personnel should attempt replacement of these connectors. It is recommended that the cable or wiring harness be replaced as a unit. Refer to your local Tektronix Field Office or representative for replacement cables

B. CIRCUIT-BOARD PINS.

NOTE

A circuit-board pin replacement kit including necessary tools, Instructions, and replacement pins is available from Tektronix, Inc Order Tektronix Part No.040-0542-00.

To replace a pin which is mounted on a circuit board, first disconnect any pin connectors. Then, unsolder the damaged pin and pull it out of the circuit board with a pair of pliers. Be careful not to damage the wiring on the board with too much heat. Ream out the hole in circuit board with a 0.031-inch drill. Remove the ferrule from the new interconnecting pin and press the new pin into the hole in the circuit board. Position the pin in the same manner as the old pin. Then, solder the pin on both sides of the circuit board. If the old pin was bent at an angle to mate with a connector, bend the new pin to match the associated pins

(A)

C. CIRCUIT BOARD PIN SOCKETS.

The pin sockets on the circuit boards are soldered to the rear of the board. To replace one of these sockets, first unsolder the pin (use a vacuum-type desoldering tool to remove excess solder) Then straighten the tabs on the socket and remove it from the hole In the board. Place the new socket in the circuit board hole and press the tabs down against the board Solder the tabs of the socket to the circuit board; be careful not to get solder into the socket.

NOTE

The spring tension of the pin sockets ensures a good connection between the circuit board and the pin This spring tension can be destroyed by using the pin socket as a connecting point for spring-loaded probe tips, alligator clips, etc.

D. END-LEAD PIN CONNECTORS.

The pin connectors used to connect the wires to the interconnecting pins are clamped to the ends of the associated leads. To replace damaged end-lead pin connectors, remove the old pin connector from the end of the lead and clamp the replacement connector to the lead.

Some of the pin connectors are grouped together and mounted In a plastic holder, the overall result is that these connectors are removed and Installed as a multi-pin connector To provide correct orientation of this multi-pin connector when it is replaced, an arrow Is stamped on the circuit board and a matching arrow is molded into the plastic housing of the multi-pin connector. Be sure these arrows are aligned as the multi-pin connector is replaced. If the Individual end-lead pin connectors are removed from the plastic holder, note the color of the individual wires for replacement.

CATHODE-RAY TUBE REPLACEMENT

To replace the cathode-ray tube, proceed as follows'

WARNING

Use care when handling a crt Protective clothing and safety glasses should be worn. A void striking it on any object which might cause it to crack or implode. When storing a crt, place It in a protective carton or set it face down in a protected location on a smooth surface with a soft mat under the faceplate to protect it from scratches

A. REMOVAL.

1. Remove the Regulator sub-assembly as described previously.

(A)

2. Remove the crt base socket from the rear of the crt.
3. Loosen the two screws located on each side of the crt socket until the tension of the springs on these screws is released. Then, press In on the screws to be sure that the crt clamp is loose.
4. Disconnect the deflection-plate connectors. Be careful not to bend these pins.
5. Disconnect the crt anode plug from the jack located on the front of the high-voltage compartment. Ground this lead to the chassis to dissipate any stored charge.
6. Remove the four screws securing the crt bezel to the front panel. Remove the plastic faceplate protector and light filter.
7. Hold one hand on the crt faceplate and push forward on the crt base with the other. As the crt starts out of the shield, grasp It firmly. Guide the anode lead through the cutout in the crt shield as the crt is removed.

B. REPLACEMENT.

1. Loosen clamp blocks located at each corner of crt shield Insert the crt into the shield. Guide the anode lead through the hole in the crt shield.
2. Clean the crt faceplate, plastic faceplate protector, and the light filter with denatured alcohol.
3. Re-install the crt bezel, faceplate protector, and light filter Firmly tighten the screws.
4. Push forward on the crt base to be certain that the crt is as far forward as possible. Then tighten the two screws beside the crt base until the springs on the screws are fully compressed.
5. Reposition and tighten down clamp blocks to hold the faceplate of the crt tightly against the Implosion shield. The clamps are located at each corner of the crt shield.
6. Replace the crt base socket.
7. Reconnect the crt anode plug
8. Re-install the heat Regulator sub-assembly.
9. Carefully reconnect the deflection-plate connectors. After each connector is installed, lightly pull on its lead to be sure that it will remain In Its socket
10. Check the calibration of the complete instrument. Calibration procedure is given In Section 5

SWITCH REPLACEMENT

The push button switches used in the 7623A/R7623A are not repairable and should be replaced as a unit if defective.

(A)

Maintenance-7623A/R7623A Service

GRATICULE-BULB REPLACEMENT

To remove a graticule bulb, first remove the two screws (with tab), securing the crt bezel to the front panel. Pull the white tabs to remove the graticule light assembly. Slide the lamp retaining strip from the base of the bulb (turn to the side). Pull the bulb out of the assembly. Reverse the order of removal for replacement.

POWER TRANSFORMER REPLACEMENT

Replace the power transformer only with a direct replacement transformer. When removing the transformer, tag the leads with the corresponding terminal numbers to aid in connecting the new transformer. After the transformer has been replaced, check the performance of the complete instrument using the procedure given in the Calibration section.

HIGH-VOLTAGE COMPARTMENT

The components located in the high-voltage compartment can be reached for maintenance or replacement by using the following procedure. The location of components on the High-Voltage board are shown on the circuit-board illustration.

NOTE

All solder joints in the high-voltage compartment should have smooth surfaces. Any protrusions may cause high-voltage arcing at high altitudes.

1. Remove the heat radiator/Regulator assembly as described previously.
2. Disconnect the crt base socket.
3. Disconnect the crt anode plug and discharge it to the chassis. Using an insulated probe or wire, discharge the lack portion of the crt anode connector to chassis ground.
4. Disconnect the multi-pin connectors on the Z-Axis Amplifier board.
5. Remove the screw on the bottom of the high-voltage compartment and the two screws located at the top.
6. Guide the high-voltage compartment away from the Instrument chassis. Be careful not to damage any of the components or the pin connectors on the High-Voltage or Z-Axis Amplifier circuit boards. Disconnect the multi-pin connectors on the High-Voltage board.
7. Using an insulated shorting strap, discharge the exposed connections to chassis ground.
8. Disconnect plug P1196 and the four screws which secure the High-Voltage board to the high-voltage compartment. Now all of the circuitry in the high-voltage box can be reached for maintenance.

REV.B, JAN 1975

Maintenance-7623A/R7623A Service

9. To replace the high-voltage compartment, reverse the above procedure. Be careful not to pinch any of the interconnecting wires when re-attaching the high-voltage compartment to the chassis.

FUSE REPLACEMENT

Table 4-2 gives the rating, location, and function of the fuses used in this instrument.

TABLE 4-2.
Fuse Rating

Circuit Number	Rating	Location	Function
F1000	3.2 A Slow	Rear panel	110-volt line
F1000	1.6 A Slow	Rectifier board	220-volt line
F814	2A Fast	Rectifier board	High voltage
F855	0.15 A Fast	Low-Voltage Regulator board	+130 volts

RECALIBRATION AFTER REPAIR

After any electrical component has been replaced, the calibration of that particular circuit should be checked, as well as the calibration of other closely related circuits. Since the low-voltage supply affects all circuits, calibration of the entire instrument should be checked if work has been done in the low-voltage supply or if the power transformer has been replaced.

INSTRUMENT REPACKAGING

If the Tektronix instrument is to be shipped to a Tektronix Service Center for service or repair, attach a tag showing owner (with address) and the name of an individual at your firm that can be contacted, complete Instrument serial number and a description of the service required. Save and re-use the package in which your instrument was shipped. If the original packaging is unfit for use or not available, repackage the instrument as follows:

1. Obtain a carton of corrugated cardboard having inside dimensions of no less than six inches more than the instrument dimensions, this will allow for cushioning. Refer to the following table for carton test strength.
2. Surround the instrument with polyethylene sheeting to protect the finish of the instrument.
3. Cushion the instrument on all sides by tightly packing dunnage or urethane foam between carton and instrument, allowing three inches on all sides.
4. Seal carton with shipping tape or industrial stapler.

SHIPPING CARTON TEST STRENGTH	
Gross Weight (lb)	Carton Test Strength (lb)
0-10	200
10-30	275
30-120	375
120-140	500
140-160	600

REV. C, FEB. 1977

PERFORMANCE CHECK/CALIBRATION

PRELIMINARY INFORMATION

Calibration Interval

To ensure instrument accuracy, check the calibration of the 7623A every 1000 hours of operation, or every six months if used infrequently. Before complete calibration, thoroughly clean and inspect this instrument as outlined in the Maintenance section

Tektronix Field Service

Tektronix, Inc. provides complete instrument repair and recalibration at local Field Service Centers and the Factory Service Center. Contact your local Tektronix Field Office or representative for further information

Using This Procedure

Index. To aid in locating a step in the Performance Check or Calibration procedures, an index is given preceding Part I-Performance Check and Part II-Calibration

Performance Check. The performance of this instrument can be checked, without removing the covers or making internal adjustments, by performing only Part I-Performance Check. This procedure checks the instrument against the tolerances listed as a Performance Requirement in the Specification section

Calibration Procedure. Completion of each step in Part II I-Calibration ensures that this instrument is correctly adjusted and performing within all given tolerances. Where possible, instrument performance is checked before an adjustment is made

Partial Procedures. A partial performance check or calibration is often desirable after replacing components, or to touch up the adjustment of a portion of the instrument between major recalibrations. To check or adjust only part of the instrument, start with the Equipment Required list preceding the desired portion of the procedure. To prevent unnecessary recalibration of other parts of the instrument, re-adjust only if the tolerance given in the CHECK- part of the step is not met. If re-adjustment is necessary, also check any steps listed in the INTERACTION- part of the step

TEST EQUIPMENT REQUIRED

The test equipment listed in Table 5-1, or equivalent, is required for complete calibration of the 7623A. Specifications given for the equipment are the minimum necessary for accurate calibration. Therefore, the equipment used must meet or exceed the listed specifications. Detailed operating instructions for the test equipment are not given in this procedure. Refer to the appropriate instruction manual if more information is needed

If only a Performance Check is to be performed, not all of the listed test equipment is required. Items used only for calibration are indicated by footnote 1. The remaining pieces of equipment are common to both procedures

(A)

Performance Check/Calibration-7623A/R7623A Service

Special Calibration Fixtures

Special calibration fixtures are used only where they facilitate Instrument calibration. These V fixtures are available from Tektronix, Inc. Order by part number through your local Tektronix Field Office or representative.

Calibration Equipment Alternatives

All of the listed test equipment is required to completely check and calibrate this Instrument. However, complete checking or calibration may not always be necessary or desirable. The user may be satisfied with checking only selected characteristics, thereby reducing the amount of test equipment actually required.

The Performance Check and Calibration procedures are based on the first item of equipment given as an example. When other equipment is substituted, control settings or calibration setup might need to be altered. If the exact item of equipment given as an example in the Test Equipment list is not available, first check the specifications column carefully to see if any other equipment might suffice. Then check the Usage column to see what this item is used for. If used for a check or adjustment that is of little or no importance to your measurement requirements, the item and corresponding step(s) can be deleted.

The following procedures are written to completely check and adjust the 7623A to the Performance Requirements listed in the Specifications section and in the Operators manual, and to allow interchangeability of plug-in units between mainframes without the need to completely recalibrate the Instruments each time. If the applications for which you will use the 7623A do not require the full available performance from the 7623A and plug-in combinations, the procedures and the required equipment list can be shortened accordingly. For example, the basic measurement capabilities of this Instrument can be verified by just checking vertical deflection accuracy and basic horizontal timing with 7000-Series real-time plug-in units and the 7623A Calibrator signal. Also, if the 7623A and plug-in combination is to be used as a fixed system without the need to interchange the plug-in units, all tests can be made by substituting amplifier plug-in units and applicable test signals for the 067-0587-01 Signal Standardizer Calibration Fixture.

Signal Connections

Detailed signal-connection information is not given in this procedure except when critical for a particular test. In general, the rear-panel output connectors should be connected to other equipment with 50-ohm BNC cables. Use a BNC T connector to simultaneously connect a signal to two inputs. Signal-connection and termination information for the test equipment should be available in the associated instruction manual.

Warm-up and Temperature Requirements

Calibration of the 7623A/R7623A should be performed after a 30-minute warm-up period in the BISTABLE Storage mode in an ambient temperature of $+25^{\circ}\text{C}$, $\pm 5^{\circ}\text{C}$.

Performance Check/Calibration-7623A/R7623A Service

TABLE 5-1.
Test Equipment

Description	Minimum Specifications	Usage	Examples of Applicable Test Equipment
1. Precision DC voltmeter	Range, zero to 150 volts; accuracy, within 0.1%.	Calibrator output accuracy check and adjustment.	a. Tektronix DM 501 Digital Multimeter. ² b. Fluke Model 825A Differential DC Voltmeter.
2. DC voltmeter (vom) ¹	Range, zero to 4000 volts, accuracy, checked to within 1% at 1500 volts.	High-voltage power supply check. Z-Axis dc levels adjustment	a. Triplet Model 630-NA b. Simpson Model 262
3. Time-Mark generator	Marker outputs, 10 nanoseconds to 0.1 second; marker accuracy, within 0.1%; trigger output, one millisecond.	Crt geometry check and adjustment. Horizontal timing check and adjustment	a. Tektronix TM 501 Time-Mark Generator. ² b. Tektronix 2901 Time-Mark Generator.
4. Medium-frequency signal generator	Frequency range from 2.5 MHz to 100 MHz with 50-ohm output, output amplitude 1 V p-p, and accuracy within 2%.	Used throughout Performance Check and Calibration procedure.	a. Tektronix SG 503 Signal Generator. ² b. Tektronix Type 191 Constant Amplitude Signal Generator.
5. Low-frequency signal generator	Frequency, variable from 1.5 kHz to 2 MHz, output amplitude, variable from 50 mV to 2 V p-p into 50Ω.	X-Y phase shift check and storage writing rate checks and adjustments.	a. Tektronix FG 502 Function Generator. ² b. General Radio 1310-B Oscillator with a binding post to BNC adapter (274-QBJ General Radio)
6. Amplifier unit (two identical units required), and a dual display vertical unit	Tektronix 7A-series 65-megahertz bandwidth required for complete procedure as written.	Used throughout procedure to provide vertical input to the instrument Under calibration. Identical units required only for X-Y phase shift check	a. Tektronix 7A15A and a 7A26 Amplifier (may be shared with a 7000-Series test oscilloscope) b. Any 7A-Series plug-in unit (tolerances in some steps may be limited if low-frequency units used)

¹Used for calibration only; NOT used for performance check.

²Requires TM 500 Barim Power Module.

Performance Check/Calibration-7623A/R7623A Service

TABLE 5-1 (cont)

Description	Minimum Specifications	Usage	Examples of Applicable Test Equipment
7. Time-base unit	Tektronix 7B-Series	Used throughout procedure to provide sweep	a Tektronix 7B53A or 7B52 Time Base.
8. Mainframe standardizer calibration fixture	Produces gain-check and pulse-response waveforms	Used throughout procedure to standardize instrument so plug-in units can be Interchanged without complete recalibration	b. Any 7B-Series plug-in unit. a. Tektronix Calibration Fixture 067-0587-01. b. Calibrated 7000-Series plug-in units with suitable signal sources may be substituted if lower performance is acceptable
9 100X passive probe ¹	Compatible with 7B-Series external trigger input	Used throughout storage calibration	a. Tektronix P6053B or P6054A Probe(may be shared with test oscilloscope)
10 100X passive probe ¹	Compatible with test oscilloscope	Used for storage calibration	a. Tektronix P6009 Probe
11 Test oscilloscope	Bandwidth, dc to 100 MHz, minimum deflection factor 10 mV/div, accuracy within 3%	Used for performance check and calibration	a Tektronix 7603 Oscilloscope System with 7A15A Amplifier, 7B53A Time Base, and P6053B Probe. b. Tektronix 465 Oscilloscope with P6065A Probe
12 T connector	Connectors, BNC	External Z-axis operation check	a. Tektronix Part Number 103-0030-00
13 Termination	Impedance, 50-ohms, accuracy, $\pm 2\%$, connectors, BNC	Calibrator output check.	A. Tektronix Part Number 011-0049-01.
14 Cable (two required)	Impedance, 50 ohms, type, RG-58/U, length, 18 and 42 inches, connectors, BNC	Used throughout procedure for signal interconnection	a. Tektronix Part Number 012-0076-00 (18-inches). Tektronix Part Number 012-0057-01 (42-inches)
15. BNC to pin-lack cable	Adapts pin-lacks to BNC male connector	Used for calibrator signal connections	a. Tektronix Part Number 175-1178-00 (one supplied as standard accessory).

¹ Used for calibration only, NOT used for performance check.

(A)

Performance Check/Calibration-7623A/R7623A Service

PART I-PERFORMANCE CHECK

Introduction

The following procedure is intended to be used for incoming inspection to determine the accept ability of newly purchased or recently recalibrated instruments. This procedure does not check every facet of the instrument's calibration, rather, it is concerned primarily with those portions of the instrument essential to measurement accuracy and correct operation

Outline for Part I-Performance Check

A. CRT and Z-Axis Check	Page 5-8
1. Check Focus	Page 5-8
2. Check TRACE ROTATION	Page 5-8
3. Check External Z Axis	Page 5-9
B. Vertical Deflection System Check	Page 5-10
1. Check Vertical Gain	Page 5-10
2. Check Vertical Linearity	Page 5-11
3. Check Bandwidth	Page 5-11
4. Check Channel Isolation	Page 5-12
5. Check BEAMFINDER Operation	Page 5-12
6. Check Vertical Modes	Page 5-12
C. Horizontal Deflection System Check	Page 5-14
1. Check Horizontal Linearity	Page 5-14
2. Check High-Frequency Timing	Page 5-14
3. Check X-Y Phase Shift	Page 5-15
4. Check Horizontal Bandwidth	Page 5-16
D. Calibrator Check	Page 5-17
1. Check Calibrator Output Voltage	Page 5-17
2. Check Calibrator Repetition Rate	Page 5-18

(A)

E. Signals In/Out Check	Page 5-19
1. Check SS READY OUT-REMOTE ERASE	Page 5-19
2. Check EXT SS RESET IN	Page 5-19
3. Check VERT SIG OUT	Page 5-19
4. Check + SAWTOOTH OUT	Page 5-20
5. Check + GATE OUT	Page 5-20
F. Readout System Check	Page 5-21
1. Check READOUT Operation	Page 5-21
2. Check Readout Gate Trig'd Operation	Page 5-22
G. Storage System Check	Page 5-23
1. Check BISTABLE Writing Speed	Page 5-23
2. Check Periodic Erase	Page 5-24
3. Check SAVE and SAVE INTEN	Page 5-24
4. Check VAR PERSIST Writing Speed	Page 5-24
5. Check BISTABLE FAST Writing Speed	Page 5-26
6. Check VAR PERSIST FAST Writing Speed	Page 5-25

(A)

A. CRT AND Z AXIS

Equipment Required:

1. Signal Standardizer
2. Time-base unit
3. Amplifier unit
4. Low-frequency signal generator
5. 50-ohm BNC cables (2)
6. BNC T connector
7. Three-inch screwdriver

Control Settings

Preset the 7623A controls as follows'

INTENSITY	Midrange
VERT MODE	LEFT
TRIG SOURCE	VERT MODE
Display Selection	NON STORE

1. Check Focus

- a. Install the signal standardizer in the left vertical compartment Set the Test switch for Vert or Horiz Gain and the Rep Rate for one megahertz
- b. Install the time-base unit in the horizontal compartment Set the sweep rate for 0.5 milliseconds/division with auto, ac-coupled, internal triggering
- c. CHECK-That the focus can be varied by turning the FOCUS control

2. Check TRACE ROTATION

- a. Set the signal standardizer Test switch to Aux In and adjust the Position control to center the trace over the center graticule line
- b. CHECK-That the trace can be made parallel with the center graticule line with the TRACE ROTATION adjustment
- c. Remove the signal standardizer from the left vertical compartment

(A)

Performance Check/Calibration-7623A/R7623A Service

3. Check External Z-Axis

- a. Install an amplifier unit In the left vertical compartment and set the deflection factor to one volt/division.
- b. Connect the low-frequency signal generator to the input connector of the amplifier unit using the BNC T connector. Set the output frequency for one megahertz with an amplitude of two volts
- c. Connect a BNC cable to the EXT Z AXIS connector on the rear panel Connect the other end of the cable to the BNC T-connector on the Input of the amplifier unit.
- d. CHECK-That the positive slope of the sine wave is being blanked.
- e. Disconnect the test equipment and remove the amplifier unit from the 7623A.

(A)

B. VERTICAL DEFLECTION SYSTEM

Equipment Required:

1. Signal Standardizer
2. Time-base unit
3. Amplifier unit
4. Medium-frequency signal generator
5. 50-ohm BNC cables (2)
6. BNC to calibrator pin cable
7. BNC T connector

Control Settings

Preset the 7623A controls as follows:

INTENSITY	Midrange
VERT MODE	LEFT
TRIG SOURCE	VERT MODE
Display Selection	NON STORE

1. Check Vertical Gain

- a. Install a time-base unit in the horizontal compartment and set It for auto, internal, + slope triggering at a sweep rate of 50 microseconds/division.
- b. Install the signal standardizer in the left vertical compartment and set the Test switch to Vert or Horiz Gain and the Rep Rate to 100 kHz.
- d. CHECK-That the deflection of the seven center traces is six divisions t0.06 division. Note the exact deflection for part g of this step.
- e. Remove the signal standardizer from the left vertical compartment and insert it into the right vertical compartment.
- f. Set the VERT MODE to RIGHT.
- g. CHECK-That the deflection of the seven center traces is the same as in part d within 1%.

Performance Check/Calibration-7623A/R7623A Service

- h. Return the signal standardizer to the left vertical compartment and set the VERT MODE to LEFT.

2. Check Vertical Linearity

- a. Set the signal standardizer Test switch to Vert or Horiz + Step Resp and the Rep Rate to 100 kilohertz.
- b. Set the time-base unit for a triggered display at a sweep rate of one millisecond/division.
- c. Set the signal standardizer Position control to center the trace while adjusting the Amplitude control for a two-division display.
- d. CHECK-Position the two-division display vertically and check for not more than 0.1 division of compression or expansion anywhere within the graticule area.

3. Check Bandwidth

- a. Set the signal standardizer Test switch for Vert or Horiz Freq Resp and turn the Amplitude control fully clockwise.
- b. Connect the medium-frequency signal generator to the CW In connector of the signal standardizer
- c. Set the time-base unit for auto triggering at a sweep rate of five microseconds/division.
- d. Set the signal generator to a reference frequency of three megahertz and adjust the output amplitude for an eight-division display
- e. Adjust the signal standardizer Position control to bring the top of the waveform down one division.
- f. Adjust the amplitude of the signal generator to bring the top of the waveform back up to the top graticule line.
- g. Adjust the signal standardizer Position and Amplitude controls to obtain a centered, six-division display THE CW LEVELED LIGHT MUST STAY ON FOR THIS CHECK
- h. Set the signal generator to cover a range to 100 megahertz
- i. CHECK-That the 7623A display amplitude does not drop below 4.4 divisions as the signal generator frequency is adjusted upward to exactly 100 megahertz.(The signal standardizer CW LEVELED light must be on)
- j. Set the VERT MODE to RIGHT.
- k. Remove the signal standardizer from the left vertical compartment and Install It in the right vertical compartment
- l. Repeat steps g through i for the right vertical compartment
- m. Disconnect the signal generator and return the signal standardizer to the left vertical compartment.

(A)

Performance Check/Calibration-7623A/R7623A Service

4. Check Channel Isolation

- a. Install an amplifier unit in the right vertical compartment.
- b. Set the VERT MODE and TRIG SOURCE for RIGHT.
- c. Connect the medium-frequency signal generator to the input of the amplifier unit. Set the signal generator for 100-megahertz output and adjust the amplitude for an eight-division display.
- d. Set the time-base unit for a triggered display at a sweep rate of 0.5 microsecond/division.
- e. Set the VERT MODE to LEFT.
- f. CHECK-For a display of 0.1 division or less while adjusting the signal generator frequency dial from 100 megahertz to 50 megahertz. Do not include the trace width (line thickness) in this measurement.
- g. Interchange the amplifier unit and the signal standardizer. Leave the signal generator connected to the amplifier unit.
- h. Set the TRIG SOURCE for LEFT and adjust the amplitude for an eight-division display of the 100 megahertz input signal
- i. Set the VERT MODE to RIGHT.
- j. Repeat step e.
- k. Set the VERT MODE to LEFT and disconnect the signal generator.

5. Check BEAMFINDER Operation

- a. Set the position controls on the amplifier unit and the time-base unit clockwise.
- b. Press the BEAMFINDER pushbutton.
- c. CHECK-That the trace is within the graticule area.
- d. Set the position control on the amplifier unit and the time-base unit counterclockwise and repeat steps b and c

6. Check Vertical Modes

- a. Connect the calibrator 4 V output to the inputs of both the amplifier unit and the signal standardizer (Aux In).Set the signal standardizer Test switch for Aux In.
- b. Set the time-base unit for auto, internal triggering, at a sweep rate of 0.5 millisecond/ division
- c. Adjust the amplitude of the signal standardizer for two divisions of display and position the trace on the second and forth graticule lines.
- d Set the VERT MODE and TRIG SOURCE to RIGHT.

(A)

Performance Check/Calibration-7623A/R7623A Service

- e. Set the amplifier unit for about two divisions vertical deflection and position the trace on the sixth and eighth graticule lines
- f. Set the TRIG SOURCE to VERT MODE and the VERT MODE to ALT.
- g. CHECK-That traces from both vertical compartments appear on the crt.
- h. Set the VERT MODE to ADD.
- i. CHECK-That the resultant trace is the algebraic sum of the two vertical signals. For example, if the traces in steps c and e were exactly two divisions each, the resultant trace will be exactly four divisions.
- j. Set the VERT MODE to ALT and disconnect calibrator cables.
- k. Position the two traces about two divisions apart.
- l. Set the sweep rate to 50 milliseconds/division.
- m. CHECK-That the two vertical traces are alternately displayed with sweeps.
- n. Set VERT MODE to CHOP.
- o. CHECK-That two separate traces appear simultaneously on the crt
- p. Disconnect all test equipment and remove the plug-in units.

(A)

C. HORIZONTAL DEFLECTION SYSTEM

Equipment Required:

1. Signal Standardizer
2. Time-base unit
3. Amplifier unit (2 identical)
4. Time-mark generator
5. Low-frequency signal generator
6. 50-ohm BNC cables (2)

Control Settings

Preset the 7623A controls as follows:

INTENSITY	Midrange
VERT MODE	LEFT
TRIG SOURCE	VERT MODE
Display Selection	NON STORE

1. Check Horizontal Linearity

- a. Install the signal standardizer in the horizontal compartment and a time-base unit In the left vertical compartment
- b. Set the signal standardizer Test switch to Vert or Horiz + Step Resp and adjust the Amplitude and Position controls for a centered, two-division display.
- c. CHECK-That there is 0.1 division, or less, compression or expansion when the trace is positioned anywhere within the graticule area
- d. Remove the plug-in units

2. Check High-Frequency Timing

- a. Install an amplifier unit in the left vertical compartment and a time-base unit In the horizontal compartment
- b. Connect the time-mark generator to the input connector of the amplifier unit.
- c. Set the time-mark generator for one-millisecond markers and set the deflection factor of the amplifier unit so the markers are at least two division In amplitude.
- d. Set the time-base unit for auto, internal triggering at a sweep rate of one millisecond/division.
- e. Position the first marker to the left vertical line of the graticule.

(A)

- f. Set the time-base unit swp cal adjustment for one marker each major graticule division between the first and ninth lines.
- g. Set the time-mark generator for 10-nanosecond markers.
- h. Set the time-base unit for a sweep rate of 0.05 microsecond/division with the X10 magnifier on Set the deflection factor of the amplifier unit so the markers are about two divisions in amplitude
- i. CHECK-Refer to the time-base unit Instruction manual for performance check or calibration procedures for checking high-frequency timing and linearity Use the procedures and limits given for the three fastest sweep rates that do not exceed five nanoseconds/division.
- j. Disconnect the test equipment and remove the plug-in units from the 7623A.

3. Check X-Y Phase Shift

- a. Install identical amplifier units In the left vertical and horizontal compartments.
- b. Set both amplifier units for 10 millivolts/division deflection factor with dc coupling
- c. Connect the low-frequency signal generator to the inputs of both amplifier units
- d. Set the low-frequency generator for an output of 35 kilohertz and adjust the amplitude for a horizontal and vertical deflection of eight divisions
- e. CHECK-The lissajous display for an opening at the center vertical line of 0.28 division or less (indicates two degrees or less of phase shift, see Figure 5-1)
- f. Disconnect the low-frequency signal generator and remove the amplifier unit from the left vertical compartment

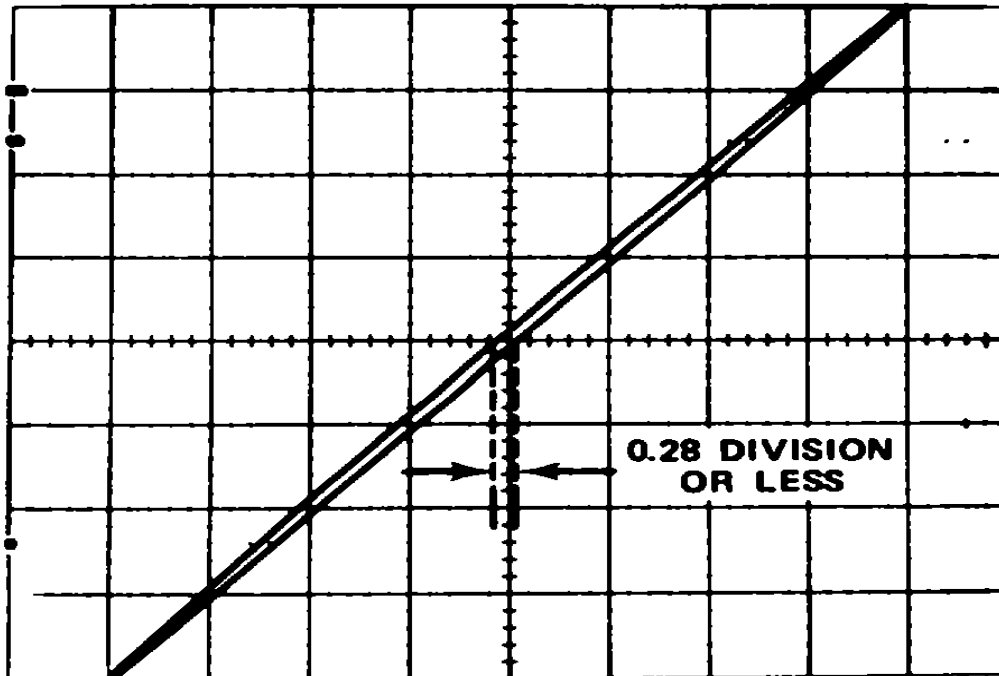

Figure 5-1. Typical crt display when checking X-Y phase shift.

(A)

Performance Check/Calibration-7623A/R7623A Service

4. Check Horizontal Bandwidth

- a. Install a time-base unit in the left vertical compartment.
- b. Set the time-base unit for auto triggering at a sweep, rate of one millisecond/division (display will free-run).
- c. Connect the low-frequency generator to the input of the amplifier unit in the horizontal compartment and adjust the amplitude and deflection factor for eight divisions of horizontal display of a 50-kilohertz reference frequency
- d. Without changing the output amplitude, increase the output frequency of the generator until the frequency is two megahertz
- e. CHECK-That the output horizontal amplitude is at least 5.6 divisions (amplitude is typically greater than seven divisions at two megahertz)
- f. Disconnect all test equipment and remove the plug-in units from the 7623A.

(A)

D. CALIBRATOR

Equipment Required:

1. Precision dc voltmeter
2. Amplifier unit
3. Time-base unit
4. BNC to pin-jack cable
5. Three-inch screwdriver

Control Settings

Preset the 7623A controls as follows:

INTENSITY	Midrange
VERT MODE	LEFT
TRIG SOURCE	VERT MODE
Display Selection	NON STORE

1. Check Calibrator Output Voltage

- a. Change jumper P1440 to the DC position (see Figure 5-2)

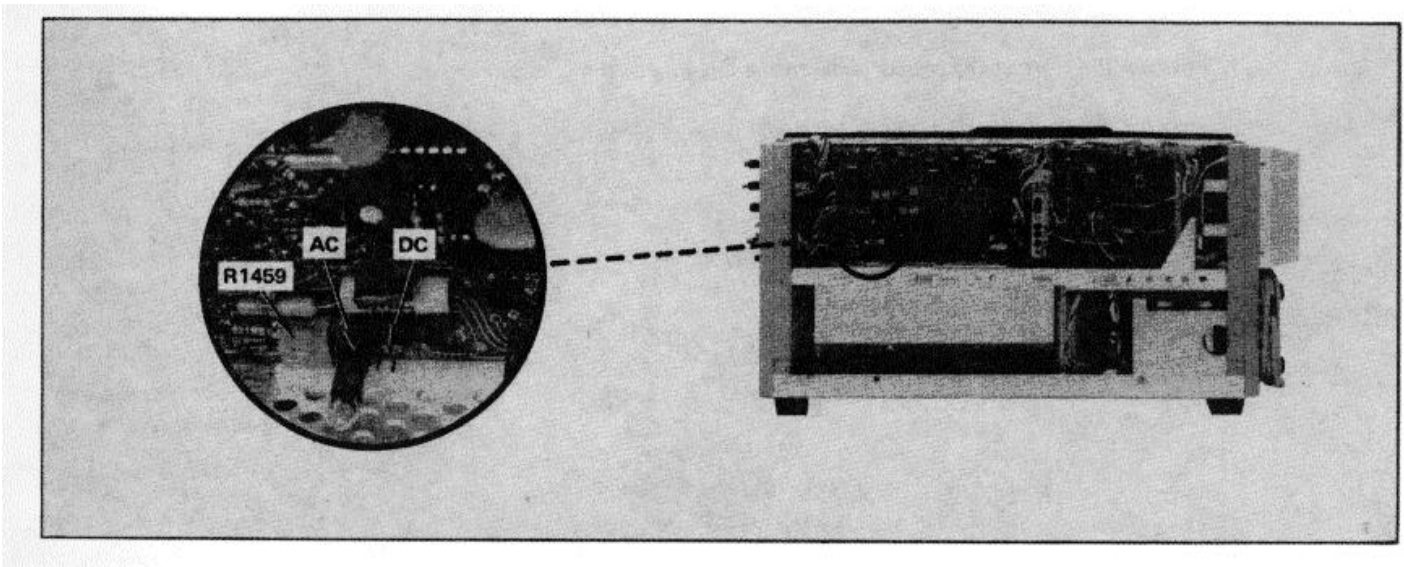

Figure 5-2. Location of Calibrator AC/DC jumper.

(A)

Performance Check/Calibration-7623A/R7623A Service

- b. Connect the precision dc voltmeter between the 4 V and GND pin jacks.
- c. CHECK-Meter reading; four volts ± 0.04 volt (within ± 0.08 volt if this measurement is made outside the +150C to +350C range).
- d. Connect the precision dc voltmeter between the 0.4 Volt Calibrator pin-jack and pin ground.
- e. CHECK-Meter reading; 0.4 volt ± 0.004 volt (within 0.00, volt if this measurement is made outside the +150C to +350C range).
- f. Connect the precision dc voltmeter between the 40 millivolt Calibrator pin-jack and pin ground.
- g. CHECK-Meter reading; 40 millivolts ± 0.4 millivolt (within 0.8 millivolt if this measurement is made outside the +150C to +350C range).
- h. Disconnect the precision dc voltmeter

2. Check Calibrator Repetition Rate

- a. Change jumper P1440 to the AC position (see Figure 5-2).
- b. Install the amplifier unit in the left vertical compartment and the time-base unit in the horizontal compartment
- c. Set the amplifier unit for a deflection factor of one volt/division.
- d. Set the time-base unit for auto, internal triggering at a sweep rate of 0.2 millisecond/division.
- e. Connect the four-volt calibrator pin-jack to the input of the amplifier unit with the BNC to pin-jack cable
- f. Position the start of the square wave to the left line of the graticule.
- g. CHECK-Crt display for length of one complete cycle between 4.2 and 6.3 divisions (one kilo- hertz $\pm 20\%$).

(A)

E. SIGNALS IN/OUT

(Option 7 deletes this procedure)

Equipment Required:

1. Amplifier units (two)
2. Time-base unit
3. 50-ohm BNC termination
4. BNC to pin-jack cable
5. Test oscilloscope
6. 50-ohm BNC cable

Control Settings

Preset the 7623A controls as follows:

INTENSITY	Midrange
VERT MODE	LEFT
TRIG SOURCE	VERT MODE
Display Selection	NON STORE

1. Check SS READY OUT-REMOTE ERASE

- a. Connect the calibrator signal to the input of the amplifier unit. Obtain a triggered display of two or more divisions.
- b. Press the STORE and VAR PERSIST pushbuttons.
- c. CHECK-That when the REMOTE ERASE input connector is grounded that an erase cycle is generated.
- d. Press the NON STORE pushbutton.

2. Check EXT SS RESET IN

- a. Set the time-base unit to Single Sweep at a sweep rate of 0.5 second/division.
- b. CHECK-That when the EXT SS RESET IN input is grounded that the time-base single sweep function is reset.

3. Check VERT SIG OUT

a. Set the time-base unit for auto triggering and adjust the trigger level for a stable display at a sweep rate of one microsecond/division.

b. Connect a BNC cable to the VERT SIG OUT connector and to the amplifier unit in the right vertical compartment. Set the TRIG SOURCE to LEFT.

(A)

Performance Check/Calibration-7623A/R7623A Service

- c. Connect the 0.4 volt CALIBRATOR signal to the input of the amplifier unit in the left vertical compartment. Set both vertical amplifiers for a deflection factor of 0.2 volt/division.
- d. CHECK-That a two-division signal is displayed by the left vertical amplifier.
- e. Set VERT MODE to RIGHT and check that a signal of about five divisions is displayed by the right vertical amplifier.
- f. Interchange the connections to the vertical amplifiers (VERT SIG OUT to the left amplifier and the calibrator to the right amplifier unit).Set the TRIG SOURCE to RIGHT.
- g. CHECK-That a two-division signal is displayed by the right vertical amplifier.
- h. Set the VERT MODE to LEFT and check that a signal of about five divisions is displayed.
- i. Install a 50-ohm termination between the VERT SIG OUT cable and the input of the left vertical amplifier
- j. Set the deflection factor of the left vertical to 10 millivolts/division Check for a display of about five divisions
- k. Disconnect all cables

4. Check + SAWTOOTH OUT

- a. Connect the + SAWTOOTH OUT to the input of the left vertical amplifier. Set the deflection factor of the left vertical amplifier for two volts/division.
- b. CHECK-For a sawtooth display of about five divisions in amplitude and greater than 10 divisions in length

5. Check + GATE OUT

- a. Connect the + GATE OUT to the vertical input of the test oscilloscope and set the deflection factor for two volts/division Set the time/division switch to 1 millisecond/division. Place the GATE selector switch in the MAIN GATE position
- b. CHECK-That the displayed signal is about five divisions in amplitude.

(A)

F. READOUT SYSTEM

(Option 1 deletes this procedure)

Equipment Required:

1. Dual trace vertical amplifier unit
2. Time-base unit

Control Settings

Preset the 7623A controls as follows:

INTENSITY	Midrange
READOUT	Midrange
VERT MODE	CHOP
TRIG SOURCE	VERT MODE
Display Selection	NON STORE

1. Check READOUT Operation

- a. Install the amplifier unit, set for dual trace mode, in the left vertical compartment.
- b. Push and hold the identify buttons on the amplifier unit Switch S2110, located on the Readout circuit board, should be in the free-run position (see Figure 8-23).
- c. CHECK-That the word IDENTIFY is within the top division and the bottom division of the graticule.
- d. CHECK-That the words IDENTIFY are positioned within the left third of the graticule area.
- e. Remove the amplifier unit from the left vertical compartment and install it in the right vertical compartment.
- f. Repeat steps b and c.
- g. CHECK-That the words IDENTIFY are positioned within the center third of the graticule area.
- h. Remove the amplifier unit from the right vertical compartment and install it in the horizontal compartment.
- i. Repeat steps b and c.
- j. CHECK-That the words IDENTIFY are positioned within the right third of the graticule area.
- k. Remove the amplifier unit from the horizontal compartment and install it in the left vertical compartment.

(A)

Performance Check/Calibration-7623A/R7623A Service

2. Check Readout Gate Trig'd Operation

- a. Set switch S21 10 to Gate Trig'd position (see Figure 8-23).
- b. Install the time-base unit in the horizontal plug-in compartment and set the sweep rate to 0.1 second/division.
- c. CHECK-That no readout Information is displayed till after the sweep. At fast sweep rates, this is not noticeable
- d. Remove the plug-in units from the 7623A.

(A)

G. STORAGE SYSTEM

Equipment Required:

1. Time-base unit
2. Amplifier unit
3. Low-frequency sine-wave generator
4. Medium-frequency sine-wave generator
5. 50-ohm BNC cable

Control Settings

Preset the 7623A controls as follows:

INTENSITY	Midrange
VERT MODE	LEFT
TRIG SOURCE	VERT MODE
READOUT INTENSITY	CCW (off)
Display Selection	NON STORE
ERASE/PERIODIC	CCW (in detent, off)
PERSISTENCE	CCW (maximum)
Storage Selection	BI STABLE
SAVE INTEN	Clockwise
STORAGE LEVEL	Two o'clock position

1. Check BISTABLE Writing Speed

- a. Install a time-base unit in the horizontal compartment and an amplifier unit in the left vertical compartment.
- b. Connect the low-frequency sine-wave generator to the amplifier unit and adjust for a 6 4-division display of a 1 5-kilohertz signal.
- c. Set the time-base unit for a sweep rate of 0.5 millisecond/division, with auto, ac-coupled, internal triggering
- d. Adjust the INTENSITY to maximum without blooming trace
- e. Press the STORE pushbutton
- f. Set the time-base unit for single sweep
- g. Press the ERASE pushbutton.

(A)

Performance Check/Calibration-7623A/R7623A Service

h. CHECK-That the single-shot sine wave stores and does not fade up or down in one minute. This checks the Bistable writing speed at 03 division/microsecond.

2. Check Periodic Erase

- a. Turn the PERIODIC ERASE knob fully clockwise (minimum time).
- b. CHECK-That erase period is less than or equal to two seconds.
- c. Turn the PERIODIC ERASE knob fully counterclockwise but not into the detent position (maximum time).
- d. CHECK-That the erase period is 10 seconds or greater.
- e. Turn the PERIODIC ERASE knob into the detent position.
- f. CHECK-That the display no longer erases automatically.

3. Check SAVE and SAVE INTEN

- a. Press the ERASE pushbutton.
- b. Press the SAVE pushbutton
- c. Press the ERASE pushbutton.
- d. CHECK-That the display will not erase.
- e. CHECK-That the screen goes dark as the SAVE INTEN control is turned counterclockwise.
- f. With the SAVE INTEN control fully counterclockwise, press the STORE pushbutton.
- g. Press the SAVE pushbutton
- h. CHECK-That the waveform display is visible during STORE but goes dark in SAVE.
- i. Press the NON STORE pushbutton
- f. CHECK-That the screen goes dark as the SAVE INTEN control is turned counterclockwise.
- g. With the SAVE INTEN control fully counterclockwise, press the STORE pushbutton.
- h. Press the SAVE pushbutton
- l. CHECK-That the Readout is visible during STORE but goes dark in SAVE.
- j. Press the NON STORE pushbutton and turn the READOUT INTENSITY off.

4. Check VAR PERSIST Writing Speed

a. Set the time-base unit in the 7623A for a sweep rate of 20 microseconds/division with auto, ac-coupled, internal triggering and set the amplifier unit for dc input

(A)

Performance Check/Calibration-7623A/R7623A Service

- b. Connect the low-frequency sine-wave generator to the amplifier unit input and adjust the amplitude for 6 4 divisions display of a 25-kilohertz signal (writing speed of 0.5 division/microsecond).
- c. Set the INTENSITY to maximum without blooming trace
- d. Set the time-base unit to single sweep
- e. Press the STORE and VAR PERSIST pushbuttons.
- f. CHECK-That the signal will store for 30seconds in the center 6 x 8 divisions of the graticule area (the PERSISTENCE control is in the counterclockwise position and the STORAGE LEVEL is in the two o'clock position).Increasing STORAGE LEVEL will increase writing speed while decreasing view time and vice versa.

5. BISTABLE FAST Writing Speed

- a. Press the NON STORE, FAST, and BISTABLE pushbuttons.
- b. Set the time-base unit for auto triggering and a sweep rate of two microseconds/division
- c. Connect the medium-frequency signal generator to the amplifier unit input and adjust the amplitude for a 6.4-division display of a 2.5-megahertz signal (writing speed is 50 divisions/microsecond).
- d. Turn INTENSITY to maximum without blooming trace.
- e. Set the time-base unit for single sweep.
- f. Turn STORAGE LEVEL to the two o'clock position.
- g. Press the STORE pushbutton.
- h. Press the ERASE pushbutton.
- i. CHECK-That the trace stores.

6. Check VAR PERSIST FAST Writing Speed

- a. Press NON STORE and set the time-base unit for auto triggering at a sweep rate of 0 1 micro- second/division.
- b. Adjust the medium-frequency signal generator to display 6 4 divisions of a 7.5-megahertz signal (writing speed of 150 divisions/microsecond)
- c. Turn the INTENSITY to maximum without blooming the trace.
- d. Set the time-base unit for single sweep (triggered).
- e. Press the VAR PERSIST and STORE pushbuttons.
- f. Set the STORAGE LEVEL control to the two o'clock position
- g. CHECK-That the signal will store after an erase cycle
- h. Disconnect all test equipment and remove the plug-in units. This completes the Performance Check procedure.

(A)

PART II CALIBRATION

Introduction

The following procedure returns the 7623 to correct calibration. All limits and tolerances given in this procedure are calibration guides and should not be interpreted as instrument specifications except as specified in the Specifications section of this manual.

Outline for Part 11-Calibration

A. Low Voltage Power Supply	Page 5-29
1. Adjust -50 Volt Power Supply	Page 5-29
2. Check Remaining Power Supply Voltages	Page 5-29
3. Check High-Voltage Power Supply	Page 5-30
B. CRT and Z Axis	Page 5-31
1. Adjust Z-Axis DC Levels	Page 5-31
2. Adjust Z-Axis Compensation and Check Drive	Page 5-32
3. Adjust Focus and Astigmatism	Page 5-33
4. Adjust Trace Rotation	Page 5-33
5. Adjust Y-Axis Alignment	Page 5-33
6. Adjust Geometry	Page 5-33
7. Adjust Auto Focus Compensation	Page 5-34
8. Adjust Auto Focus Bias and Gain	Page 5-34
9. Check External Z-Axis	Page 5-34
C. Vertical Deflection System	Page 5-35
1. Adjust Vertical Centering	Page 5-35
2. Adjust Vertical Gain	Page 5-35

(A)

Calibration-7623A/R7623A Service

3. Adjust Thermal Balance	Page 5-36
4. Check Vertical Linearity	Page 5-36
5. Adjust Vertical High-Frequency Compensation	Page 5-37
6. Check Bandwidth	Page 5-38
7. Check Channel Isolation	Page 5-39
8. Check BEAMFINDER Operation	Page 5-40
9. Check Vertical Modes	Page 5-40
D. Horizontal Deflection System	Page 5-41
1. Adjust Limit Center	Page 5-41
2. Adjust Horizontal Gain	Page 5-42
3. Adjust Position	Page 5-42
4. Check Horizontal Linearity	Page 5-42
5. Adjust High-Frequency Timing	Page 5-42
6. Check X-Y Phase Shift	Page 5-43
7. Check Horizontal Bandwidth	Page 5-43
E. Calibrator	Page 5-45
1. Adjust Calibrator Output Voltage	Page 5-45
2. Check Calibrator Repetition Rate	Page 5-46
F. Signals In/Out	Page 5-47
1. Check REMOTE ERASE	Page 5-47
2. Check EXT SS RESET IN	Page 5-47
3. Check VERT SIG OUT	Page 5-48
4. Check + SAWTOOTH OUT	Page 5-48
5. Check + GATE OUT	Page 5-48

(A)

Calibration-7623A/R7623A Service

G. Readout Operation	Page 5-49
1. Check READOUT Operation	Page 5-49
2. Check Readout Gate Trlg'd Operation	Page 5-50
H. Storage System	Page 5-51
1. Check/Adjust BISTABLE Operation	Page 5-52
2. Check Periodic Erase	Page 5-52
3. Check SAVE MODE and SAVE INTEN	Page 5-53
4. Check/Adjust BISTABLE FAST Operation	Page 5-53
5. Check/Adjust VAR PERSIST Operation	Page 5-54
6. Check/Adjust VAR PERSIST FAST Operation	Page 5-55
7. Check/Adjust VAR PERSIST FAST Stability	Page 5-57

(A)

A. LOW VOLTAGE POWER SUPPLY

Equipment Required:

1. Precision dc voltmeter
2. Three-inch screwdriver
3. DC Voltmeter (VOM)

Before you begin, see ADJUSTMENT LOCATIONS in the Diagrams section.

Control Settings

Preset the 7623A controls as follows:

INTENSITY	Counterclockwise (off)
VERT MODE	LEFT
TRIG SOURCE	LEFT
Display Selection	NON STORE

1. Adjust -50 Volt Power Supply

- a. Connect the precision dc voltmeter between -50 volts (see Figure 8-18) and chassis ground.
- b. CHECK-Meter reading, -50 volts +0 1 volt
- c. ADJUST- -50 volts adjustment R881 (see Figure 8-17) for a meter reading of exactly -50 volts.
- d. INTERACTION-Any change in the setting of R881 can affect the operation of all other circuits in the 7623A.

2. Check Remaining Power-Supply Voltages

- a. CHECK-Each supply with the precision dc voltmeter to ensure that all output voltages are within the tolerances given in Table 5-2. Power supply test points are shown in Figure 8-18.

NOTE

Ripple and regulation of the individual power supplies can be checked using the procedure given under Troubleshooting Techniques in Section 4

(A)

TABLE 5-2.

Power Supply Tolerances

Power Supply	Test Point	Output Voltage Tolerance
-50 Volt	Pin 8 of P1171	±0.1 Volt
-15 Volt	Pin 1 of P1171	±0 1 Volt
+5 Volt	Pin 2 of P1171	±0 1 Volt
+15 Volt	Pin 3 of P1171	±0 1 Volt
+50 Volt	Pin 4 of P1171	±0 3 Volt
+130 Volt	Pin 6 of P1171	±5 0 Volts

3. Check High-Voltage Power Supply

- a. Press the POWER switch to turn off the instrument
- b. Set the dc voltmeter (vom) to measure at least -1525 volts and connect it between the high-voltage test point (see Figure 5-3) and chassis ground
- c. Press the POWER switch to turn the instrument on
- d. CHECK-That the high-voltage test point measures -1475 volts +45 volts
- e. Press the POWER switch to turn OFF the instrument before disconnecting the voltmeter.
- f. Disconnect the voltmeter and press the POWER switch to turn the power back on.

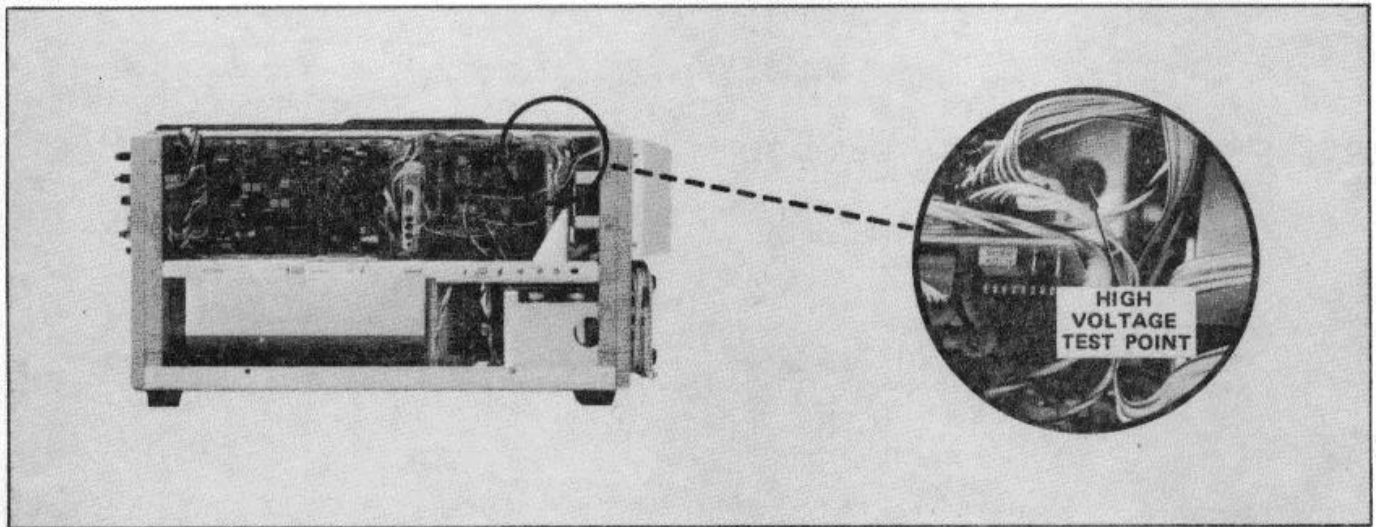

Figure 5-3. Location of High-Voltage Test Point

B. CRT AND Z-AXIS

Equipment Required:

1. Signal standardizer
2. Time-base unit
3. Low-frequency signal generator
4. 100X probe
5. Time-mark generator
6. 50-ohm BNC cable
7. Low-capacitance screwdriver
8. Test oscilloscope

Before you begin, see ADJUSTMENT LOCATION in the Diagrams section.

Control Settings

Preset the 7623A controls as follows:

INTENSITY	Counterclockwise (off)
VERT MODE	LEFT
TRIG SOURCE	LEFT
Display Selection	NON STORE
Storage Selection	VAR PERSIST
READOUT INTENSITY	Off (in detent)

1. Adjust Z-Axis DC Levels

- a. Install the signal standardizer set for Aux In, in the left vertical compartment and a time-base unit in the horizontal compartment.
- b. Set the time-base unit for a sweep rate of 10 millisecond/division and auto triggering
- c. Set the test oscilloscope for a vertical deflection factor of 10 volts/division at probe tip with dc input at a sweep rate of one millisecond/division
- d. Connect the 10X probe from the test oscilloscope to the output of the Z-Axis amplifier at R1118 (inside lead, see Figure 8-18).

(A)

Calibration-7623A/R7623A Service

- e. Turn the INTENSITY control on the 7623A to obtain a 15-volt signal amplitude on the test oscilloscope.
- f. ADJUST-CRT Grid Bias adjustment R1248 (see Figure 5-4) until the trace on the 7623A just disappears

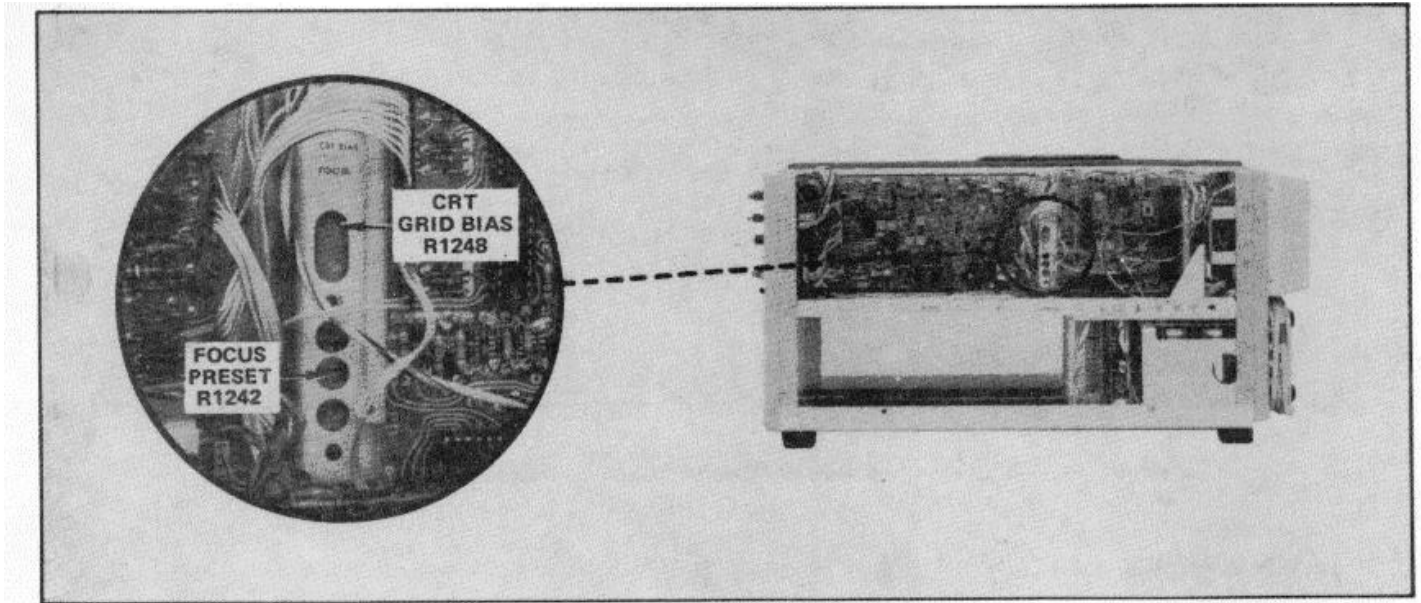

Figure 5-4. Location of adjustments in High-Voltage cover.

- g. Set the time-base unit for a sweep rate of 50 milliseconds/division
- h. Position the trace vertically off screen and turn the INTENSITY control fully clockwise
- i. CHECK-That the test oscilloscope display amplitude is 5 \pm volts or greater Note this reading
- j. Set the time-base unit for a sweep rate of 0.1 second/division
- k. CHECK-That the test oscilloscope display amplitude is between 20 and 30 volts less than the amplitude in step i

2. Adjust Z-Axis Compensation and Check Drive

- a. Set the time-base unit in the 7623A for a sweep rate of 0.5 microsecond/division
- b. Set the test oscilloscope for 0.5 volt/division (five volts/division at 10X probe tip) vertical deflection with dc coupling and for a sweep rate of 0.2 microsecond/division
- c. Position the 7623A trace off screen vertically

REV B.JUNE, 1976

Calibration-7623A/R7623A Service

- d. Adjust the 7623A INTENSITY control for a six-division display (30 volts) on the test oscilloscope.
- e. ADJUST-C1115 (see Figure 8-18) for optimum square leading corner and less than 1.5 volts (1.5 minor divisions) of aberration. Risetime should be less than 50 nanoseconds.
- f. Set the INTENSITY to midrange and center the trace vertically on the crt.
- g. Remove the 10X probe.

3. Adjust Focus and Astigmatism

- a. Set the front panel FOCUS control to midrange.
- b. Center the time-base unit Position control.
- c. Set the INTENSITY for a usable display.
- d. Set the signal standardizer to Aux In and connect the low-frequency signal generator to the Aux In connector. Adjust the amplitude for approximately one division vertical display of a 50-kilohertz sine wave.
- e. Set the time-base unit to display about five complete cycles of the sine wave
- f. ADJUST-Focus Preset R1242 (see Figure 5-4) and Astigmatism adjustment R1274 (see Figure 8-18) for the best overall focus.
- g. Disconnect the signal generator

4. Adjust Trace Rotation

- a. Set the center of the trace on the center horizontal graticule line.
- b. ADJUST-TRACE ROTATION so the trace is parallel with the center horizontal graticule line.

5. Adjust Y-Axis Alignment

- a. Interchange the time-base unit and the signal standardizer.
- b. Position the trace on the center vertical graticule line.
- c. ADJUST-R1284 (see Figure 8-18) to align the trace with the center vertical line.

6. Adjust Geometry

- a. Set the signal standardizer to Vert or Horiz Gain with a Rep Rate of 100 kilohertz
- b. ADJUST-Geometry adjustment R1292 for minimum bowing or tilt of the vertical traces
- c. CHECK-For less than 0.1 division of bowing or tilt of the vertical traces.

(A)

Calibration-7623A/R7623A Service

7. Adjust Auto Focus Compensation (Delete This Step for Option 1)

- a. Connect the 10X probe to the front end (see Figure 8-18) of RI166
- b. Set the test oscilloscope for ac coupling and a vertical deflection factor of 0.5 volt/division (5 volts/division at probe tip).
- c. Turn the READOUT control out of the detent position but leave it set to the counterclockwise end.
- d. Remove Q2225 from the Readout Board (see Figure 8-23).
- e. Adjust the 7623A INTENSITY for a six-division display on the test oscilloscope
- f. Set the test oscilloscope for negative slope triggering and a 10 microseconds/division sweep rate.
- g. ADJUST-C1159 (see Figure 8-18) for optimum square leading corner and minimum aberrations.
- h. Remove the probe and replace Q2225
- i. Turn the READOUT off

8. Adjust Auto Focus Bias and Gain

- a. Remove the signal standardizer and replace it with an amplifier unit (amplifier in vertical compartment and time-base in horizontal compartment). Connect the low-frequency signal generator to the amplifier input connector using a BNC T connector.
- b. Set the signal generator for one megahertz with approximately two volts amplitude and set the amplifier unit for a one-division display.
- c. Set the INTENSITY for midrange.
- d. ADJUST-Focus Gain adjustment RI147 for optimum focus.

9. Check External Z-Axis

- a. Connect a BNC cable from the unused end of the BNC T connector (connected to the input connector of the amplifier unit) to the 7623A EXT Z-AXIS input located on the rear panel.
- b. CHECK-That the positive slope of the sine wave is being blanked out
- c. Remove the signal generator and EXT Z-AXIS connections.
- d. Remove the amplifier unit from the vertical compartment

REV B, JUNE, 1976

C. VERTICAL DEFLECTION SYSTEM**Equipment Required:**

- | | | | |
|----|-----------------------------------|----|-----------------|
| 1. | Signal standardizer | 8. | BNC T connector |
| 2. | Time-base unit | | |
| 3. | Amplifier unit | | |
| 4. | Low-capacitance screwdriver | | |
| 5. | Medium-frequency signal generator | | |
| 6. | 50-ohm BNC cable (2) | | |
| 7. | Calibrator-pin to BNC cable | | |

Before you begin, see **ADJUSTMENT LOCATIONS** in the Diagrams section.

Control Setting

Preset the 7633 controls as follows:

INTENSITY	Midrange
VERT MODE	ALT
TRIG SOURCE	VERT MODE
Display Selection	NON STORE
READOUT INTENSITY	Off

1. Adjust Vertical Centering

- a. Install a time-base unit in the horizontal compartment and set it for auto, Internal, + slope triggering at a sweep rate of one millisecond/division.
- b. ADJUST-Vertical Centering adjustment R2433 (see Figure 8-20) to position the trace to the center horizontal graticule line.
- c. Set the VERT MODE to LEFT.

2. Adjust Vertical Gain

- a. Install the signal standardizer in the left vertical compartment. Set the Test switch for Vert or Horiz Gain and the Rep Rate to one kilohertz.
- b. Set the time-base unit for a sweep rate of 50 microseconds/division
- c. Position the bright center line of the display to the center horizontal graticule line.

(A)

Calibration-7623A/R7623A

- d. CHECK-That the deflection of the seven center traces is six divisions ± 0.06 division. Note the exact deflection for pan h of this step.
- e. ADJUST-Vertical Gain adjustment R2446 (see Figure 8- 20) for exactly ix divisions of deflection for the center seven traces.
- f. Remove the signal standardizer from the left vertical compartment and inert it into the right vertical compartment
- g. Set the VERT MODE to RIGHT.
- h. CHECK-That deflection of the seven center traces is the same as step 2d within 1% (six divisions ± 0.06 division if R2446 was adjusted).
- i. READJUST-Vertical Gain adjustment R2446, if necessary, for optimum gain for both vertical compartments.
- j. Remove the signal standardizer from the right vertical compartment and insert it into the left vertical compartment
- k. Set the VERT MODE to LEFT.

3. Adjust Thermal Balance

NOTE

If the instrument being calibrated is not equipped with readout feature, set the Thermal Balance control R2527 for a reading of +8.65 volts measured at the R2527 end of C2524 see Figure 820, and omit the part.

- a. Set the signal standardizer Test switch to + Step Resp and Amplitude to minimum Position the trace to the top graticule line.
- b. Install an amplifier unit n the right vertical compartment
- c. Set the VERT MODE to ALT Position the amplifier-unit trace on the bottom graticule line Set the time-base unit for a sweep rate of 10 milliseconds/division
- d. Set the 7623A INTENSITY to midrange and advance the READOUT INTENSITY till the readout is viewable.
- e. ADJUST-Thermal Balance control R2527 (see Figure 8-20) for minimum vertical movement of the displayed readout characters If appreciable adjustment is required, recheck the Vertical Gain adjustment in step C-2.

4. Check Vertical Linearity

- a. Remove the amplifier unit from the right vertical compartment
- b. Set the VERT MODE to LEFT
- c. Set the signal standardizer Test switch to Vert or Horiz + Step Reap and the Rep Rate to 100 kilohertz
- d. Set the time-base unit for a triggered display at a sweep rate of one millisecond/division

REV.B.JUNE, 1976

Calibration-7623A/R7623A

- e. Set the signal standardizer Position control to center the trace while adjusting the Amplitude control for a two-division display.
- f. CHECK-Position the two-division display vertically and check for not more than 0.1 division of compression or expansion anywhere within the graticule area

5. Adjust Vertical High-Frequency Compensation

- a. Install the signal standardizer in the left vertical compartment
- b. Set the VERT MODE to LEFT.
- c. Set the signal standardizer Amplitude and Position controls for a centered, six-division display. Set the Rep Rate for 100 kilohertz.
- d. Set the time-base unit for a sweep rate of one microsecond/division and adjust the trigger level for a stable display.
- e. CHECK-For optimum square corner and flat top on the displayed pulse with aberrations not to exceed ± 0.1 division with total peak-to-peak aberrations not to exceed 0.2 division
- f. ADJUST-R2409 (4), shown in Figure 8-20, for a flat pulse top and minimum aberrations in the first one-microsecond area.
- g. Set the time-base unit for a sweep rate of 0.5 microsecond/division and adjust the trigger level for a stable display.
- h. CHECK-For a flat top on the first 500-nanosecond portion of the pulse within the limits in step e.
- i. ADJUST-R2509 (5) for a flat pulse top in the first 500-nanosecond area.
- j. Set the signal standardizer Rep Rate to one megahertz and the time base for a sweep rate of 0.1 microsecond/division. Adjust the trigger level for a stable display
- k. CHECK-For a flat first 120-nanosecond area of the pulse top within the aberration limits listed in step e.
- l. ADJUST-R2511 (7) and C2511 (8) for flatness and minimum aberrations of the first 120-nanosecond area of the pulse top R2511 adjusts tilt and C2511 adjusts for flatness.
- m. Set the sweep rate to 0.05 microsecond/division and adjust the trigger level for a stable display
- n. CHECK-For a flat first 30 nanosecond area of the pulse top within the limits listed in step e
- o. ADJUST -R2411 (6) for flatness in the first 30-nanosecond area of the pulse top
- p. Set the sweep rate for 20 nanoseconds/division and adjust the trigger level for a stable display
- q. CHECK-For optimum leading corner and flat pulse top with minimum aberrations in the first 10-nanosecond area within the limits listed in step e

(A)

Calibration-7623A/R7623A Service

r. ADJUST-Refer to Table 5-3 for settings and adjustments for the first two, five, and 10 nanoseconds of the pulse. Aberrations should remain within the limits listed in step e.

NOTE

Because the adjustments in Table 5-3 are interactive, it may be necessary to repeat various steps listed in the procedure to obtain optimum response with minimum aberrations.

TABLE 5-3

Signal Standardizer Rep Rate	Best Sweep Rate (time/division)	Adjustment	Primary Area of Pulse Affected
100 kHz	1 microsecond	R2409 (4)	First microsecond
100 kHz	0.5 microsecond	R2509 (5)	First 500 nanoseconds
1 MHz	0 1 microsecond	R2511 (7) C2511 (8)	First 120 nanoseconds
1 MHz	0.05 microsecond	R2411 (6)	First 30 nanoseconds
1 MHz	20 nanoseconds	C2416 (11) R2416 (12) R2519 (13)	First 10 nanoseconds
1 MHz	20 nanoseconds	C2418 (9) R2418 (10)	First 5 nanoseconds
1 MHz	5 nanoseconds	C2456 (14)	First 2 nanoseconds
Adjust C2469 (located off the board) for minimum overall aberrations, 20 nanoseconds/division			

- s. Remove the signal standardizer from the left vertical compartment and install it into the right vertical compartment.
- t. Set the VERT MODE to RIGHT
- u. CHECK-For optimum square leading corner and flat top on the displayed pulse with aberrations not to exceed the limits listed in step e Use the sweep rate and Rep Rate settings as listed in steps a through r.
- v. ADJUST-If necessary, compromise the adjustments in steps a through r to obtain the best response for both left and right vertical compartments

NOTE

C2456 should be adjusted for least aberration of the front corner Then, as a final adjustment, the leading corner of the six-division trace should be vertically centered on the graticule and C2456 re-adjusted to obtain peak-to-peak aberration of exactly 0.2 division on the front corner. The trace should be repositioned to check that the aberrations are within specifications over the graticule area.

6.Check Bandwidth

- a. Install the signal standardizer in the left vertical compartment Set the Test switch for Vert or Horiz Freq Resp and turn the Amplitude control fully clockwise
- b. Set the VERT MODE to LEFT

Calibration-7623A/R7623A

- c. Connect the medium-frequency signal generator to the CW In connector of the signal standardizer.
- d. Set the timebase unit for auto triggering at a sweep rate of five microseconds/division.
- e. Set the signal generator to a reference frequency of three megahertz and adjust the output for an eight-division display.
- f. Adjust the signal standardizer Position control to bring the top of the waveform down one division.
- g. Adjust the amplitude of the signal generator to bring the top of the waveform back up to the top graticule line.
- h. Adjust the signal standardizer Position and Amplitude controls to obtain a centered, six- division display. THE CW LEVELED LIGHT MUST STAY ON FOR THIS CHECK
- i. Set the signal generator to cover a range to 100 megahertz.
- j. CHECK-That the 7623A display amplitude does not drop below 4.5 divisions as the signal generator frequency is adjusted upward to exactly 100 megahertz (The signal standardizer CW Leveled light must be on)
- k. Set the VERT MODE to RIGHT
- l. Remove the signal standardizer from the left vertical compartment and install it in the right vertical compartment.
- m. Repeat steps c through j for the right vertical compartment

7. Check Channel Isolation

- a. Install an amplifier unit in the right vertical compartment
- b. Set the VERT MODE and TRIG SOURCE for RIGHT.
- c. Connect the medium-frequency signal generator to the input of the vertical amplifier unit Set the generator for 100-megahertz output and adjust the amplitude for an eight division display. Set the time-base unit for 0.5 microsecond/division sweep rate.
- d. Set the VERT MODE to LEFT.
- e. CHECK-For a display of 0.1 division or less while adjusting the signal generator frequency from 100 megahertz to 50 megahertz Do not include the trace width (line thickness in this measurement.
- f. Interchange the amplifier unit and the signal standardizer. Leave the signal generator connected to the amplifier unit.
- g. Set the TRIG SOURCE for LEFT and adjust the amplitude for an eight-division display of the 100-megahertz input signal
- h. Set the VERT MODE to RIGHT.

(A)

Calibration-7623A/R7623A

- i. Repeat step e.
- j. Set the VERT MODE to LEFT and disconnect the signal generator.

8. Check BEAMFINDER Operation

- a. Set the position controls on the amplifier and time-base units clockwise.
- b. Press the BEAMFINDER pushbutton
- c. CHECK-That the trace s within the graticule area.
- d. Set the position controls on the amplifier and time-base units counterclockwise and repeat steps b and c

9. Check Vertical Modes

- a. Connect the calibrator, four-volt output to the inputs of both the amplifier unit and the signal standardizer (Aux In) Set the signal standardizer Test switch for Aux In.
- b. Adjust the amplitude of the signal standardizer for two divisions of display and position the trace on the second and fourth graticule lines
- c. Set the timebase unit for auto, internal triggering, at a sweep rate of 0.5 millisecond/ division
- d. Set the VERT MODE and TRIG SOURCE to RIGHT.
- e. Set the amplifier unit for about two divisions vertical deflection and position the trace on the sixth and eighth graticule lines.
- f. Set the TRIG SOURCE to VERT MODE and the VERT MODE to ALT.
- g. CHECK-That traces from both vertical compartments appear on the crt
- h. Set the VERT MODE to ADD
- i. CHECK-That the resultant trace s the algebraic sum of the two vertical signals. For example, if the traces in steps c and e were exactly two divisions each, the resultant trace will be exactly four divisions.
- j. Set the VERT MODE to ALT and disconnect the calibration cables
- k. Position the traces about two divisions apart
- l. Set the sweep rate to 50 milliseconds/division
- m. CHECK-That the two vertical traces are alternately displayed with sweeps.
- n. Set VERT MODE to CHOP.
- o. CHECK-That two separate traces appear simultaneously on the crt
- p. Disconnect all test equipment and remove plug-in units

REV 8, JUNE, 1976

D. HORIZONTAL DEFLECTION SYSTEM**Equipment Required:**

1. Test oscilloscope
2. 10X probes (2)
3. Signal standardizer
4. Low-frequency signal generator
5. BNC cable (2)
6. BNC T connector
7. Time-mark generator
8. Amplifier unit

Before you begin, see **ADJUSTMENT LOCATIONS** in the Diagrams section.

Control Settings

Reset the 7623A controls as follows:

INTENSITY	Midrange
READOUT INTENSITY	Off
VERT MODE	LEFT
TRIG SOURCE	VERT MODE
Storage Selection	NON STORE

1. Adjust Limit Center

- a. Install an amplifier unit, set for a vertical deflection factor 10 millivolts/division with dc coupling, into the horizontal compartment of the 7623A. Set the Position control to center range.
- b. Set the test oscilloscope for a 10microsecond sweep rate with auto, ac-coupled, internal triggering. Set the vertical deflection factor for 0.5 volt/division (5 volts/division at probe tip) on both channel inputs, alternate display mode, and set the inputs to ground.
- c. Connect 10X probes from the two vertical channel inputs of the test oscilloscope to the two horizontal deflection plate leads of the 7623A (see Figure 8-21).
- d. Adjust the vertical Position controls of the test oscilloscope to set both traces on the top graticule line
- e. Set the test oscilloscope vertical inputs to dc

(A)

Caibration-7623A/R7623A Service

- f. Connect the low-frequency signal generator to the input of the amplifier unit.
- g. Set he signal generator for 50-kilohertz output with 0.5 volt amplitude.
- h. ADJUST-R535 (see Figure 8-21) to bring the lower edges of the two traces to e same level.
- i. Disconnect the probes from the horizontal deflection plate leads.
- j. Disconnect the signal generator and remove the amplifier unit from the horizontal compartment.

2. Adjust Horizontal Gain

- a. Install a time-base unit n the left vertical compart ment and the signal standardizer in the horizontal compartment
- b. Set he signal standardizer Test switch to Vet or Horiz Gain and adjust the Position control to center the display.
- c. ADJUST-Gain adjustment R512 (see Figure 8-21) for exactly eight divisions between the second and eighth trace.

3. Adjust Position

- a. Set the signal standardizer Test switch to Triggering Gain.
- b. ADJUST-Position adjustment R525 (see Figure 8-21) to set the trace exactly on the center graticule line.

4. Check Horizontal Linearity

- a. Set the signal standardizer Test siwtch to Vert or Horiz + Step Resp. Adjust he Amplitude and Position controls for a centered, two-division display.
- b. CHECK-That there s 0.1 division or less compression or expansion when the trace s positioned anywhere within the graticule area.

5. Adjust High-Frequency Timing

- a. Install an amplifier unit in the left vertical compartment and a time-base unit in the hoizontal compartment.
- b. Connect the time-mark generator to the input connector of he amplifier unit.
- c. Set the time-mark generator for one-millisecond markers. Set the deflection factor of the amplifier unit so the markers are at least two divisions in amplitude.
- d. Set the time-base unit for auto, internal triggering at a sweep rate of one millisecond/division.
- e. Position the first marker to the left vertical line of the graticule.
- f. Set the time-base unit Swap Cal adjustment for one marker each major graticule division between the first and ninth lines
- i. CHECK-Refer to the time-base unit instruction manual for performance check or calibration procedure for checking high-frequency timing and linearity. Use the procedures and limits given for the fastest sweep rates which do not exceed five nanoseconds/division.

m. ADJUST-C588, C566, and C586 (see Figure 8-21), if necessary, for timing and linearity of the 10- and nanoseconds/division sweep rates (use low-capacitance screwdriver).C588 has the greatest effect on the 10-nanoseconds/division range, and C566-C586 have the greatest effect on the 5nanoseconds/dvsvion range.

n. Remove the amplifier and time-base units.

6. Check X-Y Phase Shift

a. Install identical amplifier units in the left vertical and horizontal compartments.

b. Set both amplifier units for 10 mllivolts/division deflection with dc coupling.

c. Connect the low-frequency signal generator to the inputs of both amplifier units.

d. Set the low-frequency generator r an output of 35 kilohertz and adjust the amplitude for a horizontal and vertical deflection of eight divisions.

e. CHECK-The lissajous display for an opening at the center vertical line of 0.28 division or less (indicates two degrees or less of phase shift; see Figure 5-5).

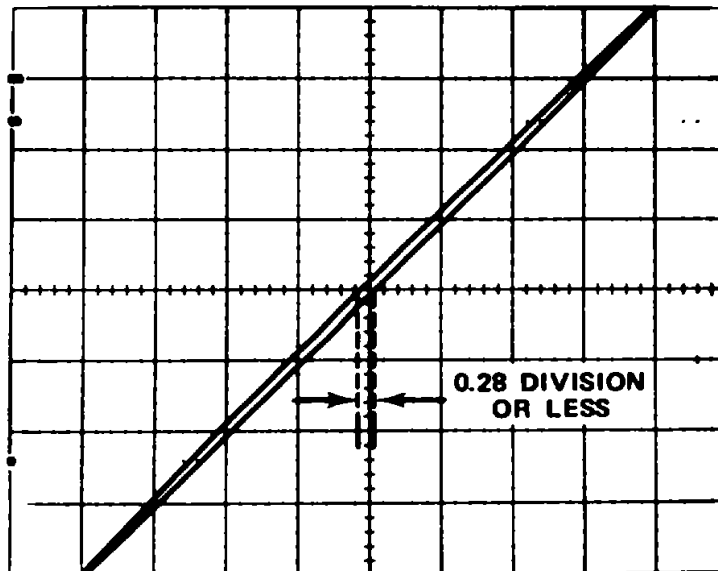

Figure 5-5. Typical crt display when checking X-Y phase. shift.

f. Disconnect the low-frequency signal generator and remove the amplifier unit from the left vertical compartment

7. Check Horizontal Bandwidth

a. Install a time-base unit In the left vertical compartment.

b. Set the time-base unit for auto triggering at a sweep rate of one millisecond/division (display will free-run).

c. Connect the low-frequency generator to the input of the amplifier unit in the horizontal compartment and adjust the amplitude and deflection factor for eight divisions of horizontal display of a 50-kilohertz reference frequency

(A)

Calibration-7623A/R7623A Service

- d. Without changing the output amplitude, increase the output frequency of the generator to two megahertz
- e. CHECK-That the horizontal amplitude is at least 5 6 divisions (amplitude s typically greater than seven divisions at two megahertz).
- f. Disconnect all test equipment and remove the plug-in units from the 7623A.

(A)

E. CALIBRATOR

Equipment Required:

1. Precision dc voltmeter
2. Amplifier unit
3. Time-base unit
4. BNC to pin-jack cable
5. Three-inch screwdriver

Before you begin, see **ADJUSTMENT LOCATIONS** in the Diagram section.

Control Setting

Preset the 7623A controls as follows.

INTENSITY	Midrange
VERT MODE	LEFT
TRIG SOURCE	VERT MODE
Display Selection	NON STORE
READOUT INTENSITY	Off (n detent)

1. Adjust Calibrator Output Voltage

- a. Change jumper P1440 (see Figure 5-6) to the DC position
- b. Connect the precision dc voltmeter between the 4 V and GND pin-jacks.
- c. CHECK-Meter reading, four volts ± 0.04 volt (within 0.08 volt if this measurement is made outside the +15°C to +35°C range).
- d. ADJUST-Calib adjustment R1459 (see Figure 8-24) for a meter reading of exactly four volts.
- e. Connect the precision dc voltmeter between the 0.4-volt Calibrator pinack and pin ground
- f. CHECK-Meter reading, 0.4 volt ± 0.004 volt (within 0.008 volt if this measurement is made outside the +15°C to +35°C range)
- g. Connect the precision dc voltmeter between the 40-millivolt Calibrator pin-lack and pin ground.
- h. CHECK-Meter reading, 40 millivolts ± 0.4 millivolt (within 0.8 millivolt if this measurement is made outside the +15°C to +35°C range)
- i. Disconnect the precision dc voltmeter

REV.B.JUNE, 1976

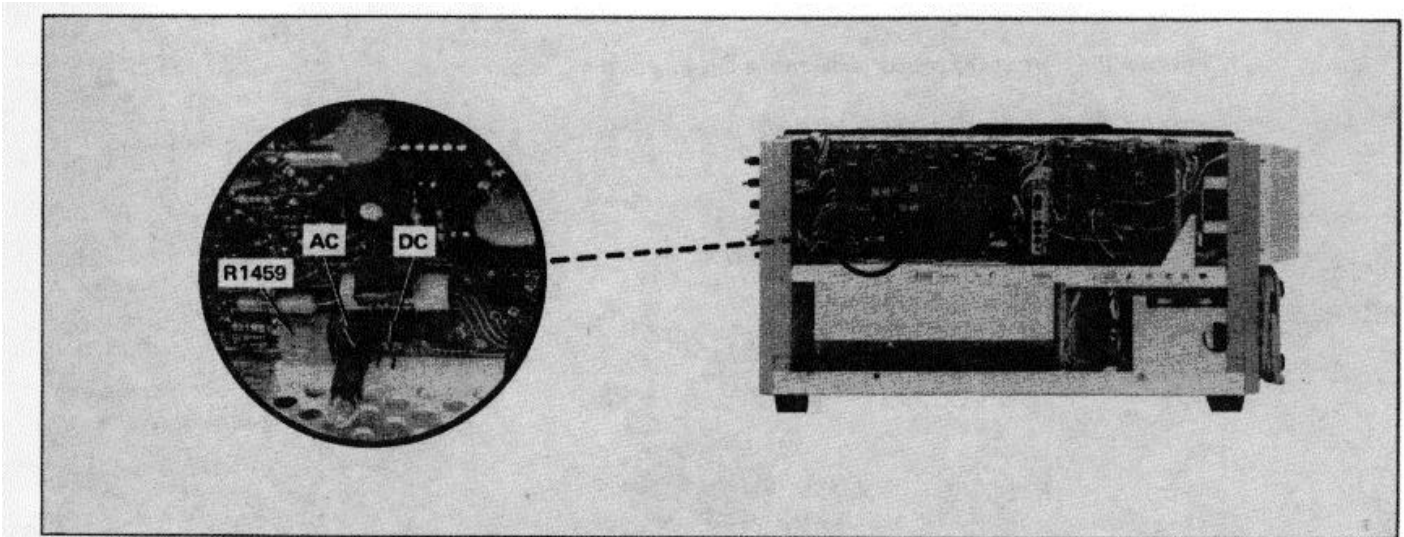

Figure 5-6. Location of Calibrator AC/DC jumper

2. Check Calibrator Repetition Rate

- a. Change jumper P1440 to the AC position (see Figure 5-6)
- b. Install the amplifier unit in the left vertical compartment and the time-base unit in the horizontal compartment
- c. Set the amplifier unit for a deflection factor of one volt/division
- d. Set the time-base unit for auto, internal triggering at a sweep rate of 0.2 millisecond/division
- e. Connect the four-volt calibrator pin-jack to the input of the amplifier unit with the BNC to pin-lack cable
- f. Position the start of the square wave to the left line of the graticule
- g. CHECK-Crt display for length of one complete cycle between 4.2 and 6.3 divisions (one kilohertz $\pm 20\%$)

(A)

(Option 1 deletes this procedure)

F. SIGNALS IN/OUT

Equipment Required:

1. Amplifier units (two)
2. Time-base unit
3. BNC to pin-jack cable
4. Test oscilloscope
5. 5-ohm BNC cable

Before you begin, see **ADJUSTMENT LOCATION** in the Diagrams section.

Control Settings

Preset the 7623A controls as follows:

INTENSITY	Midrange
VERT MODE	LEFT
TRIG SOURCE	VERT MODE
Display Selection	NON STORE
READOUT INTENSITY	Off (n detent)

1. Check REMOTE ERASE

- a. Connect the calibrator signal to the input of the amplifier unit. Obtain a triggered display of two or more divisions.
- b. Press the STORE and VAR PERSIST pushbuttons.
- c. CHECK-That when the REMOTE ERASE input connector is grounded, an erase cycle is generated.
- d. Press the NON STORE pushbutton.

2. Check EXT SS RESET IN

- a. Set the time-base unit to Single Sweep at a sweep rate of 0.5 second/division.
- b. CHECK-That when the EXT SS RESET IN input is grounded, the time-base unit single sweep function is reset.

(A)

Calibration-7623A/R7623A Service

3. Check VERT SIG OUT

- a. Set the time-base unit for auto triggering and adjust the trigger level for a stable display at a sweep rate of one microsecond/division.
- b. Connect a BNC cable to the VERT SIG OUT connector and to the amplifier unit In the right vertical compartment Set TRIG SOURCE to LEFT.
- c. Connect the 0.4-volt CALIBRATOR signal to the input of the amplifier unit in the left vertical compartment Set both vertical amplifiers for a deflection factor of 0.2 volt/division
- d. CHECK-That a two-division signal is displayed by the left vertical amplifier
- e. Set VERT MODE to RIGHT and check that a signal of about five divisions is displayed by the right vertical amplifier
- f. Interchange the connections to the vertical amplifiers Set the TRIG SOURCE to RIGHT
- g. CHECK-That a two-division signal is displayed by the right vertical amplifier
- h. Set the VERT MODE to LEFT and check that a signal of about five divisions is displayed
- i. Install a 50-ohm termination between the cable and the input of the left vertical amplifier
- j. Set the deflection factor of the left vertical to 10 millivolts/division Check for a display of about five divisions
- k. Disconnect all cables

4. Check + SAWTOOTH OUT

- a. Connect the + SAWTOOTH OUT to the Input of the left vertical amplifier Set the deflection factor of the left vertical amplifier for two volts/division.
- b. CHECK-For a sawtooth display of about five divisions in amplitude and greater than 10 centimeters in length

5. Check + GATE OUT

- a. Connect the + GATE OUT to the vertical input of the test oscilloscope and set the deflection factor for two volts/division Set the time/division switch to 1 millisecond/division Set the GATE selector switch to the MAIN GATE position
- b. CHECK-That displayed signal is about five divisions in amplitude

REV B, JUNE, 1976

(Option 7 deletes this procedure)

G. READOUT OPERATION

Equipment Required:	2.	Time-base unit
1. Dual-trace vertical plug-in unit	3.	Three-inch screwdriver

Before you begin, see **ADJUSTMENT LOCATIONS** in the Diagrams section.

Control Settings

Preset the 7623A controls as follows:

INTENSITY	Midrange
READOUT INTENSITY	Midrange
VERT MODE	CHOP
TRIG SOURCE	VERT MODE
Storage Selection	NON STORE

1. Check READOUT Operation

- a. Install the amplier unit, set for dual trace mode, In the left vertical compartment. Push and hold the identify buttons on the amplifier unit.(Switch S2110 should be in the Free-Run (FR) position.) Check that the word IDENTIFY Is within the top division and the bottom division of the graticule Check that the words IDENTIFY are positioned within the left third of the graticule Check completeness of characters without over-scanning (over-scanning causes a bright dot where the traces overlap)
- b. ADJUST-Vertical Separation adjustment R2291 (see Figure 8-23) so the channel 1 characters are within the top division, and the channel 2 characters are within the bottom division of the graticule
- c. ADJUST-Character Height adjustment R2273 (see Figure 8-23) as needed. Characters are typically 0.5 division In height
- d. ADJUST-Character Scan adjustment R2128 (see Figure 8-23) if characters are over-scanned.
- e. Remove the amplifier unit from the left vertical and Install It in the right vertical compartment. Push and hold the Identify buttons on the amplifier unit. Check that the words IDENTIFY are positioned within the center third of the graticule
- f. Remove the amplifier unit from the right vertical and install t in the horizontal compartment Push and hold the identify buttons on the amplifier unit. Check that the words IDENTIFY are positioned within the right third of the graticule.
- g. CHECK-That the correct characters are displayed
- h. ADJUST- Row Match adjustment R2183 (see Figure 8-23) and Column Match adjustment R2214, if necessary, for correct readout display

(A)

Calibration-7623A/R7623A Service

- i. Remove the dual trace plug-in unit

2. Check Readout Gate Trig'd Operation

- a. Set switch S2110 to Gate Trig'd position (see Figure 8-23).
- b. Install the time-base unit in the horizontal plug-in compartment. Set sweep rate to one second/division.
- c. CHECK-That no readout information is displayed till after the sweep At fast sweep rates, this is not noticeable.
- d. Set switch S2110 to FREE RUN position.

REV.B.JUNE.1976

H. STORAGE SYSTEM

Equipment Required:

- | | |
|--------------------------------------|----------------------------|
| 1. Precision dc voltmeter | 9. Time-base unit |
| 2. 100X probe | 10. Three-inch screwdriver |
| 3. Test oscilloscope | |
| 4. Low-frequency signal generator | |
| 5. Medium-frequency signal generator | |
| 6. 10 X probe | |
| 7. 50-ohm BNC cables (two) | |
| 8. Amplifier unit | |

Before you begin, see **ADJUSTMENT LOCATIONS** in the Diagrams section.

Control Settings

Preset the 7623A controls as follows:

VERT MODE	LEFT
TRIG SOURCE	VERT MODE
INTENSITY	Midrange
READOUT INTENSITY	Off (in detent)
Display Selection	NON STORE
ERASE/PERIODIC	CCW (in detent, off)
PERSISTENCE	CCW (maximum)
Storage Selection	BI STABLE
SAVE INTENSITY	CW
STORAGE LEVEL	CW

(A)

Calibration-7823A/R7623A Service

1. Check/Adjust BISTABLE Operation

- a. Install an amplifier unit in the left vertical compartment and a time-base unit in the horizontal compartment.
- b. Set the amplifier unit for a deflection factor of 0.5 volt/division.
- c. Set the time-base unit for auto, internal triggering at a 0.5-millisecond/division sweep rate.
- d. Connect the low-frequency signal generator to the amplifier unit and adjust for 6.4 divisions of display of a 1 kilohertz signal
- e. Set the INTENSITY control for maximum without blooming the trace.
- f. Set the time-base unit for single-sweep operation.
- g. Press STORE.
- h. CHECK-Press the ERASE pushbutton, and check that the sine wave will store anywhere within the center 6 x 8 divisions of the graticule area without fading up or down. This checks the Bistable writing speed at 0.03 division/microsecond. If the conditions given in this check are met, proceed to step 2.
- i. Connect the precision dc voltmeter to the Front Mesh test point (see Fig.8-24).
- j. Press ERASE, and note the meter reading after another waveform has been stored.
- k. Press ERASE, and adjust Bistable Op Level adjustment R1689 (1) for a less-positive meter reading after the erase cycle until part of the stored waveform starts to fade out after about 15 seconds.(It may be necessary to repeat several times to obtain the proper level.)
 - l. Note the meter reading. This is the lower writing threshold.
 - m. Press ERASE, and adjust Bistable Op Level adjustment R1689 (1) for a more-positive meter reading after the erase cycle until part of the stored waveform begins to fade up (trace widening) after about 15 seconds.
 - n. Note the meter reading. This is the upper writing threshold.
 - o. ADJUST-Bistable Op Level adjustment R1689 (1) for a meter reading midway between the upper and lower writing thresholds.
 - p. CHECK-If R1689 (1) was adjusted, recheck the Bistable writing speed (part h of this step)
 - q. Disconnect the voltmeter.

2. Check Periodic Erase

- a. Turn the PERIODIC ERASE knob fully clockwise (minimum time).
- b. CHECK-That erase period is less than or equal to two seconds.

- c. Turn the PERIODIC ERASE knob fully counterclockwise but not into the detent position (maximum time).
- d. CHECK-That the erase period is 10 seconds or greater.
- e. Turn the PERIODIC ERASE knob into the detent position
- f. CHECK-That the display no longer erases automatically.

3. Check SAVE MODE and SAVE INTEN

- a. Press the ERASE pushbutton.
- b. Press the SAVE pushbutton.
- c. Press the ERASE pushbutton.
- d. CHECK-That the display will not erase
- e. CHECK-That the screen goes dark as the SAVE INTEN control is turned counterclockwise (time-base unit Level control must be set for triggered operation).
- f. With the SAVE INTEN control fully counterclockwise, press the STORE pushbutton
- g. Press the SAVE pushbutton.
- h. CHECK-That the waveform display is visible during STORE but goes dark in SAVE
- i. Disconnect the signal generator.

4. Check/Adjust BISTABLE FAST Operation

- a. Press the NON STORE pushbutton
- b. Set the time-base unit for auto, internal triggering at a sweep rate of 0.2 microsecond/division
- c. Connect the medium-frequency signal generator to the amplifier unit.
- d. Set the signal generator for a 6.4-dwlvon display of a 2.5-megahertz signal (writing speed is 50 divisions/microsecond).
- e. Set the INTENSITY control for midrange.
- f. Set the time-base unit for single-sweep operation.
- g. Press the STORE and FAST pushbuttons.
- h. Turn the STORAGE LEVEL control fully clockwise.
- i. Press ERASE. Set the INTENSITY control for the minimum display intensity necessary to store the waveform.

(A)

Calibration-7623A/R7623A Service

- j. CHECK-That the background is slightly fading up (spattered or mottled background).
- k. ADJUST-If necessary, turn the front-panel FAST LEVEL CENTER adjustment to obtain a back- ground that is just beginning to fade up (spatter).
- l. Set the INTENSITY control at the three-o'clock position and the STORAGE LEVEL control at the two-o'clock position.
- m. Press ERASE.
- n. CHECK-That the waveform will store over the center 6 x 8 divisions of the graticule (writing speed is 50 divisions/microsecond).
- o. Press the ERASE pushbutton. Note the quality of the stored trace and background.
- p. Set the time-base unit Level control for nontriggered operation.
- q. Press the ERASE pushbutton Wait one minute, then, trigger the sweep by turning the time-base Level control. If the stored waveform and background are the same as obtained in part o, proceed to step 5
- r. If the waveform and background obtained in part q of this step are not the same as that obtained in part o, connect the precision dc voltmeter to the Fast Mesh test point and set the time-base Level control for nontriggered operation.
- s. If the waveform stored in part q has faded up, press ERASE and adjust Bistable Fast Prep adjustment R1783 (2) for a more-positive meter reading. Repeat parts h through q of this step as necessary to recheck.
- t. If the waveform in part q did not store, press ERASE and adjust Bistable Fast Prep adjustment R1783 (2) for a less-positive meter reading (in about 1-volt steps).Repeat parts h through q of this step a necessary to recheck.
- u. Disconnect the voltmeter and signal generator

5. Check/Adjust VAR PERSIST Operation

- a. Release the FAST pushbutton to the out or off position
- b. Press the NON STORE and VAR PERSIST pushbuttons.
- c. Set the time-base unit for a sweep rate of 20 microseconds/division with auto, internal triggering.
- d. Connect the low-frequency signal generator to the amplifier unit and adjust the amplitude for 6.4 divisions of display of a 2kilohertz signal.
- e. Set the INTENSITY to maximum without trace blooming.
- f. Set the time-base unit for single-sweep operation
- g. Press the STORE pushbutton.

(A)

Calibration-7623A/R7623A Service

h. CHECK-That the signal will store (and can be viewed for at least 30 seconds) In the center 6 x 8 divisions of the graticule area (writing speed is 0.5 division/microsecond).If the conditions given in this check are met, proceed to step 6

i. Set the INTENSITY control fully counterclockwise and the STORAGE LEVEL control fully clockwise.

j. Connect a 10X probe from the test oscilloscope to the Front Mesh test point.

k. Set the test oscilloscope for a one-millisecond/division sweep rate and the vertical for dc input with a deflection factor of 0.5 volt/division (5 volts/division at probe tip).

l. Preset VP Op Level adjustment R1658 (3) for about a -9-volt level on the Front Mesh test point.

m. Adjust VP Prep adjustment R1677 (4), during the erase cycle, for minimum change in voltage level on the Front Mesh test point.(Disregard the pulse at the beginning of the erase cycle.)

n. ADJUST-VP Op Level adjustment R1658 (3) as follows: Push the ERASE pushbutton and observe the dark or shaded areas of the screen

If the screen is bright with no dark or shaded areas, no adjustment is needed.

If dark or shaded area are noticeable, adjust R1658 (3) for a more-positive voltage level (by 5-volt steps) on the Front test point, erase, and observe screen. Repeat until a voltage level is reached where the screen is bright with no shaded areas.

o. Set the STORAGE LEVEL control to the two-o'clock position.

p. Adjust VP Prep adjustment R1677 (4) so that the screen is dark after an erase cycle.

q. ADJUST-VP Prep adjustment R1677 (4) to decrease the Front test point voltage level (during the erase cycle) to the point where, after an erase cycle, approximately 80% of the screen has a light-green back-ground.

r. Repeat parts b through h of this step to recheck.

s. Disconnect the 10X probe and signal generator

6. Check/Adjust VAR PERSIST FAST Operation

a. Press the NON STORE and FAST pushbuttons.

b. Set the time-base unit for auto, internal triggering at a sweep rate of 0.1 microsecond/division.

c. Connect the medium-frequency signal generator to the amplifier unit.

d. Set the signal generator for a 6.4 division display of a 7.5 megahertz signal.

e. Set the INTENSITY control to the three-o'clock position

f. Set the time-base unit for single-sweep operation.

g. Set the STORAGE LEVEL control to the two-o'clock position.

(A)

Calibration-7623A/R7623A Service

- h. Press the STORE pushbutton.
- i. CHECK-Press ERASE, and check that the signal will store (and can be viewed for at least 30 seconds) over the center 6 x 8 divisions of the graticule area (writing speed is 150 divisions/microsecond). If the conditions given in this check are met, proceed to step 7, otherwise, perform the remainder of this step.
- j. Set the time-base unit Level control for nontriggered operation.
- k. Connect the dc voltmeter to the Fast Mesh test point.
- l. Press ERASE.
- m. Adjust VP Fast Prep adjustment R 1779 (6) for a meter reading of +3 volts.
- n. Disconnect the voltmeter
- o. Set the time-base unit Level control for triggered operation.
- p. CHECK-Press ERASE, and check that the background just begins to store. (Background storage is indicated when portions of the background brightness almost match the stored waveform brightness.) Note the quality of the stored waveform.
- q. ADJUST-If necessary, adjust VP Fast Level Offset adjustment R1754 (7) to the point where, after an erase cycle, the background just begins to store. Note the quality of the stored waveform.
- r. Set the time-base unit Level control for nontriggered operation
- s. Press the ERASE pushbutton and wait about 10 seconds before triggering a sweep by turning the time-base Level control
- t. Compare the trace stored in part s with the trace stored immediately after an erase cycle (part p or q, with the time-base Level control set for triggered operation). If the stored waveforms are not similar, perform parts u through z; otherwise proceed to step 7
- u. If the stored waveforms are not similar, connect the dc voltmeter to the Fast Mesh test point
- v. Set the time-base Level control for nontriggered operation.
- w. Press the ERASE pushbutton, and measure the voltage on the Fast Mesh test point (Fast Prep voltage).
- x. If the stored waveform (triggered after 10 seconds) fades up, lower the Fast Prep voltage (in 0.5-volt steps) by adjusting R1779 (6). Check by repeating parts r, s, and t
- y. If parts of the waveform did not store in part t, increase the Fast Prep voltage (in 0.5-volt steps) by adjusting R1779 (6) and check by repeating part r, s, and t
- z. With the STORAGE LEVEL control set at the two-o'clock position, adjust the VP Fast Level Offset adjustment R1754 (7) until the background just begins to store. Repeat part of this step to check writing speed

(A)

7. Check/Adjust VAR PERSIST FAST Stability

- a. Turn the time-base unit Level control trigger a sweep.
- b. Press the ERASE pushbutton.
- c. Turn the time-base unit Level control for nontriggered operation.
- d. Press the ERASE pushbutton.
- e. After one minute, turn the time-base unit Level control to trigger a sweep.
- f. CHECK-Compare the signal transferred up after one minute to that transferred up immediately after the screen is erased when the sweep is triggered. If the stored signals are similar, proceed to part q. If the stored signals are not similar, perform parts g through r.
- g. Connect the dc voltmeter to the Front Mesh test point.
- h. Press the ERASE pushbutton (timebase unit should still be set for single-sweep and untriggered operation).
- i. Turn the timebase unit Level control to trigger a sweep (transfer sweep).
- j. Measure and note the voltage level (Op Level) on the Front Mesh test point.
- k. Set the time-base unit Level control for nontriggered operation.
- l. Press the ERASE pushbutton.
- m. Preset the VP Fast Stability (waiting level) adjustment, R1646 (5) for a voltage level on the Front Mesh 11 volts lower than that measured in part j.
- n. Press the ERASE pushbutton.
- o. After one minute, turn the time-base unit Level control to trigger a sweep.
- p. ADJUST-VP Fast Stability as follows If the background is brighter after the waiting period, increase the measured voltage a small amount by adjusting R1646 (5) and repeat parts a through f to recheck. If the background is darker after the waiting period, decrease the measured voltage a small amount by adjusting R1646 (5) and repeat parts a through f to recheck.
- q. Press the NON STORE pushbutton.
- r. Disconnect all test equipment. This completes the Calibration procedure.

(A)

OPTIONS

The 7623A/R7623A Storage Oscilloscope is available with the following options:

OPTION 1

This option deletes the Readout System. Operation of the instrument is unchanged except there is no alpha-numeric display on the crt.

OPTION3

This option provide electro-magnetic interference (emi) shielding so the instrument will meet the em specification given in Section 2.

OPTION 5

This option provides a special fan to allow operation from 50 Hertz to 400 Hertz line frequency.

OPTION7

This option deletes all rear panel connectors except the EXT Z-AXIS input.

OPTION 12

This option provides fast writing speed t of 200 cm/s stored writing speed. Internal 8X10 (0.9 cm/div) graticule with variable illumination.

REV.B, APR.1975

REPLACEABLE**ELECTRICAL PARTS****PARTS ORDERING INFORMATION**

Replacement parts are available from or through your local Tektronix, Inc. Field Office or representative.

Changes to Tektronix instruments are sometimes made to accommodate improved components as they become available, and to give you the benefit of the latest circuit Improvement developed in our engineering department It is therefore important when ordering parts, to include the following information in your Part number, instrument type or number, serial number, and modification number if applicable.

If a part you have ordered has been replaced with a new or improved part, your local Tektronix, Inc. Field Office or representative will contact you concerning any change in part number

Change information, if any, is located at the rear of this manual.

SPECIAL NOTES AND SYMBOLS

X000	Part first added at this serial number
00X	Part removed after this serial number

ITEM NAME

In the Parts List, an Item Name is separated from the description by a colon (:). Because of space limitations, an Item Name may sometimes appear as incomplete. For further Item Name identification, the U S Federal Cataloging Handbook H1 can be utilized where possible.

ABBREVIATIONS

ACTR	ACTUATOR	PLSTC	PLASTIC
ASSY	ASSEMBLY	QTZ	QUARTZ
CAP	CAPACITOR	RECP	RECEPTACLE
CER	CERAMIC	RES	RESISTOR
CKT	CIRCUIT	RF	RADIO FREQUENCY
COMP	COMPOSITION	SEL	SELECTED
CONN	CONNECTOR	SEMICOND	SEMICONDUCTOR
ELCTLT	ELECTROLYTIC	SENS	SENSITIVE
ELEC	ELECTRICAL	VAR	VARIABLE
INCAND	INCANDESCENT	WW	WIREWOUND
LED	LIGHT EMITTING DIODE	XFMR	TRANSFORMER
NONWIR	NON WIREWOUND	XTAL	CRYSTAL

Electrical Parts Llst-7623A/R7623A Service

CROSS INDEX MFR.CODE NUMBER TO MANUFACTURER

MFR.CODE	MANUFACTURER	ADDRESS	CITY, STATE, ZIP
00853	SANGAMO ELECTRIC CO.,S.CAROLINA DI.	P.O.BOX 128	PICKENS, SC 29671
01121	ALLEN-BRADLEY CO.	1201 2ND ST.SOUTH	MILWAUKEE, WI 53204
01295	TEXAS INSTRUMENTS, INC., SEMICO, DUCTOR GROUP	P.O.BOX 5012	DALLAS, TX 75222
02735	RCA CORP., SOLID STATE DIVISION	ROUTE 202	SOMERVILLE, NY 08876
03508	GENERAL ELECTRIC CO., SEMI-CONDCTOR PRODUCTS DEPT.	ELECTRONICS PARK	SYRACUSE,NY 13201
03877	TRANSITRON ELECTRONIC CORP.	168 ALBION ST.	WAKEFIELD, MA 01880
04713	MOTOROLA, INC., SEMICONDUCTOR PRODUCTS DIV.	5005 E.MCDOWELL RD.	PHOENIX, AZ 85036
05624	BARBER-COLMAN CO.	1300 ROCK ST.	ROCKORD, IL 61101
07263	FAIRCILD SMICONDUCTOR, A DIV.OF FAIRCHILD CAMERA AND INSTRMENT CORP.	464 ELLIS ST.	MOUNTAIN VIEW, CA 94042
07910	TELEDYNE SEMICONDUCTOR	12515 CHADRON AVE.	HAWTHORN., CA 90250
08806	GELECTRIC CO., MINIATURE LAMP PRODUCTS DEPT.	NEA P.	CLEVEAND,OH 44112
12040	NATIONAL SEMICONDUCTOR CORP.	COMMERCE DRIVE	DANBURY, CT 06810
12697	CLAROSTAT MFG.CO., INC.	LOWER WASHINGTON ST.	DOVER, NH 03820
12969	UNITRDE CORP.	580 PLEASAN ST.	WATERTOWN, MA 02172
13715	FAIRCHILD SEMICONDUCTOR, A DIV.OF FAIRCHILD CAMERA AND INSTRUMENT CORP.	4300 REDWOOD HWY.	SAN RAFAEL, CA 94903
14099	SEMTECH CORP.	652 MITCHELL ROD	NEWBURY PARK, CA 91320
1493	CAL-R, INC.	1601 OLYMPIC BLVD.	SANTA MONICA, CA 90404
14752	ELECTCUBE INC.	1710 S.DEL MAR AVE.	SAN GABRIEL, CA 91776
14859	TEXAS INSTRUMENTS, INC.	300 NORH MAIN	VERSAILLES, KY 40383
21845	SOITRON DEVICES, INC., TRANSISTOR DIV.	1177 BLUE HERON BLVD.	RIVIERA BEACH, FL 33404
24931	SPECIALTY CONNECTOR CO., INC.	3560 MADISON AVE.	INDIANAPOLIS, IN 46227
27014	NATIONAL SEMICONDUCTOR CORP.	2900 SAN YSIDRO WAY	SANTA CLARA, CA 95051
50157N	L.INDUSTRIES, IN., ELECTRONICS DEPT.	P.O.BOX 787	MUSKEGON, MI 49443
56289	SPRAGUE ELE CTRIC CO.		NORTH ADAMS, MA 01247
71400	BUSSMAN MFG., DIVISION OF MCGRAW- EDISON CO.	2536 W.UNIVERSITY ST.	ST.LOUIS, MO 63107
71590	NTRALAB ELECTRONICS, DIV.OF GLOBE-UNION, INC.	5757 N.GREEN BAY AVE.	MILWAUKEE, WI 53201
72982	ERIE TECHNOLOGICAL PRODUCTS,INC.	644 W.12TH ST.	ERIE, PA 16512
73138	BECKMAN INSTRUMENTS, INC., HELIPOT DIV.	2500 HARBOR BLVD.	FULLERTON, CA 92634
75042	TRW ELECTRONIC COMPONENTS, IRC FIXED RESISTORS, PHILADELPH IA DIVISION	401 N.BROAD ST.	PHILADELPHIA, PA 19108
76493	BELL INDUSTRIES,INC., MILLER, J.W., DV.	19070 REYES AVE.	COMPTON, CA 90224
77342	AMF, INC., POTTER AND BRUMFIELD DIV.	1200 E.BROADWAY	PRINCETON, IN 47570
79727	C-W INDUSTRIES	550 DAVISVILLE RD.	WARMINSTER, PA 18974
80009	TTRONIX, INC.	P.O.BOX 500	BEAVERTON,OR 97077
80031	ELECTRA-MIDLAND CORP., MEPCO DIV., A NORTH AMERICAN PHILLIPS CO.	22 COLUMBIA RD.	MORRISTOWN,NJ 07960
80294	BOURNS, INC., INSTRUMENT DIV.	6135 MAGNOLIA AVE.	RIVERSIDE, CA 92506
83003	VARO, INC.	800 W.GARLAND AVE.	GARLAND, TX 75040
86684	RCA CORP., ELECTRONIC COPONENTS	415 S.5TH ST.	HARRISON, NJ 07029
90201	MALLORY CAPACITOR CO., DIV.OF P.R.MALLORY CO., INC.	3029 E.WASHINGTON ST.	INDIANAPOLIS, IN 46206
91637	DALE ELECTRONICS, INC.	P.O.BOX 609	COLUMBUS, NB 68601
93410	ESSEX INTERNATIONAL, INC.,CO TIRLS DIV. MANSFILD PLANT	P.O.BOX 1007	MANSFIELD, OH 44903
99942	CENTRAB SEMICONDUCTOR, CENTRALAB ELECTRONICS, DIV.O GLOBE-UNION, INC.	4501 N.ARDEN DR.	EL MONTE, CA 91734

Electrical Parts Llst-7623A/R7623A Service

Ckt No.	Tektronix	Serial/Model No.		Name & Description	Mfr	Mfr Part Number
	Part No.	Eff	Dscont		Code	
A1	670-1956-01			CKT BOARD ASSY:MAIN INTERFACE	80009	670-1956-01
A2	670-1370-04			CKT BOARD ASSY:LOGIC	80009	670-1370-04
A3	670-1371-05			CKT BOARD ASSY:TRIGGER SELECT	80009	670-1371-05
A4	670-3186-00			CKT BOARD ASSY:VERTICAL INTERFACE	80009	670-3186-00
A5	670-3154-02			CKT BOARD ASSY:VERTICAL AMPLIFIER	80009	670-3154-02
A6	670-3017-01			CKT BOARD ASSY:HORIZONTAL AMPLIFIER	80009	670-3017-01
A7	670-1961-00			CKT BOARD ASSY:OUTPUT SIGNALS	80009	670-1961-03
A8	670-3682-00	B010100	B109999	CKT BOARD ASSY:Z-AXIS	80009	670-3682-00
A8	670-3682-01	B110000		CKT BOARD ASSY:Z-AXIS	80009	670-3682-01
A9	670-2844-00	B010100	B049999	CKT BOARD ASSY:ANODE	80009	670-2844-00
A9	670-2844-01	B050000		CKT BOARD ASSY:ANODE	80009	670-2844-01
A10	670-3683-00			CKT BOARD ASSY:HIGH VOLTAGE	80009	670-3683-00
A11	670-1382-05	B010100	B099999	CKT BOARD ASSY:RECTIFIER	80009	670-1382-05
A11	670-1382-06	B10000	B100000	CKT BOARD ASSY:RECTIFIER	80009	670-1382-06
A12	670-1376-10	B010100	B089999	CKT BOARD ASSY:REGULATOR	80009	670-1376-10
A12	670-1376-16	B090000		CKT BOARD ASSY:REGULATOR	80009	670-1376-16
A13	670-1900-03			CKT BOARD ASSY:READOUT	80009	670-1900-03
A14	670-2845-00	B010100	B129999	CKT BOARD ASSY:STORAGE	80009	670-2845-00
A14	670-2845-01	B130000	B159999	CKT BOARD ASSY:STORAGE	80009	670-2845-01
A14	670-2845-02	B160000		CKT BOARD ASSY:STORAGE	80009	670-2845-02
A15	670-1374-00			CKT BOARD ASSY:VERTICAL INTERCONNECT	80009	670-1374-00
A16	670-0702-03			CKT BOARD ASSY:GRATICULE LIGHTS	80009	670-0702-03
A17	670-2847-00			CKT BOARD ASSY:MODE SWITCH	80009	670-2847-00
A18	670-4346-00	XB120000		CKT BOARD ASSY:PROTECTION	80009	670-4346-00
B1001	147-0008-00			MOTOR, AC:115SVAC RMS, 60HZ	05624	AYAA13080
B1001 ¹	119-0396-00			FAN, TUBEAXIAL:50-400HZ, 115V, AC	92702	MBC2206F6
C1	290-0271-00			CAP., FXD, ELCTLT:9UF, +20-15%, 125V	56289	109D905C2125F2
C3	290-0302-00			CAP., FXD, ELCTLT:100UF, 10%, ZOV	12954	D100DZOKI
C5	290-0302-00			CAP., FXD, ELCTLT: 100UF, L10%, 20V	12954	D100DO20KI
C7	290-0302-00			CAP., FXD, ELCTLT:100UF, 10%, 20V	12954	D100D20KI
C9	290-0271-00			CAP., FXD, ELCTLT.9UF, +20-15%, 125V	56289	109D905C2125F2
C16	283-0068-00			CAP., FXD, CER DI:0.01UF, +100-0%, 500V	56289	19C241
C18	283-0068-00			CAP., FXD, CER DI 0.01UF, +100-0%, 500V	56289	19C241
C44	283-0081-00			CAP., FXD, CER DI:0.1UF, +80-20%, 25V	56289	36C600
C48	283-0081-00			CAP., FXD, CER DI:0.1UF, +80-20%, 25V	56289	36C600
C55	283-0003-00			CAP., FXD, CER DI:0.01UF, +80-20%, 150V	72982	855-558Z5U-103Z
C58	283-0003-00			CAP., FXD, CER DI:0.01UF, +80-20%, 150V	72982	855-558ZSU-103Z
C59	283-0672-00			CAP., FXD, MICA D:0200PF, I%, 500V	00853	D155F201FO
C60	281-0564-00			CAP., FXD, CER DI:24PF, 5%, 500V	72982	301-0000COG0240J
C67	281-0605-00			CAP., FXD, CER DI:200PF, 10%, 500V	04222	7001-1375
C76	283-0000-00			CAP., FXD, CER DI:0.001UF, +100-0%, 500V	72982	831-516E102P
C89	283-0003-00			CAP., FXD, CER DI:0.1UF, +80-20%, 150V	72982	855-558Z5U-103Z
C136	281-0547-00			CAP., FXD, CER DI:2.7PF, 10%, 500V	72982	301-000COJ0279C
C137	283-0000-00			CAP., FXD, CER DI:0.001UF, +100-0%, 500V	72982	831-516E102P
C138	281-0503-00			CAP., FXD, CER DI:8PF, +/-0.5PF, 500V	72982	301-000COH0809D
C146	281-0547-00			CAP., FXD, CER DI:2.7PF, 10%, 500V	72982	301-000COJ0279C
C148	281-0503-00			CAP., FXD, CER DI:BPF, +/-0.5PF, 500V	72982	301-000COH0809D
C149	283-0000-00			CAP., FXD, CER DI:0.001UF, +100-0%, 500V	72962	831-516EL02P
C152	283-0000-00			CAP., FXD, CER DI:0.001UF, +100-0%, 500V	72982	831-516E102P
C166	281-0547-00			CAP., FXD, CER DI: 2.7PF, 10%, 500V	72982	301-000COJ0279C
C168	281-0503-00			CAP., FXD, CER DI: 8PF, +/-0.5PF, 500V	72982	301-000COH0809D
C193	283-0026-00			CAP., FXD, CER DI:0.2UF, +80-20%, 25V	56289	274C3
C195	283-0003-00			CAP., FXD, CER DI:0.01UF, +80-20%, 150V	72982	855-558ZSU-103Z
C196	283-0026-00			CAP., FXD, CER DI:0.2UF, +80-20%, 25V	56289	274C3
C198	283-0026-00			CAP., FXD, CER DI:0.2UF, +80-20%, 25V	56289	274C3
C301	283-0003-00			CAP., FXD, CER DI:0.01UF, +80-20%, 150V	72982	855-558ZU-103Z
C305	283-0004-00			CAP., FXD, CER DI:0.02UF, +80-20%, 150V	72982	855-558-Z5V0203Z
C322	281-0572-00			CAP., FXD, CER DI:6.8PF, +/-0.5PF, 500V	72982	301-000COH0689D
C329	281-0572-00			CAP., FXD, CER DI:6.8PF, +/-0.5PF, 500V	72982	301-000COH0689D

¹ Option 5 only.

REV&.G AUG.1977

Electrical Parts Llst-7623A/R7623A Service

Ckt No.	Tektronix	Serial/Model No.		Name & Description	Mfr	Mfr Part Number
	Part No.	Eff	Dscont		Code	
C342	283-0000-00			CAP., FXD, CER DI:0.001UF, +100-0%, 500V	72982	831-516E102P
C348	283-0000-00			CAP., FXD, CER DI:0.001UF, +100-0%, 500V	72982	831-516E102P
C545	281-0550-00			CAP., FXD, CE DI:120PF, 10%, 500V	72982	301-000XSP0121K
C552	283-0002-00			CAP., FXD, CER DI:0.01UF, +80 -20%, 500V	72982	811-546E103Z
C555	283-0083-00			CAP., FXD, CER DI:0.0047UF, 20, 500V	72982	811-565C472J
C56	281-0064-00			CAP., VAR, PLSC:0.25-1.5PF, 600V	72982	530-002
C711	283-0002-00			CAP., FXD, CER DI:0.01UF, +80-20%, 500V	72982	811-546E103Z
C574	283-0002-00			CAP., FXD, CER DI:0.01UF, +80-20%, 500V	72982	811-546E103Z
C575	283-3-00-00			CAP., FXD, CER DI 0.0047UF, 20%, 500V	72982	811-565C472J
C584	281-0546-00			CAP., FXD, CER DI 330PF, 10%, 50V	72982	301-000XSP0331K
C586	281-0064-00			CAP., VAR, PLSTC:0.25-1.5PF, 600V	72982	530-002
C588	281-0091-00			CAP., VAR, CER DI.2-8PF	72982	538-011-89A
C591	283-0002-00			CAP., FM, CER DI:0.01UF, +80 -20%, 50V	72982	811-546E103Z
C593	283-0002-00			CAP., FXD, CER DI:0.01UF, +80-20, 5000V	72982	811-546E103Z
C595	283-0081-00			CAP., FXD, CER DI:0.1UF, +80-20%, 25V	56289	36C600
C597	283-0081-00			CAP., FX, CER DI:0.1UF, +80-20%, 25V	586289	36C600
C598	283-0111-00	B010100	B149999	CAP., FXD, CER DI:0.1UF, 20%, 50V	72982	8121-N088Z5U1104
C598	283-0178-00	B150000		CAP., FXD, CER DI 0.1UF, +80-20%, 100V	72982	8131N145 E 104Z
C599	283-0081-00			CAP., FXD, CER DI:0.1UF, +80-20%, 25V	56289	36C600
C605	281-0612-00	B010100	B19999	CAP., FXD, CER DI:5.6PF, +/-O.SPF, 500V	72982	374-001C0H0569D
C605	281-0584-00	B120000		CAP., FXD, CER DI:100PF, 5%, 500V	72982	301-000Y5D0101J
C610	283-0000-00			CAP., FXD, CER DI:0.001UF, +100-0%, 500V	72982	831-516E102P
C615	281-0513-00			CAP., FXD, CER DI 27PF, +/-5.4PF, 500V	72982	301-000P2G0270M
C619	283-0000-00			CAP., FXD, CER DI:0.001UF, +100-0%, 500V	72982	831-516E102P
C622	283-0003-00			CAP., FXD, CER DI:0.01UF, +80-200%, 150V	72982	855-547E03Z
C637	281-0510-00			CAP., FXD, CER DI:22PF, +/-4.4PF, 500V	72982	301-000C0G0220M
C639	283-0111-00			CAP., FXD, CER DI:0.1UF, 20%, 50V	72982	8131N075651104M
C643	283-0111-00			CAP., FXD, CER DI:0.1UF, 20%, 50V	72982	8131N075651104M
C662	283-0080-00			CAP., FXD, CER DI:0.022UF, +80-20%, 25V	56289	19C611
C667	283-0000-00			CAP., FXD, CER DI:0.001UF, +100-0%, 500V	72982	831-516E102P
C669	283-0111-00			CAP., FXD, CER DI:0.1UF, 20%, 50V	72982	8131N075651104M
C679	283-0111-00			CAP., FXD, CER DI:0.1UF, 20%, 50V	72982	8131N075651104M
C806	290-0468-00			CAP., FXD, ELCTLT: 25UF, +75-10%, 150V	56289	68D10470
C808	290-0507-00			CAP., FXD, ELCTLT 1800F, +75-10%, 75V	56289	68D10472
C809	290-0507-00			CAP., FXD, ELCTLT 1800UF, +75-10%, 75V	56289	68D10472
C810	285-0555-00			CAP., FXD, PLSTC:0.1UF, 20%, 100V	56289	410P10401
C811	290-0581-00			CAP., FXD, ELCTLT:14, 000UF, +75-10%, 25V	56289	6-D10489
C813	290-0506-00			CAP., FXD, ELCTLT:9600UF, +100-10%, 25V	56289	6D10471
C814	290-0506-00			CAP., FXD, ELCTLT:9600UF, +100-10%, 25V	56289	68D10471
C820	285-0555-00			CAP., FXD, PLSTC:0.1UF, 20%, 100V	56289	410P10401
C821	290-0508-00			CAP., FXD, ELCTLT:18, 000UF, +100-1%, 15V	56289	68D10444
C823	283-0004-00			CAP., FXD, CER DI:0.02UF, +80-20%, 15V	72982	855-547E203Z
C827	283-0077-00			CAP., FXD, CER DI:330PF, 5%, 500V	56289	40C94A3
C858	283-0078-00			CAP., FXD, CER DI:0.001UF, 20%, 50W	56289	20C114A8
C866	283-0078-00			CAP., FXD, CER DI:0.001UF, O20, 500V	56289	20C114A8
C876	283-0328-00			CAP., FXD, CER DI:0.03UF, +804 B%, 200V	72982	813IN225651303Z
C880	283-0638-00			CAP., FXD, MICA D:13PF, 1 %, 100V	00853	D151E131F0
C889	290-0415-00			CAP., FXD, ELCTLT:5.6UF, 10%, 35V	56289	150D565X9035B
C923	281-0591-00			CAP., FXD, CER DI:5600PF, 20%, 200V	72982	3930-O1Z5V0562Z
C936	283-0178-00			CAP., FXD, CER DI:0.1UF, +80-20%, 100V	72982	813N145651104Z
C943	283-0078-00			CAP., FXD, CER DI:0.001UF, 20%, 500V	56289	20C114A8
C950	283-0083-00			CAP., FXD, CER DI:0.0047UF, 20, 500V	72982	811-565C472J
C975	283-0000-00			CAP., FXD, CER DI:0.001UF, +100-0%, 500V	72982	831-516E102P
C979	281-0591-00			CAP., FXD, CER DI:5600PF, 20%, 200V	72982	3930-01ZSV0562Z
C985	283-0083-00			CAP., FXD, CER DI:0.0047UF, 20%, 500V	7298	811-565C472J
C1002 ¹	285-0562-00			CP., FXD, CER DI:0.47400V	56289	410P47404

¹Option 5 only

Ckt No.	Tektronix Part No.	Serial/Model No. Eff	Dscont	Name & Description	Mfr Code	Mfr Part Number
C1107	283-0003-00			CAP., FXD, CER DI:0.01UF, +80-20%, 15V	72982	855-558ZSU-103Z
C1109	283-0004-00			CAP., FXD, CER DI:0.02UF, +80-20%, 150V	72982	855-558-ZSV0203Z
C1115	281-0064-00			CAP., VAR, PLSTC:.25-1.5PF, 600V	72982	530-002
C1120	283-0004-00	B010100	B149999	CAP., FXD, CER DI:0.02UF, +80-20%, 150V	72982	855-558-Z5V0203Z
C1120	283-0068-00	B150000		CAP., FXD, CER DI:0.01UF, +100-0%, 500V	56289	19C241
C1124	283-0004-00	B010100	8149999	CAP., FXD, CER DI:0.02ZUF, +80-20%, 150V	72982	855-558-Z5V0203Z
C1124	283-0068-00	B150000		CAP., FXD, CER DI:0.01UF, +100-0%, 500V	56289	19C241
C1127	283-0111-00			CAP., FXD, CER DI:0.1UF, 20%, 50V	72982	8121-N088ZSU104M
C1158	281-0512-00			CAP., FXD, CER DX:27PF, +/-2.7PF, 500V	72982	308-000C0G0270K
C1159	281-0064-00			CAP., VAR, PLSTC:0.25-1.SPF, 600V	72982	530-002
C1163	283-0004-00	B010100	8109999	CAP., FXD, CER DI:0.02UF, +020%, 150V	72982	855-558-ZSV0203Z
C1163	283-0068-00	B110000		CAP., FXD, CER DI:0.01UF, +100-0%, 500 V	56289	19C241
C1164	283-0057-00			CAP., FXD, CER DI:0.1UF, +80-20%, 200V	56289	274CI10
C1168	283-0111-00	B010100	8149999	CAP., FXD, CER DI:0.1UF, 20%, 50V	72982	8121-NO88Z5U104M
C1168	283-0178-00	B150000		CAP., FXD, CER DI:0.1.WUF, +D-200%, 100V	72982	8131N145 E 104Z
C1185	281-0524-00			CAP., FXD, CER DI:150PF, +/-30PF, 500V	04222	7001-1381
C1193	285-0629-00			CAP., FXD, PLSC:0.047UF, 20%, 100V	56289	410P47301
C1198	290-0287-00			CAP., FXD, ELCTLT47UF, 20%, 25V	56289	30D476X0025CC4
C1201	283-0345-00			CAP., FXD, CER DI:1000PFD, 10%, 10, 000V	72982	3910BW324XR1102Z
C1202	283-0345-00			CAP., FXD, CER DI:1000PF, 10%, 10, 000V	72982	3910BW324XS02Z
C1206	283-0345-00			CAP., FXD, CER DI:10PF, 10%, 10, 000V	72982	3910BW324XS R102Z
C1213	283-0082-00			CAP., FXD, CER DI:0.01UF, +80-20%, 4000V	56289	112C29
C1214	283-0082-00			CAP., FXD, CER DI:0.01UF, +80-20%, 4000V	56289	112C29
C1219	285-1077-00			CAP., FXD, PLS.C:O.UF, 20%, 600V	14752	230B1F104
C1224	290-0135-00			CAP., FXD, ELCTLT: 15UF, 20%, V	56289	150D156X0020B
C1225	283-0203-00			CAP., FXD, CER DI:0.47UF, 20%, 50V	72982	8131N075 E47Q4
C1228	283-0271-00			CAP., FXD, CER DI:Z.001UF, 20, 4000V	56289	33C325
C1232	290-0164-00			CAP., FXD, ELCTLT:1UF, +50-101, 150V	56289	30D105F150BA2
C1235	281-0513-00			CAP., FXD, CER DI:27PF, +/-5.4PF, 500V	72982	301-000PzG0270m
C1237	283-0271-00			CAP., FXD, CER DI:0.001UF, 20%, 4000V	56289	33C325
C1238	283-0271-00			CAP., FXD, CER DI:0.01UF, 20%, 4000V	56289	33C325
C1240	283-0013-00			CAP., FXD, CER DI:0.01UF, +100-0, 1000V	56289	33C29A7
C1245	283-0003-00			CAP., FXD, CER DI:0.01UF, +80-20%, 150V	72982	855-558ZSU-103Z
C1250	290-0164-00			CAP., FXD, ELCTLT:UF, +50-10%, 150V	56289	30D105F150BA
C1253	281-0513-00			CAP., FXD, CER DI:27PF, +/-5.4PF, 500V	72982	301-000P2G0270M
C1255	283-0261-00			CAP., FXD, CER DI:0.1UF, 20%, 4000V	56289	41C421
C1256	283-0271-00			CAP., FXD, CER DI:0.001UF, 20%, 4000V	56289	33C325
C1263	281-0543-00			CAP., FXD, CER DI:270PF, 10%, 500V	72982	301055XSP271K
C1264	283-0271-00			CAP., FXD, CER DI:0.001UF, 20%, 4000V	56289	33C325
C1270	283-0003-00			CAP., FXD, CER DI:0.1UF, +80-20%, 150V	72982	855-558Z5U -1032
C1273	283-0003-00			CAP., FXD, CER DI:0.01UF, +80-20%, 150V	72982	855-558Z5U-103Z
C1292	283-0003-00			CAP., FXD, CER DI:0.1UF, +80-20%, 150V	72982	855-558Z5U-103Z
C1415	283-0003-00			CAP., FXD, CER DI:0.11UF, +80-20%, 150V	72982	855-558Z5U-103Z
C1424	290-0530-00			CAP., FXD, ECTLT:68UF, 20D , 6V	90201	TDC686M06NLF
C1444	285-0703-00			CAP., FXD, PLSTC:0.1UP, 5%, 10V	56289	410PI12
C1461	281-0605-00			CAP., FXD, CER DI:200PF, 10, 500V	04222	7001-1375
C1476	283-0058-00			CAP., FXD, CER DI:0.027UF, 10%, 100V	72982	8131NI47W5R273K
C1491	283-0041-00			CAP., FXD, CER DI:0.0033UF, 5%, 500V	72982	841-541B332J
C1501	283-0003-00			CAP., FXD, CER DI:0.01UF, +80-20%, 150V	72982	855-558ZSU-103Z
C1517	290-0114-00	B010100	B129999	CAP., FXD, ELCTLT:47UF, 20%, 6V	56289	150D476X0006B2
C1517	290-0297-00	B130000		CAP., FXD, ELCTLT: 39UF, 10%, , 10V	56289	1501D396X901082
C1524	283-0003-00			CAP., FXD, CER DI:0.01UF, +80-20%, 150V	72982	855-558Z5U-103Z
C1534	283-0111-00			CAP., FXD, CER DI:0.ZUF, 20%, 50V	72982	6121-N088Z5U104M
C1537	283-0111-00			CAP., FXD, CER DI:0.1UF, 20%, 50V	72962	8121-N088Z5U104M
C1542	283-0111-00			CAP., FXD, CER DI:0.1UF, 20%, 50V	72982	8121-NO88Z5U104M
C1544	290-0297-00			CAP., FXD, ELCTT:39UF, 10%, 10V	56289	150D396X90102
C1548	290-0297-00			CAP., FXD, ELCTLT: 39UF, 10%, 1	56289	150D396X9010B2
C1550	281-0519-00			CAP., FXD, CER DI:47PF, +/-4.7PF, 500V	72982	308-000C0G0470K

Ckt No.	Tektronix Part No.	Serial/Model No. Eff Dscont	Name & Description	Mfr Code	Mfr Part Number
C1565	283-0003-00		CAP., FXD, CER DI:0.01UF, +80-20%, 150V	72982	855-558Z5U-103Z
C1574	283-0059-00		CAP., FXD, CER DI:1UF, +80-20%, 25V	72982	8141N038E105Z
C1580	281-0605-00	B010100 B129999	CAP., FXD, CER DI:2000PF, 10, 500V	04222	7001-1375
C1580	283-0023-00	B130000	CAP., FXD, CER DI:0.1UF, +80-20%, 2V	91418	MX104Z1201R0
C1583	283-0059-00		CAP., FXD, CER DI:1UF, +80-20, 25V	72982	8141N038E105Z
C1597	283-0003-00		CAP., FXD, CER DI:0.01UF, +80-20%, 150V	72982	855-558Z5U-103Z
C1601	290-0114-00		CAP., FXD, ECTLT:47UF, 20%, 6V	56289	150D476X0006B2
C1606	283-0003-00		CAP., FXD, CER DI:0.01UF, +80-20, 150SV	72982	855-558Z5U-103Z
C1608	290-0114-00		CAP., FXD, ELCTLT:47UF, 20, 16V	56289	150D476X0006B2
C1611	290-0297-00		CAP., FXD, ELCTLT39UF, 10%, 10V	56289	150D396X9010BZ
C1614	283-0088-00	B010100 B129999	CAP., FXD, CER DI:1100PF, 5%, 50V	56289	20C285
C1614	283-0116-00	B130000	CAP., FXD, CER DI:820PP, 5%, 500500V	72982	801-547BB21J
C1622	290-0244-00		CAP., FXD, ELCTLT: 0.47UF, 5%, 35V	56289	162D474X5035BC
C1636	283-0150-00		CAP., FXD, CER DI:650PF, 5%, 200V	72982	835-515B651
C1637	281-0584-00		CAP., FXD, CER DI:10PF, 5%, 500V	72982	301-00YSD101J
C1678	283-0065-00		CAP., FXD, CER DI:0.001UF, 5, 100V	72982	805-505B102J
C1695	290-0187-00		CAP., FXD, ETCTLT:4.7UF, 20%, 35V	56289	150D475X0035B
C1703	283-0003-00		CAP., FXD, CER DI:0.01UF, +80-20, 150V	72982	855-558Z5U-103Z
C1707	283-0111-00	B0 10100 B149999	CAP., FXD, CER DI:0.1UF, 20%, 5DV	72982	8121-N088Z5U104M
C1707	283-0178-00	B150000	CAP., FXD, CER DI:0.1UF, +80-20%, 100V	72982	8131N145 E 104Z
C1711	283-0003-00		CAP., FXD, CER DI:0.001UF, +80-200%, 150V	72982	855-558Z5U-103Z
C1713	281-0557-00	B010100 B159999	CAP., FXD, CER DI.1.8PF, 10%, 500V	72982	301-000C0K0189B
C1713	281-0661-00	B160000	CAP., FXD, CER DI:0.8PF, +/-0.1PF, 500V	72982	301-000C0K0808B
C1730	281-0523-00		CAP., FXD, CER DI.100PF, +/-20PF, 500V	72962	301-000U2M0101M
C1731	281-0523-00		CAP., FXD, CER DI:100PF, +/-20PF, 500V	72982	301-00UZ2M0101M
C1736	290-0 L 64-00		CAP., FXD, ELCTLT:UF, +50-10%, 150V	56289	30D105F150A2
C1793	283-0003-00		CAP., FXD, CER DI:0.01UF, +80-20%, 150V	72982	855-558Z5U-103Z
C1793	283-0111-00		CAP., FXD, CER DI:0.UF, 20%, 50V	72982	8121-N088ZSU14M
C1796	283-0000-00		CAP., FXD, CER DI:0.001UF, +100-00%, 500V	72982	831-516E02P
C1798	283-0092-00	B010100 B149999	CAP., FXD, CER DI:0.03UF, +80-20%, 200V	72982	845-534E303Z
C1798	283-0006-00	Bf50000	CAP., FXD, CER DI:0.02UF, +80-20%, 500V	72982	841-54IEZ03Z
C1823	281-0523-00	XB150000	CAP., FXD, CER DI:100PF, +/-20PF, 500V	72982	301-00U2M0101M
C1831	283-0092-00	B010100 B149999	CAP., FXD, CER DI:0.03UF, +80-20%, 200V	72982	845-534E303Z
C1831	283-0006-00	B150000	CAP., FXD, CER DI:0.02UF, +80-20%, 500V	72982	841-541E203Z
C1838	283-0000-00		CAP., FXD, CER DI:0 01UF, +100-0%, 500V	72982	831-516E102P
C1925	290-0536-00		CAP., FXD, ELCTLT:10UF, 20%, 25V	90201	TD106M025FL
C1926	290-0535-00		CAP., FXD, ELCTLT:33UF, 20%, 10V	56289	196D336X0010KA1
C1948	285-1077-00		CAP., FXD, PLSTC:0.10UF, 20%, 600V	14752	230B1F104
C1981	283-0092-00	010100 8149999	CAP., FXD, CER DI:0.03UF, +80-20%, 200V	72982	845-534E303Z
C1981	283-0006-00	B150000	CAP., FXD, CER DI:0.02UF, +80-20%, 500V	72982	841-541E203Z
C1983	283-0111-00		CmP., FXD, CER DI:0.1UFW20%, 50V	72982	8121-N088Z5U104M
C1985	290-0531-00		CAP., FXD, ECTLT:100UF, 20, 10V	90201	TDC107M010WLC
C1987	283-0111-00		CAP., FXD, CER DI:0.1UF, 20%, 50V	72982	8121-N088ZSU104M
C1989	283-0111-00	B010100 B149999	CAP., FXD, CER DI:0.1UF, 20%, 50V	72982	8121-N088ZSU104M
C1989	283-0178-00	B150000	CAP., FXD, CER DI.0.1UF, +80-20%, 100V	72982	8131NI45 E 104Z
C2101	283-0004-00		CAP., FXD, CER DI:0.02UF, +80-20%, 150V	72982	855-558-Z5V0203Z
C2109	283-0003-00		CAP., FXD, CER DI:0.01UF, +80-20, 150V	72982	855-558ZSU-103Z
C2112	283-0077-00		CAP., FXD, CER DI:330PF, 5%, 500V	56289	40C94A3
C2115	290-0534-00		CAP., FXD, ELCTLT- 1UF, 20, 35V	56289	196D105X0035HA1
C2117	290-0534-00		CAP., FXD, ELCTLT: 1UF, 20%, 35V	56289	196D105X0035HA1
C2119	290-0534-00		CAP., FXD, ECTLT: 1UF, 20%, 35V	56289	196D105X0035HA1
C2121	283-0594-00		CAP., FXD, MICA D:0.001UF, 1%, 100V	00853	D151F102F0
C2135	285-0698-00		CAP., FXD, PLSTC:0 .008UF, 5, 100V	56289	410P82251
C2140	283-0103-00		CAP., FXD, CER DI:180PF, 51, 500V	56289	40C638
C2144	281-0544-00		CAP., FXD, CER DI:5.6PF, 10%, 500V	72982	301-000C0H0569D
C2145	290-0534-00		CAP., FXD, ELCTLT:1UF, 20%, 35V	56289	196D105X0035HA1
C2155	283-0103-00		CP., FXD, CER DI:180PF, 5%, 500V	56289	40C638
C2183	283-0032-00		CAP., FXD, CER DI:470PF, 5%, 500V	72982	831-500Z5D471J
C2185	283-0004-00		CAP., FXD, CER DI:0.02UF, +80-20%, 150V	72982	855-558-Z5V0203Z
C2214	283-0032-00		CAP., FXD, CER DI:470PF, 5%, 500V	72982	831-500Z5D471J
C2242	283-0000-00		CAP., FXD, CER DI:0.001UF, +100-0%, 500V	72982	831-516E102P
C2244	283-0004-00		CAP., FXD, CER DI:0.02UF, +80-20%, 150V	72982	855-558-Z5V0203Z

Ckt No. Number	Tektronix		Serial/Model No.		Name & Description	Mfr Code	Mfr Part
	Part No.	Eff	Dscont				
C2255	283-0000-00				CAP., FXD, CER DI:0.001UF, +100-0%, 500V	72982	831-516E102P
C2281	283-0054-00	XB030270			CAP., FXD, CER D150PF, 5%, 200V	72982	855-535U21511J
C2341	283-0177-00				CAP., FXD, CER DI:1UF, +80-20%, 150V	72982	8131N039651105Z
C2345	283-0159-00				CAP., FD, CER DI:18PF, 5%, 50V	72982	8111A058COG180J
C2347	281-0627-00				CAP., FXD, CER DI:1PF, +/-0.25PF, 500V	72982	301-000C0G0109C
C2348	283-0185-00				CAP., FD, CER DI:2.5PF, 5%, 50V	72982	8101A058C0K259B
C2355	283-0159-00				CAP., FXD, CER DI:18PF, 5%, 50V	72982	8111A058C0G180J
C2357	281-0627-00				CAP., F, CER DI: 1PF, +/-0.25PF, 00V	72982	301- 000C0G0109C
C2358	283-0185-00				CAP., XD, CER DI:2.5PF, 5%, 50V	72982	8101A058C0K259B
C2366	281-0562-00				CAP., FD, CER DI:39PF, 10%, 500V	72982	301- 000U2J0390K
C2376	281-0562-00				CAP., F, CER DI:39PF, 10%, 500V	72982	301-000U2J0390K
C2387	281-0509-00				CAP., FXD, CER DI:15PF, +/-1.5PF, 500V	72982	301-000C0G0150K
C2397	281-0509-00				CAP., FD, CER DI D15PF, +/-1.5PF, 500V	72982	301- 000C0G0150K
C2403	283-0003-00				CAP., F, CER DI:0.01U, +80-20%, 150V	72982	855-547E103Z
C2409	283-0077-00				CAP., FXD, CER DI:330PF15, 5, 00V	56289	40C94A3
C2411	281-0564-00				CAP., FXD, CER DI24PF, 5, 500V	72982	301-000C0G0240J
C2416	281-0123-00				CAP., VAR, CER DI:5-2PF, 100V	72982	518-000A5-25
C2418	281-0158-00				CAP., VAR, CER DI:7-45PF, 50V	72982	518- 000G7-45
C2429	283-0000-00				CAP., FXD, CER DI:0.001UF, +100-0, S00V	72982	831-516E102P
C2445	283-0000-00				CAP., FXD, CER DI:0.001UF, +100-0, 500V	72982	831-516EL02P
C2448	281-0661-00				CAP., FXD, CER DI:0.8P, +/-0.1PF, 500V	72982	301-000C0G0808B
C2456	281-0122-00				CAP., VAR, -ER DI:2.5-9PF, 100	72982	518-000A2.5-9
C2465	283-0103-00				CAP., FXD, CER DI:180PF, 5%, 500V	56289	40C638
C2469	281-0167-00				CAP., VAR, CER DI:9-45PF, 200V	72982	538-011-D 9-45
C2509	283-0649-00			CAP., FXD, MICA D:105PF, 1%, 300V	00853	D153F1050F0	
C2511	281-0205-00			CAP., VAR, PLSTC:5.5-65PF, 0100V	80031	C010GA/60E	
C2524	283-0000-00			CAP., FXD, CER DI:0.001UF, +100-0%, 500V	72982	831-516E102P	
C2545	283-0000-00			CAP., FXD, CER DI:0.001UF, +100-0%, 500V	72982	831-516E102P	
C2548	281-0661-00			CAP., FXD, CER DI:0.8PF, +/-0.1PF, 500V	72982	301-000C0G0808B	
C2565	283-0103-00			CAP., FD, CER DI:180PF, 5%, 500V	56289	40C638	
C2593	283-0111-00	B010100 B149999 B150000			CAP., FXD, CER DI:0.1UF, 20%, 50V	72982	8121-N088ZSU104M
C2593	283-0178-00				CAP., FXD, CER DI:0.1UF, +80-20%, 100V	72982	8131N145 E 104Z
C2595	290-0527-00			CAP., F, ELCTLT:15UF, 20%, 20V	90201	TDC156M020NLF	
C2597	290-0527-00			CAP., FXD, ELCTLT:15UF, 20%, 20V	90201	TDC156M020NLF	
CR26	152-0141-02			SEMICOND DEVICE:SILICON, 30V, 150MA	07910	1N4152	
CR27	152-0141-02			SEMICOND DEVICE:SILICON, 30V, 150MA	07910	1N4152	
CR33	152-0141-02			SEMICOND DEVICE:SILICON, 30V, 150MA	07910	1N4152	
CR44	152-0141-02			SEMICOND DEVICE:SILICON, 30V, 150MA	07910	1N4152	
CR48	152-0141-02			SEMICOND DEVICE:SILICON, 30V, 150MA	07910	1N4152	
CR84	152-0333-00			SEMICOND DEVICE:SILICON, 55V, 200MA	80009	152-0333-00	
CR85	152-0333-00			SEMICOND DEVICE:SILICON, 55V, 200MA	80009	152-0333-00	
CR93	152-0141-02			SEMICOND DEVICE:SILICON, 30V, 150MA	07910	1N4152	
CR124	152-0141-02			SEMICOND DEVICE:SILICON, 30V, 150MA	07910	1N4152	
CR125	152-0141-02			SEMICOND DEVICE:SILICON, 30V, 150MA	07910	114152	
CR126	152-0141-02			SEMICOND DEVICE:SILICON, 30V, 150MA	07910	1N4152	
CR130	152-0141-02			SEMICOND DEVICE:SILICON, 30V, 150MA	07910	1N4152	
CR140	152-0141-02			SEMICOND DEVICE:SILICON, 30V, 150MA	07910	1N4152	
CR155	152-0141-02			SEMICOND DEVICE:SILICON, 30V, 150MA	07910	1N4152	
CR160	152-0141-02			SEMICOND DEVICE:SILICON, 30V, 150MA	07910	1N4152	
CR341	152-0141-02			SEMICOND DEVICE:SILICON, 30V, 150MA	07910	1N4152	
CR349	152-0141-02			SEMICOND DEVICE:SILICON, 30V, 150MA	07910	1N4152	
CR530	152-0153-00			SEMICOND DEVICE:SILICON, 15V, 50MA	13715	FD7003	
CR531	152-0141-02			SEMICOND DEVICE:SILICON, 30V, 150MA	07910	1N4152	
CR532	152-0141-02			SEMICOND DEVICE:SILICON, 30V, 150MA	07910	1N4152	

Ckt No. Number	Tektronix	Serial/Model No.		Name & Description	Mfr	Mfr Part
	Part No.	Eff	Dscont		Code	
CR533	152-0153-00			SEMICON D DEVICE:SILICON, 15V, 50MA	13715	FD7003
CR543	152-0141-02			SEMICON D DEVICE:SILICON, 30V, 150MA	07910	1N4152
CR544	152-0141-02			SEMICON D DEVICE:SILICON, 30V, 150MA	07910	1N4152
CR549	152-0153-00			SEMICON D DEVICE:SILICON, 15V, 50MA	13715	FD7003
CR621	152-0141-02			SEMICON D DEVICE:SILICON, 30V, 150MA	07910	1N4152
CR622	152-0141-02			SEMICON D DEVICE:SILICON, 30V, 150MA	07910	1N4152
CR635	152-0141-02			SEMICON D DEVICE:SILICON, 30V, 150MA	07910	1N4152
CR641	152-0141-02			SEMICON D DEVICE:SILICON, 30V, 150MA	07910	1N4152
CR672	152-0141-02			SEMICON D DEVICE:SILICON, 30V, 150MA	07910	1N4152
CR674	152-0141-02			SEMICON D DEVICE:SILICON, 30V, 150MA	07910	1N4152
CR676	152-0141-02			SEMICON D DEVICE:SILICON, 30V, 150MA	07910	1N4152
CR806	152-0488-00			SEMICON D DEVICE:SILICON, 200V, 1500MA	80009	152-0488-00
CR808	152-0488-00			SEMICON D DEVICE:SILICON, 200V, 1500MA	80009	152-0488-00
CR811	152-0406-00			SEMICON D DEVICE:SILICON, 200V, 3A	83003	W01
CR820	152-0423-00			SEMICON D DEVICE:SILICON, 300V, 3A	04713	1N5000
CR821	152-0423-00			SEMICON D DEVICE:SILICON, 300V, 3A	04713	1N5000
CR852	152-0141-02			SEMICON D DEVICE:SILICON, 30V, 150MA	07910	1N4152
CR861	152-0141-02			SEMICON D DEVICE:SILICON, 30V, 150MA	07910	1N4152
CR867	152-0061-00			SEMICON D DEVICE:SILICON, 175V, 100MA	80009	152-0061-00
CR868	152-0061-00			SEMICON D DEVICE:SILICON, 175V, 100MA	80009	152-0061-00
CR875	152-0066-00			SEMICON D DEVICE:SILICON, 400V, 750MA	02735	37304
CR883	152-0141-02			SEMICON D DEVICE:SILICON, 30V, 150MA	07910	1N4152
CR885	152-0141-02			SEMICON D DEVICE:SILICON, 30V, 150MA	07910	1N4152
CR888	152-0141-02			SEMICON D DEVICE:SILICON, 30V, 150MA	07910	1N4152
CR891	152-0141-02			SEMICON D DEVICE:SILICON, 30V, 150MA	07910	1N4152
CR894	152-0141-02			SEMICON D DEVICE:SILICON, 30V, 150MA	07910	1N4152
CR895	152-0141-02	XB090000		SEMICON D DEVICE:SILICON, 30V, 150MA	07910	1N4152
CR896	152-0141-02			SEMICON D DEVICE:SILICON, 30V, 150MA	07910	1N4152
CR903	152-0066-00			SEMICON D DEVICE :SILICON, 400V, 750A	02735	37304
CR920	152-0141-02			SEMICON D DEVICE:SILICON, 30V, 150MA	07910	1N4152
CR924	152-0061-00			SEMICON D DEVICE:SILICON, 175V, 100MA	80009	152-0061-00
CR925	152-0061-00			SEMICON D DEVICE:SILICON, 175V, 100MA	80009	152-0061-00
CR935	152-0066-00			SEMICON D DEVICE:SILICON, 30V, 150MA	02735	37304
CR941	152-0141-02			SEMICON D DEVICE:SILICON, 30V, 150MA	07910	1N4152
CR950	152-0141-02			SEMICON D DEVICE:SILICON, 30V, 150MA	07910	1N4152
CR951	152-0141-02			SEMICON D DEVICE:SILICON, 30V, 150MA	07910	1N4152
CR952	152-0141-02			SEMICON D DEVICE:SILICON, 30V, 150MA	07910	1N4152
CR958	152-0066-00			SEMICON D DEVICE:SILICON, 400V, 750MA	02735	37304
CR961	152-0141-02			SEMICON D DEVICE:SILICON, 30V, 150MA	07910	1N4152
CR973	152-0061-00			SEMICON D DEVICE:SILICON, 175V, 100MA	80009	152-0061-00
CR980	152-0141-02			SEMICON D DEVICE:SILICON, 30V, 150MA	07910	1N4152
CR981	152-0141-02			SEMICON D DEVICE:SILICON, 30V, 150MA	07910	1N4152
CR989	152-0066-00			SEMICON D DEVICE:SILICON, 400V, 750MA	02735	37304
CR1021	152-0141-02			SEMICON D DEVICE:SILICON, 30V, 150MA	07910	1N4152
OR1023	152-0141-02			SEMICON D DEVICE:SILICON, 30V, 150MA	07910	1N4152
CR1024	152-0141-02			SEMICON D DEVICE:SILICON, 30V, 150MA	07910	1N4152
CR1026	152-0141-02			SEMICON D DEVICE:SILICON, 30V, 150MA	07910	1N4152
CR1131	152-0141-02			SEMICON D DEVICE:SILICON, 30V, 150MA	07910	1N4152
CR1133	152-0141-02			SEMICON D DEVICE:SILICON, 30V, 150MA	07910	1N4152
CR1190	152-0141-02			SEMICON D DEVICE:SILICON, 30V, 150MA	07910	1N4152
CR1202	152-0409-00			SEMICON D DEVICE:SILICON, 12,000V, 5MA	83003	VG-12X
CR1203	152-0409-00			SEMICON D DEVICE:SILICON, 12,000V, 5MA	83003	VG-1ZX
CR1211	152-0409-00			SEMICON D DEVICE:SILICON, 12,000V, 5MA	83003	G-12X
CR1219	152-0331-00			SEMICON D DEVICE:SILICON, 800V, 25MA	80009	152-0331-00

Ckt No. Number	Tektronix	Serial/Model No.		Name & Description	Mfr Code	Mfr Part
	Part No.	Eff	Dscont			
CR1223	152-0141-02			SEMICOND DEVICE:SILICON, 30V 150MA	07910	1N4152
CR1233	152-0242-00			SEMICOND DEVICE:SILICON, 225V 200MA	12969	NDP341
CR1234	152-0242-00			SEMICOND DEVICE:SILICON, 225V 200MA	12969	NDP341
CR1238	152-0242-00			SEMICOND DEVICE:SILICON, 225V 200MA	12969	NDP341
CR1239	152-0242-00			SEMICOND DEVICE:SILICON, 225V, 200MA	12969	NDP341
CR1251	152-0242-00			SEMICOND DEVICE:SILICON, 225V 200MA	12969	NDP341
CR1255	152-0242-00			SEMICOND DEVICE:SILICON, 225V 200MA	12969	NDP341
CR1257	152-0242-00			SEMICOND DEVICE:SILICON, 225V 200MA	12969	NDP341
CR1258	152-0242-00			SEMICOND DEVICE:SILICON, 225V, 200MA	12969	NDP341
CR1412	152-0008-00			SEMICOND DEVICE:GERANIUM, 75V 60MA	03877	T-12G
CR1413	152-0008-00			SEMICOND DEVICE:GERANIUM, 75V 60MA	03877	T-12G
CR1414	152-0008-00			SEMICOND DEVICE:GERANIUM, 75V 60MA	03877	T-12G
CR1424	152-0141-02			SEMICOND DEVICE:SILICON, 30V 150MA	07910	1N4152
CR1425	152-0141-02			SEMICOND DEVICE:SILICON, 30V, 150MA	07910	1N4152
CR1478	152-0141-02			SEMICOND DEVICE:SILICON, 30V 150MA	07910	1N4152
CR1496	152-0141-02			SEMICOND DEVICE:SILICON, 30V 150MA	07910	1N4152
CR1497	152-0141-02			SEMICOND DEVICE:SILICON, 30V 150MA	07910	1N4152
CR1498	152-0141-02			SEMICOND DEVICE:SILICON, 30V, 150MA	07910	1N4152
CR1499	152-0141-02			SEMICOND DEVICE:SILICON, 30V, 150MA	07910	1N4152
CR1500	152-0141-0			SEMICOND DEVICE:SILICON, 30V 150MA	07910	1N4152
CR1513	152-0141-02	XB130000		SEMICOND DEVICE:SILICON, 30V, 150MA	07910	1N4152
CR1515	152-0141-02	B130000		SEMICOND DEVICE:SILICON, 30V, 150MA	07910	1N4152
CR1538	152-0141-02			SEMICOND DEVICE:SILICON, 30V, 150MA	07910	1N4152
CR1579	152-0141-02			SEMICOND DEVICE:SILICON, 30V, 150MA	07910	N4152
CR1621	152-0141-02			SEMICOND DEVICE:SILICON, 30V 150MA	07910	1N4152
CR1663	152-014 1-02			SEMICOND DEVICE:SILICON, 30V, 150MA	07910	1N4152
CR1682	152-0141-02			SEMICOND DEVICE:SILICON, 30V 150MA	07910	1N4152
CR1710	152-0141-02			SEMICOND DEVICE:SILICON, 30V, 150MA	07910	1N4152
CR1727	152-0040-00			SEMICOND DEVICE:SILICON, 600V 1MA	14099	SC6
CR1733	152-0040-00			SEMICOND DEVICE:SILICON, 600V 1MA	14099	SC6
CR1737	152-0040-00			SEMICOND DEVICE:SILICON, 600V 1MA	14099	SC6
CR1738	152-0141-02			SEMICOND DEVICE:SILICON, 30V 150MA	07910	1N4152
CR1744	152-0040-00			SEMICOND DEVICE:SILICON,600V 1A	14099	SC6
CR1769	152-0141-02			SEMICOND DEVICE:SILICON, 30V 150MA	07910	1N4152
CR1771	152-0141-02			SEMICOND DEVICE:SILICON, 30V 150MA	07910	1N4152
CR1772	152-0141-02			SEMICOND DEVICE:SILICON, 30V 150MA	07910	1N4152
CR1797	152-0141-02			SEMICOND DEVICE:SILICON, 30V 150MA	07910	1N4152
CR1821	152-0141-02			SEMICOND DEVICE:SILICON, 30V 150MA	07910	1N4152
CR1822	152-0141-02			SEMICOND DEVICE:SILICON, 30V 150MA	07910	1N4152
CR1836	152-0141-02			SEMICOND DEVICE SILICON, 30V, 150MA	07910	1N4152
CR1855	152-0141-02			SEMICOND DEVICE:SILICON, 30V, 150MA	07910	1N4152
CR1856	152-0141-02			SEMICOND DEVICE:SILICON, 30V, 150MA	07910	1N4152
CR1874	152-0141-02			SEMICOND DEVICE:SILICON, 30V, 150MA	07910	1N4152
CR1875	152-0141-02			SEMICOND DEVICE:SILICON, 30V, 150MA	07910	1N4152
CR1896	152-0141-02			SEMICOND DEVICE:SILICON, 30V 150MA	07910	1N4152
CR1898	152-0141-02			SEMICOND DEVICE:SILICON, 30V, 150MA	07910	1N4152
CR1912	152-0061-00			SEMICOND DEVICE:SILICON, 175V 100MA	80009	152-0061-00
CR1921	152-0141-02			SEMICOND DEVICE:SILICON, 30V, 150MA	07910	1N4152
CR1924	152-0141-02			SEMICOND DEVICE:SILICON, 30V 150MA	07910	1N4152
CR1926	152-0141-02			SEMICOND DEVICE:SILICON, 30V, 150MA	07910	1N4152
CR2124	152-0141-02			SEMICOND DEVICE:SILICON, 30V 150MA	07910	1N4152
CR2125	152-0141-02			SEMICOND DEVICE:SILICON, 30V, 150MA	07910	1N4152
CR2127	152-0141-02			SEMICOND DEVICE:SILICON, 30V, 150MA	07910	1N4152
CR2140	152-0141-02			SEMICOND DEVICE:SILICON, 30V, 150MA	07910	1N4152
CR2141	152-0141-02			SEMICOND DEVICE:SILICON, 30V 150MA	07910	1N4152

Ckt No. Number	Tektronix		Serial/Model No.		Name & Description	Mfr Code	Mfr Part
	Part No.	Eff	Dscont				
CR2142	152-0141-02				SEMICOND DEVICE SILICON, 30V, 150MA	07910	1N4152
CR2145	152-0141-02				SEMICOND DEVICE:SILICON, 30V, 150MA	07910	1N4152
CR2146	152-0141-02				SEMICOND DEVICE:SILICON, 30V, 150MA	07910	1N4152
CR2156	152-0141-02				SEMICOND DEVICE: SILICON, 30V, 150MA	07910	1N4152
CR2157	152-0141-02				SEMICOND DEVICE: SILICON, 30V, 150MA	07910	1N4152
CR2162	152-0141-02				SEMICOND DEVICE: SILICON, 30V, 150MA	07910	1N4152
CR2163	152-0141-02				SEMICOND DEVICE: SILICON, 30V, 150MA	07910	1N4152
CR2166	152-0141-02				SEMICOND DEVICE: SILICON, 30V, 150MA	07910	1N4152
CR2167	152-0141-02				SEMICOND DEVICE: SILICON, 30V, 150MA	07910	1N4152
CR2170	152-0141-02				SEMICOND DEVICE: SILICON, 30V, 150MA	07910	1N4152
CR2171	152-0141-02				SEMICOND DEVICE. SILICON, 30V, 150MA	07910	1N4152
CR2174	152-0141-02				SEMICOND DEVICE: SILICON, 30V, 150MA	07910	1N4152
CR2175	152-0141-02				SEMICOND DEVICE: SILICON, 30V, 150MA	07910	1N4152
CR2292	152-0141-02				SEMICOND DEVICE: SILICON, 30V, 15MA	07910	1N4152
CR2193	152-0141-02				SEMICOND DEVICE: SILICON, 30V, 150MA	07910	1N4152
CR2196	152-0141-02				SEMICOND DEVICE -SILICON, 30V, 150MA	07910	1N4152
CR2198	152-0141-02				SEMICOND DEVICE: SILICON, 30V, 150MA	07910	1N4152
CR2226	152-0141-02				SEMICOND DEVICE: SILICON, 30V, 150MA	07910	1N4152
CR2235							
CR2266	152-0333-00	XB120000			SEMICOND DEVICE SILICON, 55V, 200A	80009	152-0333-00
CR2331	152-0141-02				SEMICOND DEVICE:SILICON, 30V, 150MA	07910	LN4152
CR2414	152-0612-00				SEMICOND DEVICE:V VAR CAP., 4V, 17.5PF	80009	152-0612-00
CR2456	152-0612-00				SEMICOND DEVICE:V VAR CAP., 4V, 17.5PF	80009	152-0612-00
CR2514	152-0612-00				SEMICOND DEVICE:V VAR CAP., 4V, 17.SPF	80009	152-0612-00
CR2556	152-0612-00				SEMICOND DEVICE:V VAR CAP., 4V, 17.5PF	80009	152-0612-00
DL2400	119-0363-00				DELAY LINE, ELEC:	80009	119-0368-00
DS1001	150-0121-02				LAMP, CARTRDGE: GREEN, 5V, 60MA	80009	150-0121-02
DS1090	150-0029-00				LAMP, INCAND:6.3V, 0.20A	08806	349
DS1091	150-0029-00				LAMP, INCAND:6.3 V, .20A	08806	349
DS1092	150-0029-00				LAMP, INCAND:6.3V, 0.20A	08806	349
F814	159-0021-00				FUSE, CARTRIDGE 3AG, 2A, 25V, FAST-BLOW	71400	AGC 2
F855	159-0083-00				FUSE, CARTRIDGE:0.15A, 250V, FAST-BLOW	71400	AGC 15/100
F1000	159-0026-00				FUSE, CARTRIDGE:3AG, 3.2A, 125V, SL4DW-BLOW	71400	MDX 3 2/10
J1	131-0767-08				CONNECTOR, RCPT, :PLUG-IN CKT BD, 70 CONTACT	80009	131-0767-08
J2	131-0767-08				CONNECTOR, RCPT, :PLUG-IN CKT BD, 70 CONTACT	80009	131-0767-08
J3	131-0767-07				CONNECTOR, RCPT, :PLUG-IN CKT BD, 70 CONTACT	80009	131-0767-07
J26	131-1003-00				CONNECTOR BODY, :CKT BD -MT, 3 PRONG	80009	131-1003-00
J27	131-1003-00				CONNECTOR BOKY, :CKT BD MT, 3 PRONG	80009	131-1003-00
J503	131-1003-00				CONNECTOR BODY, :CKT BD MT, 3 PRONG	80009	131-1003-00
J508	131-1003-00				CONNECTOR BODY, :CKT BD MT, 3 PRONG	80009	131-1003-00
J601	131-1003-00				CONNECTOR BODY, :CKT BD MT, 3 PRONG	80009	131-1003-00
J603	131-1003-00				CONNECTOR BODY, :CKT BD MT, 3 PRONG	80009	131-1003-00
J629	131-0955-00				CONNECTOR,RCPT, : BNC FEMALE	24931	28JR200-1
J649	131-0955-00				CONNECTOR, RCPT, :BNC, FEMALE	24931	28JR200-1
J679	131-0955-00				CONNECTOR, RCPT, :BNC, FEMALE	24931	28JR200-1
J1047	131-0955-00				CONNECTOR, RCPT, :BNC, FEMALE	24931	28JR200-1
J1050	131-0955-00				CONNECTOR, RCPT: BNC, FEMALE	24931	28JR200-1
J1103	131-1003-00				CONNECTOR BODY, :CKT RD MT, 3 PRONG	80009	131-1003-00
I1134	131-1003-00				CONNECTOR BODY, :CKT BD MT, 3 PRONG	80009	131-1003-00
J1135	131-1003-00				CONNECTOR BODY, :CKT BD MT, 3 PRONG	80009	131-1003-00
J2132	131-1003-00				CONNECTOR BODY, :CKT BD MT, 3 PRONG	80009	131-1003-00
J2138	131-1003-00				CONNECTOR BODY, :CKT BD MT, 3 PRONG	80009	131-1003-00
J21391331	131-1003-00				CONNECTOR BODY, :CKT BD MT, 3 PRONG	80009	131-1003-00

Ckt No. Number	Tektronix		Serial/Model No.		Name & Description	Mfr Code	Mfr Part
	Part No.	Eff	Dscont				
J2192	131-1003-00				CONNECTOR BODY, CKT BD MT, 3 PRONG	80009	131-1003-00
J2296	131-1003-00				CONNECTOR BODY, CKT BD MT, 3 PRONG	80009	131-1003-00
J2299	131-1003-00				CONNECTOR BODY, CKT BD MT, 3 PRONG	80009	131-1003-00
J2401	131-1003-00				CONNECTOR BODY, CKT BD W T, 3 PRONG	80009	131-1003-00
J2501	131-1003-00				CONNECTOR BODY, :CKT BD MT, 3 PRONG	80009	131-1003-00
J2534	131-1003-00				CONNECTOR BODY, :CKT BD MT, 3 PRONG	80009	131-1003-00
L1198	108-0646-00				COIL, RF:80UH	80009	108-0646-00
L1284	108-0605-00				COIL, TUBE DEFLE:Y AXIS ALIGNMENT	80009	108-0605-00
L1295	108-0721-00				COIL, TUBE DEFL:TRACE ROTATOR	80009	108-0721-00
L1929 ¹							
L1985	108-0538-00				COIL, RF:2.7UH	76493	70F276A
L2283	108-0331-00				COIL, RF:0.75UH	80009	108-0331-00
L2386	108-0606-00				COIL, RF:50NH	80009	108-0606-00
L2396	108-0606-00				COIL, RF:50NH	80009	108-0606-00
L2441	276-0528-00				SHIELDING BEAD, :0.1UH	80009	276-0528-00
L2448	108-0579-00				TRANSFORMER, RF:120NH	80009	108-0579-00
L2519	108-0707-00				COIL, .RF:150N	80009	108-0707-00
L2541	276-0528-00				SHIELDING BEAD, :0.1UH	80009	276-0528-00
L2548	108-0579-00				TRANSFORMER, RF:120NH	80009	108-0579-00
L2595	108-0538-00				COIL, RF:2.7UH	76493	70F276A1
LR55	1085-245-00				COIL, RF:3.9UH	80009	108-0245-00
LR193	108-0245-00				COIL, RF:3.9UH	80009	108-0245-00
LR195	108-0245-00				COIL, RF:3.9UH	80009	108-0245-00
LR198	108-0245-00				COIL, RF:3.9UH	80009	108-0245-00
LR2472	08-0777-00				COIL, RF:10NH	80009	108-0777-00
LR2572	108-0777-00				COIL, RF.10NH	80009	108-0777-00
Q90A,B	151-0232-00				TRANSISTOR: SILICON, NPN, DUAL	12040	NS7348
Q108	151-0199-00				TRANSISTOR: SILICON, PNP	04713	MPS3640
Q132	151-0199-00				TRANSISTOR:SILICON, PNP	04713	MPS3640
Q137	151-0223-00				TRANSISTOR: SILICON, NPN	80009	151-0223-00
Q142	151-0199-00				TRANSISTOR: SILICON, PNP	04713	MPS3640
Q147	151-0223-00				TRANSISTOR: SILICON, NPN	80009	151-0223-00
Q150	151-0213-00				TRANSISTOR: SILICON, NPN	80009	151-0223-00
Q162	151-0199400				TRANSISTOR:SILICON, PNP	04713	MPS3640
Q167	151-0223-00				TRANSISTOR:SILICON, NPN	80009	151-0223-00
Q314	151-0190-00				TRANSISTOR: SILICON, NPN	80009	151-019P-00
Q334	151-0190-00				TRANSISTOR:SILICON, NPN	80009	151-0190-00
Q336	151-0190-00				TRANSISTOR:SILICON, NPN	80009	151-0109-00
Q344	151-0221-00				TRANSISTOR:SILICON , NPN	80009	151-0221-00
Q346	151-0221-00				TRANSISTOR: SILICON, PNP	80009	151-0221-00
Q539	151-0301-00				TRANSISTOR.SILICON, PNP	04713	2N2907A
Q547	151-0301-00				TRANSISTOR:SILICON, PNP	04713	2N2907A
Q551	151-0103-00				TRANSISTOR:SILICON, NPN	04713	2N2219A
Q553	151-0103-00				TRANSISTOR:SILICON, NPN	04713	2N2219A
Q558	151-0406-00				TRANSISTOR:SILICON, PNP	07263	S37880
Q560	151-0347-00				TRANSISTOR:SILICON, NPN	80009	151-0347-00
Q578	151-0406-00				TRANSISTOR:SILICON, PNP	07263	S37880
Q580	151-0347-00				TRANSISTOR:SILICON, NPN	80009	151-0347-00
Q606	151-0221-00				TRANSISTOR SILICON, PNP	80009	151-0221-00
Q618	151-0221-00				TRANSISTOR:SILICON, PNP	80009	151-0221-00
Q620	151-0220-00	B010100	B119999		TRANSISTOR:SILICON, PNP	80009	151-0220-00
Q620	151-0221-00	B120000			TRANSISTOR:SILICON, PNP	80009	151-0221-00

¹Furnished with CRT Socket Cable.

Ckt No. Number	Tektronix		Serial/Model No.		Name & Description	Mfr Code	Mfr Part
	Part No.	Eff	Dscont				
Q631	151-0190-00				TRANSISTOR:SILICON, NPN	80009	151-0190-00
Q634	151-0190-00				TRANSISTOR:SILICON, NPN	80009	151-0190-00
Q640	151-0220-00				TRANSISTOR:SI LICON, PNP	80009	151-0220-00
Q662	151-0190-00				TRANSISTOR:SILICON, NPN	80009	151-0190-00
Q666	151-0190-00				TRANSISTOR SILICON, NPN	80009	151-0190-03
Q672	151-0188-00				TRANSISTOR:SILICON, PNP	04713	N3906
Q82	151-0223-00				TRANSISTOR.SILICON, NPN	80009	151-0223-00
Q829	151-0223-00				TRANSISTOR:SILICON, NPN	80009	151-0223-00
Q835	151-0334-00				TRANSISTOR.SILICON, NPN	80009	151-0334-00
Q850	151-0337-00				TRANSISTOR:SILICON, NPN	21845	93SX287
Q852	151-0276-00				TRANSISTOR:SILICON, PNP	04713	2N5087
Q860	151-0347-00				TRANSISTOR.SILICON, NPN	80009	151-0347-00
Q863	151-0347-00				TRANSISTOR:SILICON, NPN	80009	151-0347-00
Q869	151-0347-00				TRANSISTOR:SILICON, NPN	80009	151-0347-00
Q872	151-0279-00	8010100	8142121		TRANSISTOR:SILICON, NPN	07263	S25381
Q872	151-0407-00		142122		TRANSISTOR:SILICON, NPN	80009	151-0407-00
Q874	151-0336-00	B010100	B070879		TRANSISTOR:SILICON, NPN	21845	93SX288
Q874	151-0487-00		B070880		TRANSISTOR:SILION, NPN	80009	151-0487-00
Q876A,B	151-0232-00				TRANSISTOR.SILIDON, NPN, DUAL	12040	NS7348
Q886A,B	151-0232-00				TRANSISTOR.SILICON, NPN, DUAL	12040	NS7348
Q896	151-0228-00				TRANSISTOR:SILICON, PNP, SEL FROM 2N4888	07263	S21862
Q900	151-0347-00				TRANSISTR:SILICON, NPN	80009	151-0347-00
Q903	151-0336-00	8010100	B070879		TRANSISTOR:SILICON, NPN	21845	93SX288
Q903	151-0487-00		B070880		TRANSISTOR:SILICON, NPN	80009	151-0487-00
Q908	151-0292-00				TRANSISTOR:SILICON, NPN	01295	TIS100
Q909	151-0292-00				TRANSISTOR:SILICON, NPN	01295	TIS100
Q910	151-0292-00				TRANSISTOR:SILICON, NPN	01295	TIS100
Q919A, B	151-0232-00				TRANSISTOR:SILICON, NPN, DUAL	12040	NS7348
Q926	151-0347-00				TRANSISTOR:SILICON, NPN	80009	151-0347-00
Q931	151-0260-02				TRANSISTOR:SILICON, NPN	04713	2N5859
Q933	151-0337-00	B010100	B070879		TRANSISTOR SILICON, NPN	21845	93SX287
Q933	151-0487-00		B070880		TRANSISTOR:SILICON, NPN	80009	151-0487-00
Q936A, B	151-0232-00				TRANSISTOR:SILION, NPN, DUAL	12040	NS7348
Q943A, B	151-0232-00				TRANSISTOR:SILICON, NPN, D UAL	12040	Ni7348
Q952	151-0134-00				TRANSISTOR:SILICON, PNP	04713	2N2905A
Q956	151-0260-02				TRANSISTOR:SILICON, NPN	04713	2N5859
Q958	151-0337-00	B010100	B070879		TRANSISTOR:SILICON, NPN	21845	93SX287
Q958	151-0487-00		B070880		TRANSISTOR:SILICON, NPN	80009	151-0487-00
Q964A, B	151-0232-00				TRANSISTR:SILICON NPN, DUAL	12040	NS7348
Q985	151-0136-00				TRANSISTOR:SILICON, NPN	02735	35495
Q988	151-0337-00				TRANSISTOR:SILICON, NPN	21845	93SX287
Q1105	151-0190-00				TRANSISTOR.SILICON, NPN	80009	151-0190-00
Q1111	151-0192-00				TRANSISTOR:SILICON, NPN, SEL FROM MPS6521	80009	151-0192-00
Q1113	151-0347-00				TRANSISTOR:SILICON, NPN	80009	151-0347-00
Q1122	151-0406-00				TRANSISTOR:SILICON, PNP	07263	537880
Q1127	151-0188-00				TRANSISTOR:SILICON, PNP	04713	2N3906
Q1136	151-0190-00				TRANSISTOR:SILICON, NPN	80009	151-0190-00
Q1145	151-0190-00				TRANSISTOR:SILICON, NPN	80009	151-0190-00
Q1150	151-0188-00				TRANSISTOR:SILICON, PNP	04713	2N3906
Q1155	151-0188-00				TRANSISTOR:SILICON, PNP	04713	2N3906
Q1164	151-0406-00				TRANSISTOR:SILICON, PNP	07263	S37880
Q1167	151-0347-00				TRANSISTOR:SILICON, NPN	80009	151-0347-00
Q1184	151-0126-00				TRANSISTOR:SILICON, NPN	07263	2N2484
Q1187	151-0188-00				TRANSISTOR.SILICON, PNP	04713	2N3906

Ckt No. Number	Tektronix		Serial/Model No.		Name & Description	Mfr Code	Mfr Part
	Part No.	Eff	Dscont				
Q1190	151-0136-00				TRANSISTOR:SILICON, NPN	02735	35495
Q1195	151-0140-00				TRANSISTOR:SILICON, NPN	80009	151-0140-00
Q1416	151-0223-00				TRANSISTOR:SILICON, NPN	80009	151-0223-00
Q1426	151-0342-00				TRANSISTOR:SILICON, PNP	80009	151-0342-00
Q1428	151-0342-00				TRANSISTOR:SILICON, PNP	80009	151-0342-00
Q1440	151-0190-00				TRANSISTOR:SILICON, NPN	80009	151-0190-00
Q1446	151-0190-00				TRANSISTOR:SILICON, NPN	80009	151-0190-00
Q1450	151-0410-00				TRANSISTOR: SILICON, PNP	80009	151-0410-00
Q1453	151-0410-00				TRANSISTOR:SILICON, PNP	80009	151-0410-00
Q1475	151-0410-00				TRANSISTOR:SILICON, PNP	80009	151-0410-00
Q1478	151-0192-00				TRANSISTOR:SILICON, NPN, SEL FROM MPS6521	80009	151-0192-00
Q1481	151-0410-00				TRANSISTOR:SILICON, PNP	80009	151-0410-00
Q1485	151-0410-00				TRANSISTOR:SILICON, PNP	80009	151-0410-00
Q1493	151-0192-00				TRANSISTOR:SILICON, NPN, SEL FROM MPS6521	80009	151-0192-00
Q1513	151-0410-00				TRANSISTOR: SILICON, PNP	80009	151-0410-00
Q1518	151-0508-00				TRANSISTOR: SILICON, NPN, PROGRAMMABLE	03508	2N6027
Q1524	151-0342-00				TRANSISTOR:SILICON, PNP	80009	151-0342-00
Q1539	151-0341-00				TRANSISTOR:SILICON, NPN	07263	5040065
Q1541	151-0341-00				TRANSISTOR:SILICON, NPN	07263	S040065
Q1553	151-0341-00				TRANSISTOR:SILICON, NPN	07263	S040065
Q1564	151-0341-00				TRANSISTOR:SILICON, NPN	07263	S040065
Q1569	151-0341-00				TRANSISTOR:SILICON, NPN	07263	040065
Q1576	151-0341-00				TRANSISTOR:SILICON, NPN	07263	S040065
Q1585	151-0341-00				TRANSISTOR:SILICON, NPN	07263	S040065
Q1587	151-0341-00				TRANSISTOR:SILICON, NPN	07263	S040065
Q1595	151-0341-00				TRANSISTOR:SILICON, NPN	07263	S040065
Q1613	151-0341-00	B010100	B129999X		TRANSISTOR:SILICON, NPN	07263	S040065
Q1621	151-0508-00				TRANSISTOR:SILICON, NPN, PROGRAMMABLE	03508	2N6027
Q1625	151-0341-00				TRANSISTOR:SILICON, NPN	07263	S040065
Q1631	151-0508-00				TRANSISTOR:SILICON, NPN, PROGRAMMABLE	03508	2N6027
Q1644	151-0341-00				TRANSISTOR:SILICON, NPN	07263	5040065
Q1652	151-0341-00				TRANSISTOR:SILICON, NPN	07263	S040065
Q1661	151-0342-00				TRANSISTOR:SILICON, PNP	80009	151-0342-00
Q1667	151-0342-00				TRANSISTOR:SILICON, PNP	80009	151-0342-00
Q1673	151-0342-00				TRANSISTOR:SILICON, PNP	80009	151-0342-00
Q1686	151-0342-00				TRANSISTOR:SILICON, PNP	80009	151-0342-00
Q1692	151-0342-00				TRANSISTOR:SILICON, PNP	80009	151-0342-00
Q1697	151-0342-00				TRANSISTOR:SILICON, PNP	80009	151-0342-00
Q1701	151-0410-00				TRANSISTOR:SILICON, PNP	80009	151-0410-00
Q1704	151-0410-00				TRANSISTOR:SILICON, PNP	80009	151-0410-00
Q1708	151-0347-00	B010100	B159999		TRANSISTOR:SILICON, NPN	80009	151-0347-00
Q1708	151-0624-00	B160000			TRANSISTOR:SILICON, NPN	01295	SKA3418
Q1711	151-0347-00	B010100	B159999		TRANSISTOR:SILICON, NPN	80009	151-0347-00
Q1711	151-0624-00	B160000			TRANSISTOR:SILICON, NPN	01295	SKA3418
Q1718	151-0188-00	B010100	B159999		TRANSISTOR:SILICON, PNP	01295	2N3906
Q1718	151-0301-00	B160000			TRANSISTOR:SILICON, PNP	04713	ZN2907A
Q1723	151-0347-00	B010100	B159999		TRANSISTOR:SILICON, NPN	80009	151-0347-00
Q1723	151-0624-00	B160000			TRANSISTOR:SILICON, NPN	01295	SKA3418
Q1728	151-0444-00	B010100	B159999		TRANSISTOR:SILICON, NPN	80009	151-0444-00
Q1728	151-0301-00	B160000			TRANSISTOR:SILICON, PNP	04713	ZN2907A
Q1734	151-0444-00				TRANSISTOR:SILICON, NPN	80009	151-0444-00
Q1739	151-0444-00				TRANSISTOR:SILICON, NPN	80009	151-0444-00
Q1743	151-0444-00				TRANSISTOR:SILICON, NPN	80009	151-0444-00
Q1761	151-0341-00				TRANSISTOR:SILICON, NPN	07263	S040065
Q1775	151-0342-00				TRANSISTOR:SILICON, PNP	80009	151-0342-00
Q1788	151-0410-00				TRANSISTOR:SILICON, PNP	80009	151-0410-00
Q1790	151-0410-00				TRANSISTOR:SILICON, PNP	80009	151-0410-00
Q1795	151-0347-00				TRANSISTOR:SILICON, NPN	80009	151-0347-00

Ckt No. Number	Tektronix		Serial/Model No.		Name & Description	Mfr Code	Mfr Part
	Part No.	Eff	Dscont				
Q1798	151-0347-00				TRANSISTOR:SILICON, NPN	80009	151-0347-00
Q1805	151-0341-00				TRANSISTOR:SILICON, NPN	07263	2N3565
Q1810	151-0341-00				TRANSISTOR:SILICON, NPN	07263	2N3565
Q1825	151-0410-00				TRANSISTOR: SILICON, PNP	04713	SP6765
Q1828	151-0347-00	8010100	8159999		TRANSISTOR:SILICON, NPN	80009	151-0347-00
Q1828	151-0624-00	8160000			TRANSISTOR: SILICON, NPN	01095	S41
Q1835	151-0347-00				TRANSISTOR:SILICON, NPN	80009	151-0347-00
Q1844	151-0341-00				TRANSISTOR:SILICON, NPN	07263	2N3565
Q1847	151-0341-00				TRANSISTOR:SILICON, NPN	07263	2N3565
Q1859	151-0410-00				TRANSISTOR:SILICON, PNP	04713	sPs6765
Q186Z	151-0347-00				TRANSISTOR:SILICON, NPN	80009	151-0347-00
Q1880	151-0410-00				TRANSISTOR:SILICON, PNP	04713	SPS6765
Q1883	151-0347-00				TRANSISTOR:SILICON, NPN	80009	151-0347-00
Q1903	151-0410-00				TRANSISTOR:SILICON, PNP	04713	SPS6765
Q1906	151-0347-00				TRANSISTOR:SILICON, NPN	80009	151-0347-00
Q1925	151-0410-00				TRANSISTOR:SILICON, PNP	04713	SP6765
Q1928	151-0347-00				TRANSISTOR:SILICON, NPN	80009	151-0347-00
Q2108	151-0223-00				TRANSISTOR:SILICON, NPN	80009	151-0223-00
Q2112	151-0221-00				TRANSISTOR:SILICON, NPN	80009	151-0221-00
Q2138	151-0188-00				TRANSISTOR:SILICON, PNP	04713	2N3906
Q2153	151-0192-00				TRANSISTOR:SILICON, NPN, SEL FROM MPS6521	80009	151-0192-00
Q2159	151-0190-00				TRANSISTOR:SILICON, NPN	80009	151-0190-00
Q2215A, B	151-0232-00				TRANSISTOR:SILICON, NPN, DUAL	12040	NS7348
Q2223	151-0190-00				TRANSISTOR: SILICON, NPN	80009	151-0190-00
Q2225	151-0188-00				TRANSISTOR :SILICON, PNP	04713	2N3906
Q2229	151-0190-00				TRANSISTOR: SILICON, NPN	80009	151-0190-00
Q2240	151-0190-00				TRANSISTOR: SILICON, NPN	80009	151-0190-00
Q2286	151-0188-00				TRANSISTOR: SILICON, PNP	04713	2N3906
Q2287	151-0188-00				TRANSISTOR: SILICON, PNP	04713	2N3906
Q2296	151-0188-00				TRANSISTOR: SILICON, PNP	04713	2N3906
Q2299	151-0188-00				TRANSISTOR: SILICON, PNP	04713	2N3906
Q2365A,B	151-0232-00				TRANSISTOR: SILICON, NPN, DUAL	12040	NS7348
Q2386	151-0447-00				TRANSISTOR: SILICON, NPN	80009	151-0447-00
Q2390	151-0190-00				TRANSISTOR: SILICON, NPN	80009	151-0190-00
Q2396	151-0447-00				TRANSISTOR: SILICON, NPN	80009	151-0447-00
Q2405	151-0447-00				TRANSISTOR: SILICON, NPN	80009	151-0447-00
Q2423	151-0302-00				TRANSISTOR: SILICON, NPN	04713	2N2222A
Q2427	151-0302-00				TRANSISTOR: SILICON, NPN	04713	2N2222A
Q2430	151-0192-00				TRANSISTOR:SILICON, NPN, SEL FROM MPS6521	80009	151-0192-00
Q2441	151-0271-00				TRANSISTOR:SILICON, PNP	01295	sKA4504
Q2455	151-0448-00				TRANSISTOR:SILICON, NPN	80009	151-0448-00
Q2468	151-0451-00				TRANSISTOR:SILICOK, NPN	80009	151-0451-00
Q2505	151-0447-00				TRANSISTOR:SILICON, NPN	80009	151-0447-00
Q2530	151-0192-00				TRANSISTOR:SILICON, NPN, SEL FROM MPS6521	80009	151-0192-00
Q2541	151-0271-00				TRANSISTOR:SILICON, PNP	01295	SKA4504
Q2552	151-0301-00				TRANSISTOR:SILICON, PNP	04713	Z2N2907A
Q2555	151-0440-00				TRANSISTOR:SILICON, NPN	80009	151-0448-00
Q2568	151-0451-00				TRANSISTOR:SILICON, NPN	80009	151-0451-00
R12	321-0260-00				RES., FXD, FILM:4.99K OHM, 1%, 0.125W	75042	O CEAT-499LF
R14	321-0260-00				RES., FXD, FILM:4.99K OHM, 1%, 0.125w	75042	CEATO-4991F
R20	315-0103-00				RES., FXD, CMPSN:10K OHM, 5%, 0.25W	01121	C81035
R21	315-0103-00				RES., FXD, CMPSN:10K OHM, 5%, 0.25W	01121	CB1035
R26	315-0122-00				RES., FXD, CMPSN:1.2K OHM, 5%, 0.25W	01121	CB1225

Ckt No. Number	Tektronix	Serial/Model No.		Name & Description	Mfr Code	Mfr Part
	Part No.	Eff	Dscont			
R28	315-0510-00			RES., FXD, CMPSN:51 OHM, 5%, 0.25W	01121	CB5105
R29	315-0510-00			RES., FXD, CMPSN:51 OHM, 5%, 0.25W	01121	CB5105
R31	315-0122-00			RES., FXD, CMPSN:1.2K OH, 5%, 0.25W	01121	CB1225
R33	315-0682-00			RES., FXD, CMPSN:6.8K OHM, %, 0.25W	01121	CB6825
R34	315-0122-00			RES., FXD, CMPSN:1.2K OHM, 5%, 0.25W	01121	CB1225
R35	315-0122-00			RES., FXD, CMPSN:1.2K OHM, 5%, 0.25W	01121	CB1225
R36	321-0231-00			RES., FXD, FILM:2.49K OHM, 1%, 0.125W	75042	CEATO-2491F
R37	315-0152-00			RES., FXD, CMPSN:1.5K OHM, 5%, 0.25W	01121	CB1525
R38	315-0152-00			RES., FXD, CMPSN:1.5K OHM, 5%, 0.25W	01121	CB1525
R39	315-0152-00			RES., FXD, CMPSN:1.5K OHM, 5%, 0.25W	01121	CB1525
R42	315-0105-00			RES., FXD, CMPSN:1M OHM, 5%, 0.25W	01121	CB10055
R44	315-0152-00			RES., FXD, CMPSN:1.5K OHM, 5%, 0.25W	01121	CB1525
R47	315-0243-00			RES., FXD, CMPSN:24K OHM, %, 0.25W	01121	CB2435
R48	315-0152-00			RES., FXD, CMPSN:1.5K OHM, 5%, 0.25W	01121	CB1525
R49	315-0104-00			RES., FW, CMPSN:100K OHM, 5, 0.25W	01121	CB1045
R50	315-0223-00			RES., FXD, CMPSN:22K OHM, 5%, 0.25W	01121	CB2235
R51	321-0193-00			RES.FXD, FILM:1K OHM, %, 0.125W	75042	CEATa-1001F
R53	315-0223-00			RES.FXD, CMPSN:22K OHM, 5%, 0.25W	01121	CB2235
R54	321-0193-00			RES, FXD, FILM:1K OHM, 1%, 0.125W	75042	CEATO-1001F
R56	321-0169-00			RES., FXD, FILM:562 OHM, 1%, 0.125W	75042	CEATO-5 620F
R57	321-0266-00			RES., FXD, FILM:5.76K OHM, %1, 0.125W	75042	CEATO-5761F
R58	315-0101-00			RES., FXD, CMPSN:100 OHM, 5%, 0.25W	01121	CB1015
R59	321-0282-00			RES., FXD, FILM:8.45K OHM, 1%, 0.125W	75042	CEA- 8451F
R61	315-0512-00			RES., FXD, CMPSN:5.1K OHM, 5t, 0.25W	01 121	CB5125
R62	315-0103-00			RES., FXD, CMPSN:10KOHM, 5, 0.25W	01121	CB1035
R63	315-0102-00			RES., FXD, CMPSN:1K OHM, 5%, 0.25W	01121	CB102ZS
R67	315-0512-00			RES., FXD, CMPSN:5.1K OHM, 5%, 0.25W	01121	CB5125
R74	315-0510-00			RES., FXD, CMPSN:51 OHM, 5%, 0.25W	01121	CB5105
R76	315-0222-00			RES., FXD, CMPSN:2.2K OHM, 5%, 0.25W	01121	CB2225
R77	315-0362-00			RES., FXD, CMPSN:3.6K OHM, 5%, 0.25W	01121	CB3625
R78	315-0392-00			RES., FXD, CMPSN:3.9K OHM, 5%, 0.25W	01121	CB3925
R80	321-0258-00			RES., FXD , FILM:4.75K OHM, 1%, 0.125W	75042	CEATO-4751F
R82	315-0510-00			RES., FXD, CMPSN:51 OHM, 5%, 0.25W	01121	CB5105O
R83	315-0510-00			RES., FXD, CMPSN:51 OHM, 5%, 0.25W	01121	CB5105
R84	315-0510-00			RES., FXD, CMPSN:51 OHM, 5%, 0.25W	01121	CB5105
R85	315-0471-00			RES., FXD, CMPSN:470 OHM, 5%, 0.25W	01121	CB4715
R86	315-0100-0			RES., FXD, CMPSN:10 OHM, 5%, 0.25W	01121	CB1005
R88	321-0230-00			RES., FXD, FILM:2.43K OHM, 1%, 0.125W	75042	CEATO-2431F
R89	3s15-0910-00			RES, FXD, CMPSN:91 OHM, 0.25W	01121	CB9105
R90	315-0362-00			RES., FXD, CMPSN:3.6K OHM, 5%, 0.25W	01121	C3625
R92	321-0202-00			RES, FXD, FILM:1.24K OHM, 1%, 0.125W	75042	CEATO-124 1F
R93	315-0102-00			RES., FXD, CMPSN:1K OHM, 5%, 0.25W	0112o	CB1025
R95	315-0152-00			RES., FXD, CMPSN:1.5K OHM, 5%, 0.25W	011i21	CB1525
R96	315-0511-00			RES., FXD , CMPSN:510 OHM, 5%, 0.25W	01121	CB5115
R98	315-0511-00			RES., FXD, CMPSN:510 OHM, 5%, 0.25W	01121	CB5115
R99	315-0221-00			RES, FXD, CM9SN:220 OHM, 5%, 0.25W	01121	CB2215
R101	315-0302-00			RES., FXD, CMPSN:3K OHM, 5%, 0.25W	01121	CB3025
R104	315-0103-00			RES., FXD, CMPSN:10K OHM, %, 0.25W	01e21	CB1035
R105	315-0472-00			RES., FXD, CMPSN:4.7K OHM, 5%, 0.25W	01121	CB4725
R106	315-0273-00			RES., FXD, CMPSN:27K OHM, 5%, 0.25W	01121	CB2735
R109	321-0243-00			RES., FXD , FILM:3.32K OHM , 1%, 0.125W	75042	CEATO-3321F
Ro10	321-0097-00			RES, FXD, FILM:100 OHM, 1%, 0.125W	75042	CEATO-1000F
R112	321-0097-00			RES.FXD, FILM:100 OHM,1%, 0.125W	75042	CEATO-1000F

Ckt No.	Tektronix	Serial/Model No.		Name & Description	Mfr Code	Mfr Part
	Part No.	Eff	Dscont			
R123	315-0102-00			RES., FXD, CMPSN:1K OHM, 5%, 0.25W	01121	CB1025
R24	315-0511-00			RES., FXD, CMPSN:510 OHM, 5%, 0.25W	01121	CB5115
25	315-0102-00			RES., FXD, CMPSN:1K OHM, 5%, 0.25W	01121	CB1025
R126	315-0102-00			RES., FXD, CMPSN:1K OHM, 5%, 0.25W	01121	CB1025
R130	315-0102-00			RES., FXD, CMPSN:1K OHM, 5%, 0.25W	01121	CB1025
S132	315-0222-00			RES., FXD, CMPSN:2.2K OM, 5%, 0.25W	01121	CB2225
R133	315-0102-00			RES., FXD, CMPSN:1K OHM, 5%, 0.25W	01121	CB1025
R134	315-0821-00			RES., FXD, CMPSN:820 OHM, 5%, 0.25W	01121	CB8215
R135	315-0123-00			RES., FXD, CMPSN:12K OHM, 5%, 0.25W	01121	CB1235
R136	315-0681-00			RES., FXD, CMPSN:680 OHM, 5%, 0.25W	01121	CB6815
R137	315-0221-00			RES., FXD, CMPSN:220 OHM, 5%, 0.25W	01121	CB2215
R138	315-0472-00			RES., FXD, CMPSN:4.7K OHM, 5%, 0.25W	01121	CB4725
R140	315-0391-00			RES., FXD, CMPSN:390 OHM, 5%, 0.25W	01121	CB3915
R141	315-0122-00			RES., FXD, CMPSN:1.2K OHM, 5%, 0.25W	01121	CB1225
vJ142	315-0222-00			RES., FXD, CMPSN:2.2K OHM, 5%, 0.25W	01121	CB2225
R143	315-0102-00			RES., FXD, CMPSN:1K OHM, 5%, 0.25W	01121	B102OZS
R144	315-0821-00			RES., FXD, CMPSN:820 OHM, 5%, 0.25W	01121	CB821S
R145	315-0123-00			RES., FXD, CMPSN:12K OHM, 5%, 0.25W	01121	CB1235
R146	315-0681-00			RES., FXD, CMPSN:680 OHM, 5%, 0.25W	01121	CB6815
R147	315-0181-00			RES., FXD, CMPSN:180 OHM, 5%, 0.25W	01121	CB1815
R148	315-0472-00			RES., FXD, CMPSN:4.7K OHM, 5%, 0.25W	01121	CB4725
R149	315-0100-00			RES., FXD, CMPSN.10 OHM, 5%, 0.25W	01121	CB1005
R150	315-0103-00			RES., FXD, CPSN:10K OHM, 5%, 0.25W	01121	CB1035
R152	315-0101-00			RES., FXD, CMPSN:100 OHM, 5%, 0.25W	01121	CB1015
R154	315-0223-00			RES., FXD, CMPSN:22K OHM, 5%, 0.25W	01121	CB2235
R155	315-0391-00			RES., FXD, CMPSN:390 OHM, 5%, 0.25W	01121	CB391S
R157	315-0102-00			RES., FXD, CMPSN:1K OHM, 5%, 0.25W	01121	CB1025
R159	315-0510-00			RES., FXD, CMPSN:51 OHM, 5%, 0.25W	01121	CB5105
R160	315-0391-00			RES., FXD, CMPSN:390 OHM, 5%, 0.25W	01121	CB3915
R161	315-0122-00			RES., FXD, CMPSN:1.2K OHM, 5%, 0.25W	01121	CB1225
R162	315-0222-00			RES., FXD, CMPSN:2.2K OHM, 5%, 0.25W	01121	CB2225
R163	315-0102-00			RES., FXD, CMPSN:1K OHM, 5%, 0.25W	01121	CB1025
R164	315-0821-00			RES., FXD, CMPSN:820 OHM, 5%, 0.25W	01121	CB8215
R165	315-0123-00			RES., FXD, CMPSN:12K OHM, 5%, 0.25W	01121	CB1235
R166	315-0681-00			RES., FXD, CMPSN:680 OHM, 5%, 0.25W	01121	CB6815
R168	315-0472-00			RES., FXD, CMPSN:4.7K OHM, 5%, 0.25W	01121	CB4725
R301	307-0106-00			RES., FXD, CMPSN:4.7 OHM, 5%, 0.25W	01121	CB47G5
R303	307-0106-00			RES., FXD, CMPSN:4.7 OHM, 5%, 0.25W	01121	CB47G5
R305	307-0103-00			RES., FXD, CMPSN:2.7 OHM, 5%, 0.25W	01121	CB27G5
R307	321-0069-00			RES., FXD, FILM:51.1 OHM, 1%, .0.125W	75042	CEAT0-51R10F
R308	321-0069-00			RES., FXD, FILM:51.1 OHM, 1%, 0.125W	75042	CEAT0-51R10F
R310	315-0103-00			RES., FXD, CMPSN:10K OHM, 5%, 0.25W	01121	CB1035
R312	315-0562-00			RES., FXD, CMPSN:5.6K OHM, 5%, 0.25W	01121	CB5625
R314	315-0103-00			RES., FXD, CMPSN:10K OHM, 5%, 0.25W	01121	CB1035
R315	315-0513-00			RES., FXD, CMPSN:51K OHM, 5%, 0.25W	01121	CB5135
m317	321-0069-00			RES., FXD, FILM:51.1 OHM, 1%, 0.125W	75042	CEAT0-S1R10P
R319	321-0069-00			RES., FXD, FILM:51.1 OHM, 1%, 0.125W	75042	CEAT0-S1R10F
r320	321-0218-00			RES., FXD, FILM:1.82K OHM, %, 0.125W	75042	CEAT0-1821F
R321	321-0061-00			RES., FXD, FILM:42.2 OHM, 1%, 0.125W	75042	CEAT0-42R20F
R322	315-0101-0			RES., FXD, CMPSN:100 OHM, 5%, 0.25W	01121	CB1015
a323	321-0061-00			RES., FXD, FILM:42.2 OHM, 1%, 0.125W	75042	CEAT0-42R20F
r324	322-0184-00			RES., FXD, FILM:806 OHM, 1, 0.25W	75042	CEBT0-8060F
R326	321-0061-00			RES., FXD, FILM:42.2 OHM, 1%, 0.125W	75042	CEAT0-42R20F

Electrical Parts List-7623A/R7623A Service

Ckt No.	Tektronix Part No.	Serial/Model No. Eff	Dscont	Name & Description	Mfr Code	Mfr Part
R327	322-0184-00			RES., FXD, FILM:806 OHM, 1%, 0.2SW	75042	CEBT0-8060F
R328	321-0061-00			RES., FXD, FILM:42.2 OHM, 1%, 0.25W	75042	CEATO-42R20F
R329	315-0101-00			RES., FXD, CMPSN:100 OHM, 5, 0.25W	01121	CB1015
R330	321-0049-00			RES., FXD, FILM:31.6 OHM, 1%, 0.125W	75042	CEATO-31R60F
R332	321-0220-00			RES., FXD, FILM:1.91K OHM, 1%, 0.125W	75042	CEATO-1911F
R333	321-0143-00			RES., FXD, FILM:301 OHM, 1%, 0.125W	75042	CEATO-3010F
R334	321-0082-00			RES., FXD, FILM:69.8 OHM, 1%, 0.125W	75042	CEATO-69R80F
R335	321-0049-00			RES., FXD, FILM:31.6 OHM, 1%, 0.125SW	75042	CEATO-31R60F
R336	321-0129-00			RES., FXD, FILM:215 OHM, 1%, 0.125W	75042	CEATO-2150F
R337	321-0129-00			RES., FXD, FILM:215 OHM, 1, 0.12W	75042	CEATO-2150F
R338	321-0069-00			RES., FXD, FILM51.1 OHM, 1, 0.125W	75042	CEATO-51R10P
R339	321-0069-00			RES., FXD, FILM:51.1 OHM, 1%, 0.125W	75042	CEATO-51R10F
R340	321-0214-00			RES., FXD, FILM 1.65K OHM, 1%, 0.125W	75042	CEATO-1651F
R341	315-0680-00			RES., FXD, CMPSN:68 OHM, 5%, 0.25W	01121	CB6805
R342	315-0331-00			RES., FXD, CMPSN:330 OHM, 5%, 0.25W	01121	CB3315
R344	321-0040-00			RES., FXD, FILM:25.5 OHM, 1%, 0.125W	75042	CEATO-2S5PS
R345	315-0561-00			RES., FXD, CPSN:560 OHM, 5%, 0.25W	01121	CB5615
R346	321-0040-00			RES., FXD, FILM:25.5 OHM, 1%, 0.125W	75042	CEATO-25R5P
R348	315-0331-00			RES., FXD, CMPSN:330 OHM, 5%, 0.25W	01121	CB3315
R349	315-0680-00			RES., FXD, CMPSN:68 OHM, 5%0.	01121	CB6805
R350	321-0214-00			RES., FXD, FILM:1.65K OHM, 1%, 0.125W	75042	CEATO-1651F
R352	315-0430-00			RES., FXD, CMPSN43 OHM, 5%, 0.25W	01121	CB4305
R501	321-1068-01			RES., FXD, FILM:50.5 OHM, 0.5%, 0.125W	75042	CEATO-50R50D
R502	315-0100-00			RES., FXD, CMPSN:10 OHM, 5%, 0.25W	01121	CB1005
R503	321-1068-01			RES., FXD, FILM:50.5 OHM, 0.5%, 0.125W	75042	CEATO-50R50D
R505	321-0291-00	B010100	B059999	RES., FXD, FILM:10.5K OHM, 1%, 0.125W	75042	CEATO-1052F
R505	321-0297-00	B06000		RES., FXD, FILM:12.1K OHM, 1%, 0.125W	75042	CEATO-1212F
R506	321-0069-00			RES., FXD, FILM:51.1 OHM, 1%, 0.125W	75042	CEATO-51R10P
R508	321-0184-00			RES., FXD, FILM:806 OHM, 1%, 0.12SW	75042	CEATO-8060P
R509	321-0069-00			RES., FXD, FILM:S1.1 OHM, 1%, 0.125W	75042	CEATO-51R10P
R511	321-0155-00			RES., FXD, FILM:402 OHM, 1%, 0.125W	75042	CEATO-4020F
R512	311-1224-00			RES., VAR, NONWIR:500 OHM, 20%, 0.50W	80294	3389F-P31-501
R513	321-0150-00			RES., FXD, FILM:357 OHM, 1%, 0.125W	75042	CEATO-3570P
R514	323-0253-00			RES., FXD, FILM:4.22K OHM, 1, 0.50W	75042	CECTO-4221F
R515	323-0253-00			RES., FXD, FILM:4.22K OHM, 1%0.50W	75042	CECTO-4221F
R517	321-0212-00			RES., FXD, FILM:1.58K OHM, 1%, 0.125W	75042	CEATO-1581F
R519	321-0119-00			RES., FXD, FILM:169 OHM, 1%, 0.125W	75042	CEATO-1690F
R521	321-0261-00			RES., FXD, FILM:5.11K OHM, 1%, 0.125W	75042	CEATO-5111F
R522	321-0261-00			RES., FXD, FILM:5.11K OHM, 1%, 0.125W	75042	CEATO-5111F
R524	321-0236-00			RES., FXD, FILM:2.K OHM, 1%, 0.125W	75042	CEATO-2801F
RS25	311-1223-00			RES., VAR, NONWIR:Z50 OHM, 10%, 0.5W	80294	3386F-T04-251
R526	321-0236-00			RES., FXD, FILM:2.8K OHM, 1%, 0.125W	75042	CEATO-2801F
R529	315-0473-00			RES., CMPSN:47K OHM, 5%, 0.25W	01121	CB4735
R531	323-0253-00			RES., FXD, FILM:4.22K OHM, 1%, 0.50W	75042	CECTO-4221F
R532	323-0253-00			RES., FXD, FILM:4.22K OHM, 1%, 0.50W	75042	CECTO-4221F
RS34	321-0269-00			RES., FXD, FILM:6.19K OHM, 19, 0.12SW	75042	CEATO -6191F
R535	311-1225-00			RES., VAR, NONWIR:1K OHM, 20%, 0.50W	80294	3389F-P31-102
R536	321-0269-00			RES., FXD, FILM:6.19K OHM, 1%, 0.125W	75042	CEATO-6191F
R540	321-0236-00			RES., FXD, FILM:2.8K OHM, 1, 0.125W	75042	CEATO-2801F
R542	315-0300-00			RES., FXD, CPSN:30 OHM, 5%, 0.25W	01121	CB3005
R543	321-0193-00			RES., FXD, FILM:K OHM, 1%, 0.125W	75042	CEATO-1001F
R544	315-0300-00			RES., FXD, CMPSN:30 OHM, 5%, 0.25W	01121	CB3005
RS48	321-0236-00			RES., FXD, FILM:2.SK OHM, 1%, .125W	75042	CEATO-2801F

Electrical Parts List-7623A/R7623A Service

Ckt No. Number	Tektronix	Serial/Model No.		Name & Description	Mfr Code	Mfr Part
	Part No.	Eff	Dscont			
R549	315-0102-00			RES., FXD, CMPSN:1K OHM, 5%, 0.25W	01121	CB1025
R551	308-0243-00			RES., FXD, WW:240 OHM, 5%, 3W	91637	RS2B-B240R0J
R55	315-0470-00			RES., FXD, CMPSN:47 OHM, 5%, 0.25W	01121	CB4705
R556	301-0393-00			RES., FXD, CMPSN:39K OHM, 5%, 0.5W	01121	EB3935
R558	323-0231-00			RES., FXD, FILM:2.49K OHM, 1%, 0.50W	75042	CECT0-2491F
R559	315-0100-00			RES., FXD, CMPSN:10 OHM, 5%, 0.25W	01121	CB1005
R560	315-0104-00			RES., FXD, CMPSN:100K OHM, 5%, 0.25W	01121	CB1045
R561	315-0100-00			RES., FXD, CMPSN:10 OHM, 5%, 0.25W	01121	CB10050
R562	323-0114-00			RES., FXD, FILM:150 OHM, 1%, 0.50W	75042	CECT0-1500F
R563	323-0066-00			RES., FXD, FILM:47.5 OHM, 1%, 0.50W	75042	CECT0-47R50F
R565	315-0101-00			RES., FXD, CMPSN:100 OHM, 5%, 0.25W	01121	CB1015
R566	323-0301-00			RES., FXD, FILM:13.3K OHM, 1%, 0.50W	75042	CECT0-1332F
R567	323-0300-00			RES., FXD, FILM:13K OHM, 1%, 0.50W	75042	CECT0-1302F
R569	321-0143-00			RES., FXD, FILM:301 OHM, 1%, 0.125W	75042	CEAT0-3010F
R570	321-0314-00			RES., FXD, FILM:18.2K OHM, 1%, 0.125W	75042	CEAT0-1822F
R571	321-0246-00			RES., FXD, FILM:3.57K OHM, 1%, 0.125W	75042	CEAT0-3571F
R573	321-0273-00			RES., FXD, FILM:6.81K OHM, 1%, 0.125W	75042	CEAT0-6811F
R574	323-0352-00			RES., FXD, FILM:45.3K OHM, 1%, 0.50W	75042	CECT0-4532F
R575	315-0470-00			RES., FXD, CMPSN:47 OHM, 5%, 0.25W	01121	CB4705
R576	301-0393-00			RES., FXD, CMPSN:39K OHM, 5%, 0.50W	01121	EB3935
R578	323-0231-00			RES., FXD, FILM 2.49K OHM, 1%, 0.50W	75042	CECT0-2491F
R579	315-0100-00			RES., FXD, CMPSN:10 OHM, 5%, 0.25W	01121	CB1005
R580	315-0104-00			RES., FXD, CMPSN:100K OHM, 5%, 0.25W	01121	CB1045
R581	315-0100-00			RES., FXD, CMPSN:10 OHM, 5%, 0.2W	01121	CB1005
R582	323-0114-00			RES., FXD, FILM150 OHM, 1%, 0.50W	75042	CECT0-1500F
R583	323-0066-00			RES., FXD, FILM:47.5 OHM, 1%, 0.50W	75042	CECT0-47R50F
R584	315-0684-00			RES., FXD, CMPSN:680K OHM, 5%, 0.25W	01121	CB6845
R585	315-0101-00			RES., FXD, CMPSN:100 OHM, 5%, 0.25W	01121	CB1015
R586	323-0301-00			RES., FXD, FILM:13.3K OHM, 1%, 0.50W	75042	CECT0-1332F
R587	323-0300-00			RES., FXD, FILM:13K OHM, 1%, 0.50W	75042	CECT0-1302F
R589	321-0143-00			RES., FXD, FILM:301 OHM, 1%, 0.125W	75042	CEAT0-3010F
R593	315-0100-00			RES., FXD, CMPSN:10 OHM, 5%, 0.25W	01121	CB1005
R595	307-0106-00			RES., FXD, CPSN:4.7 OHM, 5%, 0.25W	01121	CB47G05
R597	315-0100-00			RES., FXD, CMPSN:10 OHM, 5%, 0.25W	01121	CB1005
R598	307-0106-00			RES., FXD, CMPSN:4.7 OHM, 5%, 0.25W	01121	CB47G5
R599	307-0103-00			RES. FXD, CMPSN:2.7 OHM, 5%, 0.25W	01121	CB27G5
R602	315-0101-00			RES., FXD, CMPSN:100 OHM, 5%, 0.25W	01121	CB1015
R605	315-0561-00			RES., FXD, CMPSN:560 OHM, 5%, 0.25W	01121	CB5615
R607	321-0020-00			RES., FXD, FILM.15.8 OHM, 1%, 0.125W	75042	CEAT0-15R80F
R608	321-0089-00			RES., FXD, FILM:82.5 OHM, 1%, 0.125W	75042	CEAT0-82R50P
R610	307-0106-00			RES., FXD, CMPSN:4.7 OHM, 5%, 0.25W	01121	CB47G5
R612	321-0193-00	B010100	B119999	RES., FXD, FILM:500 OHM, 1%, 0.125.	750-4	CEAT0-10 01F
R612	321-0612-00	B20000		RES., FXD, FILM:500 OHM, 1%, 0.125W	91637	MFF1816D5000F
R613	321-0222-00	B010100	B119999	RES., FXD, FILM:2 OHM, 1%, 0.125	75042	CEAT0-2001F
R613	321-0193-00	BZ20000		RES., FXD, FILM:1K OHM, 1%, 0.12W	75042	C1-1001
R615	315-0240-00			RES., FXD, CMPSN:24 OHM, 5%, 0.25W	01121	CB2405
R617	321-0020-00			RES., FXD, FILM:15.8 OHM, 1%, 0.125W	75042	CEAT0-15R80F
R619	315-0101-00			RES., FXD, CMPSN:100 OHM, 5%, 0.25W	01121	CB1015
R622	321-0208-00			RES., FXD, FILM:1.43K OHM, 1%, 0.125W	75042	CEAT0-1431F
R623	307-0106-00			RES., FXD, CMPSN:4.7 OHM, 5%, 0.25W	01121	CB47G5
R625	321-0224-00			RES., FXD, FILM:2.1K OHM, 1%, 0.125W	75042	CEAT0-2101F
R627	315-0101-00			RES., FXD, CMPSN:100 OHM, 5%, 0.25W	01121	CB1015
R630	315-0101-00			RES., FXD, CMPSN:100 OHM, 5%, 0.25W	01121	CB1015
R633	315-0222-00			RES., FXD, CMPSN:-2.2K OHM, 5%, 0.25W	01121	CB2225
R636	315-0241-00			RES., FXD, CMPSN:240 OHM, 5%, 0.25W	01121	CB2415

Electrical Parts List-7623A/R7623A Service

Ckt No. Number	Tektronix	Serial/Model No.		Name & Description	Mfr Code	Mfr Part
	Part No.	Eff	Dscont			
R637	315-0152-00			RES., FXD, CMPSN:1.SK OHM, 5%, 0.25W	01121	CB1525
R639	315-0101-00			RES., FXD, CMPSN 100 OHM, 5%, 0.25W	01121	CB1015
R641	315-0272-00			RES., FXD, CMPSN 2.7K OHM, 5%, 0.25W	01121	CB2725
R643	315-0220-00			RES., FXD, CMPSN:322 OHM, 5%, 0.25W	01121	CB2205
R645	321-0260-00			RES., FXD, FILM:4.99K OHM, 1%, 0.125W	75042	CEAT0-4991F
R647	321-0190-00			RES., FXD, FILM:931 OHM, 1%, 0.125W	75042	CEAT0-9310F
R651	315-0201-00			RES., FXD, CMPSN:200 OHM, 1%, 0.25W	01121	CBZ015
R652	315-0123-00			RES., FXD, CMPSN:12K OHM, 5%, 0.2W	01121	CB1235
R654	315-0201-00			RES., FXD, CMPSN:200 OHM, 5%, 0.25W	01121	CBZ015
R655	315-0123-00			RES., FXD, CMPSN:12K OHM, 5%, 0.25W	01121	CB1235
R657	315-0201-00			RES., FXD, CMPSN:200 OHM, 5%, 0.25W	01121	CB2015
R658	315-0123-00			RES., FXD, CMPSN:12K OHM, 5%, 0.25W	01121	CB1235
R660	315-0101-00			RES., FXD, CMPSN:100 OHM, 5%, 0.25W	01121	CB1015
R662	315-0821-00			RES., FXD, CMPSN 820 OHM, 5%, 0.25W	01121	CB8215
R663	321-0193-00			RES., FXD, FILM: 1K OHM, 1%, 0.125W	75042	CEAT0-1001F
R667	315-0561-00			RES., FXD, CMPSN560 OHM, 5%, 0.5W	01121	CB5615
R669	307-0106-00			RES., FXD, CMPSN:4.7 OHM, 5%, 0.25W	01121	CB47GS
R670	321-0143-00			RES., FXD, FILM:301 OHM, 1%, 0.125W	75042	CEAT0-3010 F
R672	321-0180-00			RES., FXD, FILM:732 OM, 1%, 0.125W	75042	CEAT0-732OF
R673	321-0226-00			RES., FXD, FILM:2.21K OHM, 1%, 0.125W	75042	CEAT0-2211F
R675	321-0189-00			RES., FXD, FILM:909 OHM, 1%, 0.125W	75042	CEAT0-9090F
R677	315-0390-00			RES., FXD, CMPSN:39 OHM, 5%, 0.25W	01121	CB3905
R679	307-0106-00			RES., FXD, CMPSN:4.7 OHM, 5%, 0.2W	01121	CB47G05
R805	307-0113-00	B010100	B019999X	RES., FXD, CMPSN:5.1 OHM, 5%, 0.2W	01121	CB51G5
R806	302-0473-00			RES., FXD, CMPSN:47K OHM, 10%, 0.50W	01121	EB4731
R808	302-0223-00			RES., FXD, CMPSN:22K OH, 10%, 0.50W	01121	EB2231
R809	302-0223-00			RES., FXD, CMPSN:22K OHM, 10%, 0.50W	01121	EB2231
R811	302-0472-00			RES., FXD, CMPSN:4.7K OHM, 10%, 0.50W	01121	EB4721
R814	302-0472-00			RES., FXD, CMPSN:4.7K OHM, 10%, 0.50W	01121	EB4721
R821	302-0472-00			RES., FXD, CMPSN:4.7K OHM, 10%, 0.50W	01121	EB4721
R822	315-0102-00			RES., FXD, CMPSN: 1K OHM, 5%, 0.2W	01121	CB1025
R823	315-0151-00			RES., FXD, CMPSN:150 OHM, 5%, 0.25W	01121	CB1515
R824	315-0470-00			RES., FXD, CMPSN:47 OHM, 5%, 0.25W	01121	CB4705
R826	315-0302-00			RES., FXD, CMPSN:3K OHM, 5%, 0.25W	01121	CB3025
R827	315-0472-00			RES., FXD, CMPSN:4.7K OHM, 5%, 0.25W	01121	CB4725
R830	315-0911-00			RES., FXD, CMPSN:910 OHM, 5%, 0.2SW	01121	CB9115
R831	315-0392-00			RES., FXD, CMPSN:3.9K OHM, 5%, 0.2W	01121	CB3925
R833	315-0683-00			RES., FXD, CMPSN:68K OH, 5%, 0.25SW	01121	CB6835
R837	307-0054-00			RES., FXD, CMPSN:3.6 OHM, 5%, 0.50W	01121	EB36GB
R838	307-0054-00			RES., FXD, CMPSN:3.6 OHM, 5%, 0.50W	01121	E36GB
R853	315-0473-00			RES., FXD, CMPSN:47K OHM, 5%, 0.25W	01121	CB4735
R855	323-0309-00			RES., FXD, FILM:16.2K OM, 1%, 0.50W	75042	CECT0-1622F
R8S6	323-0289-00			RES., FXD, FILM:10K OHM, 1%, 0.50W	75042	CECT0-1002F
R858	321-0924-07			RES., FXD, FILM:40K OHM, 0.1%, 0.125W	75042	CEAT9-4002B
R859	321-0924-07			RES., FXD, FILM:40K OHM, 0.1%, 0.125W	75042	CEAT9-4002B
R860	315-0684-00			RES., FXD, CMPSN:680K OHM, 5%, 0.25W	01121	CB6845
R862	315-0204-00			RES., FXD, CMPSN:200K OHM, 5%, 0.25W	01121	CB2045
R864	315-0203-00			RES., FXD, CMPSN:20K OHM, 5%, 0.25W	01121	CB2035
R866	315-0332-00			RES., FXD, CMPSN:3.3K OHM, 5%, 0.25W	01121	CB3325
R867	315-0824-00			RES., FXD, CMPSN:820K OHM, 5%, 0.25 W	01121	CB8245
R870	315-0122-00			RES., FXD, CMPSN:1.2K OHM, 5%, 0.5W	01121	CB1225
R872	315-0151-00			RES., FXD, CMPSN:150 OHM, 5%, 0.5W	01121	CB1515
R875	308-0677-00			RES., FXD, WW:1 OHM, 5%, 2W	75042	BWH-1R000J

Electrical Parts List-7623A/R7623A Service

Ckt No. Number	Tektronix Part No.	Serial/Model No.		Name & Description	Mfr Code	Mfr Part
		Eff	Dscont			
R876	315-0824-00			RES., FXD, CMPSN:820K OHM, 5%, 0.25W	01121	CB245
R877	315-0511-00			RES., FXD, CHPSN:510 OHM, 5%, 0.25W	01121	CB5115
R878	315-0104-00			RES., FXD, CMPSN:100K OHM, 5%, 0.25W	01121	CB1045
R879	315-0124-00			RES., FXD, CMPSN:120K OHM, 5%, 0.2W	01121	CB1245
R880	323-0272-00			RES., FXD, FILM:6.65K OHM, 1%, 0.50W	75042	CECT0-6651F
R881	311-1223-00			RES., VAR, NONWIR:250 OHM, 10%, .50W	80294	3386F-T04-251
R882	323-0206-00			RES., FXD, FILM:1.37K OHM, 1%, 0.50W	75042	CECT0-1371F
R883	321-0223-00			RES., FXD, FILM:2.05K OHM, 1%, 10.12W	75042	CEAT0-2051F
R884	323-0306-00			RES., FXD, FILM:15K OHM, 1%, 0.50W	75042	CECT0-1502F
R886	315-0224-00			RES., FXD, CMPSN:220K OHM, 5%, 0.2W	01121	CB2245
R889	315-0911-00			RES., FXD, CMPSN:910 OHM, 5%, 0.25W	01121	CB9115
R890	323-0264-00			RES., FXD, FILM:5.49K OHM, 1%, 0.50W	75042	CECT0-5491F
R891	315-0473-00			RES., FXD, CMPSN:47K OHM, 5%, 0.25W	01121	CB4735
R892	315-0682-00			RES., FXD, CMPSN:6.8K OHM, 5%, 0.25W	01121	CB6825
R894	315-0245-00			RES., FXD, CMPSN:2.4H OHM, 5%, 0.25W	01121	CB2455
R896	301-0363-00			RES., FXD, CMPSN:36K OHM, 5%, 0.50W	01121	EB3635
R898	315-0182-00			RES., FXD, CMPSN:1.8K OHM, 5%, 0.25W	01121	CB1825
R901	315-0151-00			RES., FXD, CMPSN:150 OHM, 5%, 0.25W	01121	CB1515
R903	308-0677-00			RES., FXD, WW:1 OHM, 5%, 2W	75042	BWH-1R000J
R904	308-0679-00			RES., FXD, WW:0.51 OHM, 5%, 2W	75042	BWH-R5100J
R906	315-0304-00			RES., FXD, CMPSN:300K OHM, 5%, 0.25W	01121	CB3045
R907	315-0753-00			RES., FXD, CMPSN:75K OHM, 5%, 0.25W	01121	CB7535
R908	315-0431-00			RES., FXD, CMPSN:430 OHM, 5%, 0.25W	01121	CB4315
R910	315-0681-00			RES., FXD, CMPSN:680 OHM, 5%, 0.25W	01121	CB6815
R911	315-0563-00			RES., FXD, CMPSN:56K OHM, 5%, 0.25W	01121	CB5635
R912	315-0182-00			RES., FXD, CMPSN:1.8K OHM, 5%, 0.2W	01121	CB1825
R915	321-1296-07			RES., FXD, FILM:12K OHM, 0.1%, 0.125W	75042	CEAT9-1202B
R916	321-0924-07			RES., FXD, FILM:40K OHM, 0.1%, 0.125W	75042	CEAT9-4002B
R918	301-0683-00			RES., FXD, CMPSN:68K OHM, 5%, 0.50W	01121	EB6835
R921	315-0912-00			RES., FXD, CMPSN :9.K OHM, 5%, 0.25W	01121	CB9125
R922	315-0623-00			RES., FXD, CMPSN:62K OHM, 5%, 0.25W	01121	C6235
R923	315-0512-00			RES., FXD, CMPSN:5.K ORM, 5%, 0.25W	01121	CB5125
R924	315-0623-00			RES., FXD, CMPSN:62K OHM, 5%, 0.25W	01121	C6235
R927	315-0472-00			RES., FXD, CMPSN:4.7K OM, 5%, 0.25W	01121	CB4725
R932	315-0182-00			RES., FXD, CMPSN:1.8K OHM, 5%, 0.25W	01121	CB1825
R935	308-0678-00			RES., FXD, WW:0.1 OHM, 5%, 2W	75042	BH-R100J
R936	301-0273-00			RES., FXD, CMPSN:27K OHM, 5%, 0.SW	01121	EB2735
R937	321-0151-00			RES., FXD, FILM:365 OHM, 1%, 0.125W	75042	CEATO-3600F
R938	321-0330-00			RES., FXD, FILM:26.7K OHM, 1%, 0.125W	75042	CEATO-2672F
R939	321-0409-00			RES., FXD, FILM:178K OHM, 1%, 0.125W	75042	CEATO-1783F
R940	315-0822-00			RES., FXD, CMPSN:8.2K OHM, 5%, 0.25W	01121	CB822
R942	315-0154-00			RES., FXD, CMPSN:10SK OHM, 5%, 0.2W	01121	CB1545
R945	321-0332-07			RES., FXD, FILM:28K OHM, 0.1%, 0.125W	75042	CEAT9-2802B
R946	321-1296-07			RES., FXD, FILM:1K OHM, 0.1%, 0.125W	75042	CEAT9-1202B
R948	315-0914-00			RES., FXD, CMPSN:910K OHM, 5%, 0.2W	01121	CB9145
R950	315-0681-00			RES., FXD, CMPSN:680 OHM, 5%, 0.25W	01121	CB6815
R952	301-0303-00			RES., FXD, CMPSN:30K OHM, 5%, 0.50W	01121	EB3035
R954	315-0472-00			RES., FXD, CMPSN:4.7K OHM, 5%, 0.25W	01121	CB4725
R956	307-0103-00			RES., FXD, CMPSN:2.7 OHM, 5%, 0.25W	01121	CB27G5
R957	315-0151-00	B010100	B142121	RES., FXD, CMPSN:150 OHM, 5%, 0.25W	01121	CB1515
R957	315-0510-00	B142122		RES., FXD, CMPSN:510HM, 5%, 0.2W	01121	CB5105
R958	308-0678-00			RES., FXD, WW:0.10HM, 5%, 2W	75042	BWM-R000J
R959	308-0680-00			RES., FXD, WW:0.045 OHM, 10%, 3W	91637	LVR2-DR0450K
R961	315-0221-00			RES., FXD, CMPSN:220 OHM, 5%, 0.25W	01121	CB2215

Electrical Parts List-7623A/R7623A Service

Ckt No. Number	Tektronix Part No.	Serial/Model No.		Name & Description	Mfr Code	Mfr Part
		Eff	Dscont			
R963	315-0682-00			RES., FXD, CMPSN:6.8K OHM, 5%, .25W	01121	CB6825
R966	315-0123-00			RES., FXD, CMPSN:12K OHM, 5%, 0.25W	01121	CB1235
R967	315-0364-00			RES., FXD, CMPSN:360K OHM, 5%, 0.25W	01121	CB3645
R970	321-0926-07			RES., FXD, FILM:4K OHM, 0.1% , 0.125W	75042	CEAT9-4001B
R971	321-0924-07			RES., FXD, FILM:40K OHM, 0.1%, 0.125W	75042	CEAT9-4002B
R973	315-0683-00			RES., FXD, CMPSN:68K OHM, 5%, 0.25W	01121	CB6835
R974	315-0303-00			RES., FXD, CMPSN:30K OHM, 5%, 0.25W	01121	CB3035
R975	315-0362-00			RES., FXD, CMPSN:3.6K OHM, 5%, 0.25W	01121	CB3625
R977	315-0184-00			RES., FXD, CMPSN:180K OHM, 5%, 0.25W	01121	CB1845
R979	315-0822-00			RES., FXD, CMPSN:8.2K OHM, 5%, 0.25W	01121	CB8225
R980	315-0164-00			RES., FXD, CMPSN:160K OHM, 5%, 0.25W	01121	CB1645
R983	315-0472-00			RES., FXD, CMPSN:4.7K OHM, 5%, 0.2W	01121	CB4725
R985	304-0470-00			RES., FXD, CMPSN:47 OHM, 10%, 1W	01121	GB4701
R986	315-0122-00			RES., FXD, CMPSN:1.2K OHM, 5%, 0.25W	01121	CB1225
R989	308-0678-00			RES., FXD, WW:0.1 HM, 5%, 2W	75042	BWH-R1000
R991	315-0753-00			RES., FXD, CMPSN:75K OHM, 5%, 0.25W	01121	CB7535
R993	315-0241-00			RES., FXD, CMPSN:240 OHM, 5%, 0.25W	01121	CB2415
R994	315-0124-00			RES., FXD, CMPSN:120K OHM, 5%, 0.2SW	01121	CB1245
R995	315-0562-00			RES., FXD, CMPSN:5.6K OHM, 5%, 0.25W	01121	CB5625
R1018	315-0102-00			RES., FXD, CMPSN:1K OHM, 5%, 0.25W	01121	CB1025
R1019	315-0102-00			RES., FXD, CMPSN:1K OHM, 5%, 0.25W	01121	CB1025
R1020	315-0150-00	B010100	B059999	RES., FXD, CMPSN:15 OHM, 5%, 0.25W	01121	CB1505
R1020	307-0107-00	B060000		RES., FXD, CMPSN:5.6 OHM, 5%, 0.25W	01121	CB56G5
R1022	315-0303-00			RES., FXD, CMPSN:30K OHM, 5%, 0.25W	01121	CB3035
R1095	311-1055-00			RES., VAR, NONWIR:K OHM 20%, 0.50W	12697	CM 40034
R1101	315-0470-00			RES., FXD, CMPSN:47 OHM, 5%, 0.25W	01121	CB4705
R1103	315-0471-00			RES., FXD, CMPSN:470 OHM 5%, 0.25SW	01121	CB4715
R1106	315-0103-00			RES., FXD, CMPSN:10K OHM, 5%, 0.2SW	01121	CB1035
R1107	315-0123-00			RES., FXD, CMPSN:1K OHM, 5%, 0.25W	01121	CB1235
R1115	315-0392-00	B010100	B109999	RES., FXD, CMPSN:3.9K OHM, 5%, 0.25SW	01121	C3925
R1115	317-0392-00	B110000		RES., XD, CMPSN:3.9K OHM, 5%, 0.12W	01121	BB3925
R1116	323-0312-00			RES., FXD, FILM:17.4K OHM, 1%, 0.50W	75042	CECT0-1742F
R1118	315-0121-00			RES., FXD, CMPSN:120 OHM, 5%, 0.2SW	01121	CB1215
R1120	315-0203-00			RES., FXD, CMPSN:20K OHM, 5%, 0.25W	01121	CB2035
R1121	315-0562-00			RES., FXD, CMPSN:5.6K OHM, 5%, 0.25SW	01121	CB5625
R1123	315-0392-00			RES., FXD, CMPSN:3.9K OHM, 5%, 0.25W	01121	CB3925
R1124	315-0100-00			RES., FXD, CMPSN.10 OHM, 5%, 0.25W	01121	CB1005
R1125	315-0102-00			RES., FXD, CMPSN:1K OHM, 5%, 0.25W	01121	CB1025
R1127	315-0102-00			RES., FXD, CMPSN:1K OHM, 5%, 0.2W	01121	CB1025
R1130	321-0325-00			RES., FXD, FILM:23.7K OHM, 1%, 0.125W	75042	CEAT0-2372F
R1131	315-0513-00			RES., FXD, CMPSN-51K OHM, 5%, 0.25W	01121	CB5135
R1133	321-0311-00			RES., FXD, FILM:16.9K OHM, 1%, 0.12W	75042	CEAT0-1692F
R1135	315-0470-00			RES., FXD, CMPSN:47 OHM, 5%, 0.25W	01121	CB4705
R1144	315-0623-00			RES., FXD, CMPSN:62K OHM, 5%, 0.25W	01121	CB6235
R1147	311-1228-00			RES., VAR, NONWIR:10K OHM, 20%, 0.50	80294	3389F-P31-103
R1152	315-0621-00			RES., FXD, CMPSN:620 OHM, 5%, 0.25W	01121	CB6215
R1154	315-0183-00			RES., FXD, CMPSN:5K OHM, 5 %, 0.25W	01121	CB1835
R1157	321-0336-00			RES., FXD, FILM:30.9 OHM, 1%, 0.12W	75042	CEAT0-3092F
R1158	321-0362-00			RES., FXD, FILM:57.6K OHM, 1%, 0.125W	75042	CEAT0-5762F
R1159	321-0441-00			RES., FXD, FILM:383K OHM, 1%, 0.125W	75042	CEAT0-3833F
R1161	315-0103-00			RES., FXD, CMPSN:10K OHM, 5%, 0.2W	01121	CB1035
R1162	315-0244-00			RES., FXD, CMPSN:240K OHM, 5%, 0.25W	01121	B2445
R1164	315-0822-00			RES., FXD, CMPSN:8.2K OHM, 5%, 0.25W	01121	CB8225
R1166	315-0121-00			RES., FXD, CMPSN:120 OHM, 5%, 0.25W	01121	CB1215

¹Furnished as a unit with S1095.

REV. C FEB. 1977

Electrical Parts List-7623A/R7623A Service

Ckt No. Number	Tektronix Part No.	Serial/Model No.		Name & Description	Mfr Code	Mfr Part
		Eff	Dscont			
R1168	315-0101-00			RES., FXD, CMPSN:100 OHM, 5, 0.25W	01121	CB1015
R1182	315-0103-00			RES., FXD, CMPSN:10K OHM, 5%, 0.2W	01121	CB1035
R1183	315-0102-00			RES., FXD, CMPSN:1K OHM, 5%, 0.25W	01121	CB1025
R1184	315-0473-00			RES., FXD, CMPSN:47K OHM, 5%, 0.25W	01121	CB4735
R1185	315-0474-00			RES., FXD, CPSN:470K OHM, 5%, 0.25W	01121	CB4745
R1188	315-0102-00			RES., FXD, CMPSN:1K OHM, 5%, 0.25W	01121	CB1025
R1189	315-0104-00			RES., FXD, CMPSN:100K OHM, 5, 0.25W	0 1121	CB1045
R1192	315-0562-00			RES., FXD, CMPSN:5.6K OHM, 5%, 0.2W	01121	CB5625
R1204	301-0305-00			RES., FXD, CMPSN:3M OHM, 5%, 0.50W	01121	EB3055
R1205	301-0305-00			RES., FXD, CMPSN3M OHM, 5%, 0.50W	01121	EB3055
R1206	301-0305-00			RES., FXD, CMPSN 3M OHM, 5%, 0.50W	01121	EB3055
R1207	301-0305-00			RES., FXD, CMPSN:3M OHM, 5%, 0.50W	01121	EB3055
R1208	301-0305-00			RES., FXD, CMPSN:3M OHM, 5%, 0.50W	01121	EB3055
R1214	315-0103-00			RES., FXD, CMPSN-100K OHM, 5%, 0.25W	01121	CB1035
R1219	315-0302-00			RES., FXD, CMPSN:3K OHM, 5%, 0.25W	01121	CB3025S
R1221	316-0825-00			RES., FXD, CPSN:8.2M OHM, 10%, 0.25W	01121	CB8251
R1223	315-0434-00			RES., FXD, CMPSN:430K OHM, 5%, 0.2W	01121	CB4345
R1224	315-0101-00			RES., FXD, CPSN:100 OHM, 5%, 0.2W	01121	CB1015
R1226A, B	307-0386-03			RES., FXD, FILM:HYBRID	80009	307-0386-03
R1226C, D						
R1230	311-1584-00			RES., VAR, NONIR:S50K OHM, 10%, 0.50W	12697	382CH40221
R1232	315-0103-00			RES., FXD, CMPSN:10K OHM, 5%, 0.25W	01121	CB1035
R1233	315-0103-00			RES., FXD, CMPSN:10K OHM, 5%, 0.2W	01121	CB1035
R1235	315-0754-00			RES., FXD, CMPSN:750K OHM, 5%, 0.2SW	01121	CB7545
R1236	315-0754-00			RES., FXD, CMPSN:750K OHM, 5%, 0.25W	01121	CB7545
R1239	315-0915-00			RES., FXD, CMPSN:9.M OHM, 5%, 0.25W	01121	CB9155
R1240	315-0103-00			RES., FXD, CMPSN:10K OHM, 5%, 0.25W	01121	CB1035
R1242	311-1257-00			RES., VAR, NONWIR:5M OHM, 20%, 0.50W	80294	3386F-T04-505
R1245	321-0486-00			RES., FXD, FILM:1.13M OHM, +/-1%, 0.125W75042	CEAT0-1134F	
R1246 ¹						
R1248	311-1233-00			RES., VAR, NONWIR:50K OHM, 10%, 0.50W	80294	3386F-TO5-503
R1250	315-0103-00			RES., FXD, CMPSN:10K OHM, 5, 0.25W	01121	CB1035
R1251	315-0103-00			RES., FXD, CMPSN:10K OHM, 5%, 0.25W	01121	CB1035
R1253	315-0754-00			RES., FXD, CMPSN:750K OHM, 5%, 0.25W	01121	CB7545
R1254	315-0754-00			RES., FXD, CMPSN:750K OHM, 5%, 0.25W	01121	CB7545
R1258	315-0915-00			RES., FXD, CMPSN:9.1M OM, 5%, 0.25W	01121	CB9155
R1259	315-0103-00			RES., FXD, CMPSN:10K OHM, 5, 0.25W	01121	CB1035
R1261	315-0104-00			RES., FXD, CMPSN:100K OM, S%, 0.25W	01121	CB1045
R1263	315-0474-00			RES., FXD, CMPSN:470K OHM, 5%, 0.25 W	01121	CB4745
R1270	315-0362-00			RES., FXD, CMPSN:3.6K OHM, 5%, 0.25W	01121	CB3625
R1271	315-0362-00			RES., FXD, CMPSN:3.6K OHM, 5%, 0.25W	01121	C83625
R1272 ¹						
R1274	311-1235-00			RES., VAR, NONWIR:100K OHM, 20%, 0.50W	80294	3389F-P31-104
R1284	311-1227-00			RES., VAR, NONWIR:5K OHM, 20%, 0.5W	80294	3389F-P31-502
R1286	311-1583-00			RES., VAR, NONWIR:SK OHM, 10%, 0.50W	01121	F-8195
R1291 ¹						
R1292	311-1235-00			RES., VAR, NONWIR:100K OHM, 20, 0.50W	80294	3389F-P31-104
R1410	315-0103-00			RES., XD, CMPSN:10K OHM, 5%, 0.2W	01121	CB1035
R1411	315-0274-00			RES., FXD, CMPSN:270K OHM, 5, 0.25W	01121	CB2745
R1412	315-0472-00			RES., FXD, CMPSN:4.7K OHM, 5%, 0.25W	01121	CB4725
R1414	315-0472-00			RES., FXD, CMPSN:4.7K OHM, 5%, 0.25W	01121	CB4725
R1415	315-0103-00			RES., FXD, CMPSN:10K OHM, 5%, 0.25W	01121	CB1035
R1416	315-0332-00			RES., FXD, CMPSN:3.3K OHM, 5%, 0.25W	01121	CB3325

¹Furnished with CRT Socket Cable.

Electrical Parts List-7623A/R7623A Service

Ckt No. Number	Tektronix	Serial/Model No.		Name & Description	Mfr Code	Mfr Part
	Part No.	Eff	Dscont			
R1418	315-0471-00			RES., FXD, CMPSN:470 OHM, 5%, 0.25W	01121	CB4715
R1419	315-0471-00			RES., FXD, CMPSN 470 OHM, 5%, 0.25W	01121	CB4715
R1421	315-0103-00			RES., FXD, CMPSN:IOK OHM, 5%, 0.25W	01121	CB1035
R1422	315-0103-00			RES., FXD, CMPSN:10K OHM, 5%, 0.25W	01121	CB1035
R1425	315-0103-00			RES., FXD, CMPSN:10K OHM, 5%, 0.25W	01121	CB1035
R1427	315-0474-00			RES., FXD, CMPSN:470K OHM, 5%, 0.25W	01121	CB4745
R1430	311-1404-00			RES., VAR, NONWIR:5K OHM X 5K OHM, 20%, W	01121	13M039
R1440	315-0223-00			RES., FXD, CMPSN:22K OHM, 5%, 0.25W	01121	CB2235
R1441	315-0362-00			RES., FXD, CMPSN3.6K OHM, 5%, 0.25W	01121	CB3625
R1443	315-0433-00			RES., FXD, CMPSN:43K OHM, 5%, 0.25W	01121	CB4335
R1445	315-0433-00			RES., FXD, CMPSN:43K OHM, 5%, 0.25W	01121	CB4335
R1447	315-0183-00			RES., FXD, CMPSN:18K OHM, 5%, 0.25W	01121	CB1835
R1448	315-0513-00			RES., FXD, CMPSN:51K OHM, 5%, 0.25W	01121	CB5135
R1452	323-0258-00			RES., FXD, FILM:4.75K OHM, 1%, 0.50W	91637	MFF1226G47500F
R1455	315-0202-00			RES., FXD, CMPSN:5K OHM, 5%, 0.25W	01121	CB2025
R1456	315-0202-00			RES., FXD, CMPSN:5K OHM, 5%, 0.25W	01121	CB2025
R1457	315-0752-00			RES., FXD, CMPSN:7.5K OHM, 5%, 0.25W	01121	CB7525
R1459	311-1227-00			RES.:VAR, NONWIR:5K OHM, 20%, 0.50W	80294	3389F-P31-502
R1461	321-0318-00			RES., FXD, FILM:20K OHM, 1%, 0.125W	75042	CEAT0-2002F
R1463	321-0812-07			RES., FXD, FILM:455 OHM, 0.1%, 0.125W	75 042	CEAT9-4550B
R1464	321-1068-07			RES., FXD, FILM:50.5 OHM, 0.1, 0.125W	75042	CEAT9-50R50B
R1466	321-0816-07			RES., FXD, FILM:5K OHM, 0.1%, 0.125W	75042	CEAT9-5001B
R1467	321-1068-07			RES., FXD, FILM:50.5 OHM, 0.1%, 0.125W	75042	CEAT9-50R50B
R1468	308-0679-00			RES., FXD, WW:0.51 OHM, 5%, 2W	75042	BWH-R5100
R472A, B	311-1581-00			RES., VAR, NONWIR:2 X 10K OHM, 10%	01121	11M753
R1474	315-0103-00			RES., FXD, CMPSN:100K OHM, 5%, 0.25W	01121	CB1035
R1476	315-0472-00			RES., FXD, CMPSN:4.7K OHM, 5%, 0.25W	01121	CB4725
R1478	315-0562-00			RES., FXD, CMPSN:5.6K OHM, 5%, 0.25W	01121	CB5625
R1483	315-0301-00			RES., FXD, CMPSN:300 OHM, 5%, 0.2W	01121	CB3015
R1486	321-0251-00			RES., FXD, FILM:4.02K OHM, 1%, 0.125W	75042	CEAT0-4021F
R1488A,B2	11-1581-00			RES., VAR, NONWIR:2X 10K OHM, 10%	01121	12M448
R1491	321-0010-00			RES., FXD, FILM:1.5K OHM, 1%, 0.25W	75042	CEAT0-1501F
R1493	315-0103-00			RES., FXD, CMPSN:10K OHM, 5%, 0.25W	01121	CB135
R102	315-0154-00			RES., FXD, CMPSN:150K OHM, 5%, 0.25W	01121	CB1545
R1510	315-0101-00			RES., FXD, CMPSN:100 OHM, 5%, 0.25W	01121	CB1015
R1511	315-0273-00			RES., FXD, CMPSN:27K OHM, 5%, 0.25W	01121	CB2735
R1513	315-0124-00			RES., FXD, CMPSN:120K OHM, 5%, 0.25W	01121	CB1245
RS115	315-0304-00	B010100	B129999	RES., FXD, CMPSN:300K OHM, 5, 0.25W	01121	CB3045
R1515	315-0123-00	B130000		RES., FXD, CMPSN:12K OHM, 5%, 0.25W	01121	CB1235
R1517	315-0155-00			RES., FXD, CMPSN:1.5 OHM, 5%, 0.25W	01121	CB1555
R1519	315-0300-00			RES., FXD, CMPSN:30 OHM, 5%, 0.2W	01121	CB3005
R1521	321-0263-00			RES., FXD, FILM:5.36K OHM, 1%, 0.125W	75042	CEAT0-5361F
R1522	321-0210-00			RES., FXD, FILM:1.5K OHM, 1%, 0.25W	75042	CEAT0-1501F
R1523	315-0271-00			RES., FXD, CMPSN:270 OHM, 5%, 0.25W	01121	CB2715
R1531	315-0564-00			RES., FXD, CMPSN:560K OHM, 5%, 0.25W	01121	CB5645
R1532	315-0223-00			RES., FXD, CMPSN:22K OHM, 5%, 0.25 W	01121	CB2235
R1534	315-0473-00			RES., FXD, CMPSN:47K OHM, 5%, 0.2W	01121	CB4735
R1536	315-0333-00			RES., FXD, CMPSN:33K OHM, 5%, 0.2W	01121	CB3335
R1537	315-0104-00			RES., FXD, CMPSN:100K OHM, 5%, 0.2W	01121	CB1045
R1539	315-0203-00			RES., FXD, CMPSN:20K OHM, 5%, 0.25W	01121	CB2035
R1541	315-0823-00			RES., FXD, CMPSN:82K OHM, 5%, .2 5W	01121	CB8235

¹Furnished as a unit with 51430.
²Furnished as a unit with S1488B, C.
 REV. C JULY. 1976

Electrical Parts List-7623A/R7623A Service

Ckt No.	Tektronix Part No.	Serial/Model No.		Name & Description	Mfr Code	Mfr Part
		Eff	Dscont			
R1542	315-0103-00			RES., FXD, CMPSN-10K OHM, 5%, 0.25W	01121	CB1035
R1544	321-0280-00			RES., FXD, FILM8.06K OHM, 1%, 0.125W	75042	CEATO-8061F
R1548	321-0280-00			RES., FXD, FILM:8.06K OHM, 1%, 0.125W	75042	CEATO-8061F
R1549	315-0361-00			RES., FXD, CMPSN-360 OHM, 5%, 0.25W	01121	CB3615
R1551	315-0103-00	B010100	B129999X	RES., FXD, CPSN:10K OHM, 5%, 0.25W	01121	CB1035
R1553	315-0682-00			RES., FXD, CMPSN:6.8K OHM, 5%, 0.25W	01121	CB6825
R1556	315-0361-00			RES., FXD, CMPSN:360 OHM, 5%, 0.25W	01121	CB3615
R1561	315-0103-00			RES., FXD, CMPSN: OK OHM, 5%, 0.25W	01121	CB1035
R1562	355-0103-00			RES., FXD, CMPSN 10K OHM, 5%, 0.25W	01121	CB1035
R1564	315-0472-00			RES., FXD, CMPSN:4.7K OHM, 5%, 0.25W	01121	CB4725
R1565	315-0472-00			RES., FXD, CHPSN4.7K OHM, 5%, 0.25W	01121	C84725
R1567	315-0103-00			RES., FXD, CMPSN10K OHM, 5%, 0.25W	01121	CB1035
R1571	315-0203-00			RES., FXD, CMPSN 20K OHM, 5%, 0.25W	01121	CB2035
R1572	315-0203-00			RES., FXD, CMPSSO20K OHM, 5%, 0.25W	01121	CB2035
R1573	315-0203-00			RES., FXD, CMPSN:20K OHM, 5%, 0.25W	01121	CB2035
R1574	315-0472-00			RES., FXD, CMPSN:4.7K OHM, 5%, 0.25W	01121	CB4725
R1576	315-0332-00			RES., FXD, CMPSN:3 3K OHM, 5%, 0.25W	01121	CB3325
R1579	315-0471-00			RES., FXD, CMPSN:470 OHM, 5%, 0.25W	01121	CB4715
R1580	315-0152-00			RES., FXD, CMPSN:1.K OHM, 5%, 0.25W	01121	CB1525
R1582	315-0202-00			RES., FXD, CMPSN:2K OHM, 5%, 0.25W	01121	CB2025
R1584	315-0203-00			RES., FXD, CMPSN:20K OHM, 5%, 0.25W	01121	CB2035
R1589	315-0102-00			RES., FXD, CMPSN:1K OHM, 5%, 0.25W	01121	CB1025
R1591	315-0752-00			RES., FXD, CMPSN:7.5K OHM, 5%, 0.25W	01121	CB7525
R1592	315-0752-00			RES., FXD, CMPSN:7.5K OHM, 5%, 0.25W	01121	CB7525
R1593	315-0752-00			RES., FXD, CMPSN:7.5K OHM, 5%, 0.25W	01121	CB7525
R1595	315-0103-00			RES., FXD, CMPSN:10K OHM, 5%, 0.25W	01121	CB1035
R1597	315-0241-00			RES., FXD, CMPSN:240 OHM, 5%, 0.25W	01121	CB2415
R1599	315-0472-00	B010100	B129999	RES., FXD, CMPSN:4.7K OHM, 5%, 0.25W	01121	CB4725
R1599	315-0822-00	B130000		RES., FXD, CMPSN:8.2K OHM, 5%, 0.25W	01121	CB8225
R1601	321-0365-00			RES., FXD, FILM:61.9K OHM, 1%, 0.125W	75042	CEATO-6192F
R1603	315-0751-00			RES., FXD, CMPSN:750 OHM, 5%, 0.25W	01121	CB7515
R1606	315-0471-00			RES., FXD, CMPSN:470 OHM, 5%, 0.25W	01121	CB4715
R1608	321-0330-00			RES., FXD, FILM:26.7K OHM, 1%, 0.125W	75042	CEATO-2672F
R1611	321-0280-00			RES., FXD, FILM:8.06K OHM, 1%, 0.125W	75042	CEATO-8061F
R1614	321-0273-00	B010100	B129999	RES., FXD, FILM:6.81K OHM, 1%, 0.125W	75042	CEATO-6811F
R1614	321-0268-00	B130000		RES., FXD, FILM:6.04K OHM, 1%, 0.125W	75042	CEATO-6041F
R1617	321-0248-00	B010100	B129999X	RES., FXD, FILM:3.74K OHM, 1%, 0.125W	75042	CEATO-3741F
R1620	315-0683-00			RES., FXD, CMPSN:68K OHM, 5%, 0.25W	01121	CB6835
R1621	315-0183-00			RES., FXD, CMPSN:18K OHM, 5%, 0.25W	01121	CB1835
R1622	315-0471-00			RES., FXD, CMPSN:470 OHM, 5%, 0.25W	01121	CB4715
R1626	315-0472-00	B010100	B129999X	RES., FXD, CMPSN:4.7K OHM, 5%, 0.25W	01121	CB4725
R1627	315-0303-00	B10100	B129999X	RES., FXD, CMPSN:30K OHM, 5%, 0.25W	01121	CB3035
R1629	315-0242-00			RES., FXD, CMPSN:2.4K OHM, 5%, 0.25W	01121	CB2425
R1631	315-0151-00			RES., FXD, CMPSN:150 OHM, 5%, 0.25W	01121	CB1515
R1633	315-0394-00			RES., FXD, CMPSN:390K OHM, 5%, 0.25W	01121	CB3945
R1635	315-0202-00			RES., FXD, CMPSN:2K OHM, 5%, 0.25W	01121	CB2025
R1637	321-0425-00			RES., FXD, FILM:261K OHM, 1%, 0.125W	75042	CEATO-2613F
R1639	321-0452-00			RES., FXD, FILM:499K OHM, 1%, 0.125W	75042	CEATO-4993F
R1641	315-0203-00			RES., FXD, CMPSN:20K OHM, 5%, 0.25W	01121	CB2035
R1642	315-0203-00			RES., FXD, CMPSN:20K OHM, 5%, 0.25W	01121	CB2035
R1644	321-0277-00			RES., FXD, FILM:7.5K OHM, 1%, 0.125W	75042	CEATO-7501F
R1646	311-1235-00			RES., VAR, NONWIR:100K OHM, 20%, 0.50W	80294	3386F-T04-104
R1647	321-0306-00	B010100	B129999	RES., FXD, FILM:15K OHM, 1%, 0.125W	75042	CEATO-1502ZF
R1647	321-0402-00	B130000		RES., FXD, FILM:150K OHM, 1%, 0.125W	75042	CEATO-1503F
R1648	315-0104-00			RES., FXD, CMPSN:100K OHM, 5%, 0.25W	01121	CB1045
R1649	315-0203-00			RES., FXD, CMPSN:20K OHM, 5%, 0.25W	01121	CB2035

REV. E AUG. 1977

Electrical Parts List-7623A/R7623A Service

Ckt No.	Tektronix Part No.	Serial/Model No. Eff	Dscont	Name & Description	Mfr Code	Mfr Part
R1650	315-0203-00			RES., FXD, CMPSN:20K OHM, 5, 0.25W	01121	CB2035
R1651	315-0154-00	XB130000	B139999	RES., FXD, CMPSN:150K OHM, 5%, 0.25W	01121	CB1545
R1651	315-0304-00	B140000		RES., FXD, CMPSN:300K OHM, 5%, 0.25W	01121	CB3045
R1653	321-0385-00			RES., FXD, FILM:100K OHM, 1%, 0.125W	91637	MFF1816G10002F
R1654	321-0414-00	B010100	B159999	RES., FXD, FILM:200K OHM, 1%, 0.125W	91637	MFF1816G20002F
R1654	321-0416-00	B160000		RES., FXD, FILM:21K OHM, 1%, 0.125W	91637	MFF1816G21002F
R1656	321-0375-00			RES., FXD, FILM:78.7K OHM, 1%, 0.125W	91637	MFF1816G78701F
R1658	311-1231-00			RES., VAR, NONWIR: 25K OHM, 20%, 0.50W	32997	3386F-T04-253
R1660	321-0320-00			RES., FXD, FILM:21K OHM, 1%, 0.125W	91637	MFF1816G21001F
R1661	315-0433-00			RES., FXD, CMPSN:43K OHM, 5%, 0.25W	01121	CB4335
R1662	315-0392-00			RES., FXD, CMPSN:3.9K OHM, 5%, 0.25W	01121	CB3925
R1663	315-0472-00			RES., FXD, CMPSN:4.7K OHM, 5%, 0.25W	01121	CB4725
R1665	315-0222-00			RES., FXD, CMPSN:2.2K OHM, 5%, 0.25W	01121	CB2225
R1666	315-0332-00			RES., FXD, CMPSN:3.3K OHM, 5%, 0.25W	01121	CB3325
R1668	315-0472-00			RES., FXD, CMPSN:4.7K OHM, 5%, 0.25W	01121	CB4725
R1671	315-0203-00			RES., FXD, CMPSN:10K OHM, 5%, 0.25W	01121	CB1035
R1672	315-0683-00			RES., FXD, CMPSN:68K OHM, 5%, 0.25W	01121	CB6835
R1675	321-0356-00			RES., FXD, FILM:49.9K OHM, 1%, 0.125W	91637	MFF1816G49901F
R1677	311-1232-00			RES., VAR, NONIR:50K OHM, 20%, 0.50W	32997	3386F-T04-503
R1678	321-0364-00	B000100	B129999X	RES., FXD, FILM:60.4K OHM, 1%, 0.125W	91637	MFF1816G60401F
R1679	321-0402-00			RES., FXD, FILM:150K OHM, 1%, 0.125W	91637	MFF1816G15002F
R1681	315-0333-00			RES., FXD, CMPSN:33K OHM, 5%, 0.25W	01121	CB3335
R1682	315-0103-00			RES., FXD, CMPSN:OK OHM, 5%, 0.25W	01121	CB1035
R1683	315-0224-00			RES., FXD, CMPSN:220K OHM, 5%, 0.25W	01121	CB2245
R1685	321-0414-00			RES., FXD, FILM:200K OHM, 1%, 0.125W	91637	MFF1816G20002F
R1687	321-0349-00	B010100	B159999	RES., FXD, FILM:42.2K OHM, 1%, 0.125W	91637	MFF1816G42201F
R1687	321-0339-00	B160000		RES., FXD, FILM:33.2K OHM, 1%, 0.125W	91637	MFF1816G33201F
R1689	311-1231-00			RES., VAR, NONWIR:25K OHM, 20%, 0.50W	32997	3386F-T04-253
R1690	321-0378-00			RES., FXD, FILM:84.5K OHM, 1%, 0.125W	91637	MFF1816GB4501F
R1693	315-0302-00			RES., FXD, CMPSN:3K OHM, 5%, 0.25W	01121	CB3025
R1694	315-0204-00			RES., FXD, CMPSN:200K OHM, 5%, 0.25W	01121	CB2045
R169	315-0154-00			RES., FXD, CMPSN:150K OHM, 5%, 0.25W	01121	CB1545
R1698	315-0202-00			RES., FXD, CMPSN:2K OHM, 5%, 0.25W	01121	CB2025
R1699	315-0202-00			RES., FXD, CMPSN:2K OHM, 5%, 0.25W	01121	CB2025
R1701	315-0153-00	B010100	B159999	RES., FXD, CMPSN:15K OHM, 5%, 0.25W	01121	CB1535
R1701	315-0912-00	B160000		RES., FXD, CMPSN:9.1K OHM, 5%, 0.25W	01121	CB9125
R1704	315-0391-00			RES., FXD, CMPSN:390 OHM, 5%, 0.25W	01121	CB3915
R1705	315-0163-00	B010100	B159999	RES., FXD, CMPSN:16K OHM, 5%, 0.25W	01121	CB1635
R1705	315-0113-00	B160000		RES., FXD, CMPSN:11K OHM, 5%, 0.25W	01121	CB1135
R1707	315-0221-00			RES., FXD, CMPSN:220 OHM, 5%, 0.25W	01121	CB2215
R1709	315-0154-00			RES., FXD, CMPSN:150K OHM, 5%, 0.25W	01121	CB1545
R1711	315-0102-00			RES., FXD, CMPSN:1K OHM, 5%, 0.25W	01121	CB1025
R1713	321-0414-00			RES., FXD, FILM:200K OHM, 1%, 0.125W	91637	MFF1816G20002F
R1716	315-0332-00			RES., FXD, CMPSN:3.3K OHM, 5%, 0.25W	01121	CB3325
R1717	315-0332-00			RES., FXD, CMPSN:3.3K OHM, 5%, 0.25W	01121	CB3325
R1719	315-0154-00			RES., FXD, CMPSN:150K OHM, 5%, 0.25W	01121	CB1545
R1721	315-0683-00			RES., FXD, CMPSN:68K OHM, 5%, 0.25W	01121	CB6835
R1723	301-0753-00			RES., FXD, CMPSN:75K OHM, 5%, 0.50W	01121	EB7535
R1725	315-0472-00			RES., FXD, CMPSN:4.7K OHM, 5%, 0.25W	01121	CB4725
R1726	315-0433-00			RES., FXD, CMPSN:43K OHM, 5%, 0.2W	01121	CB4335
R1730	315-0335-00			RES., FXD, CMPSN:3.3 OHM, 5%, 0.2W	01121	CB3355
R1731	315-0335-00			RES., FXD, CMPSN:3.3 OHM, 5%, 0.25W	01121	CB3355
R1733	301-0753-00			RES., FXD, CMPSN:75K OHM, 5%, 0.50W	01121	EB7535
R1737	315-0334-00			RES., FXD, CMPSN:330K OHM, 5%, 0.25W	01121	CB3345
R1739	315-0125-00			RES., FXD, CMPSN:1.2M OHM, 5%, 0.25W	01121	CB1255
R1741	315-0155-00			RES., FXD, CMPSN:1.5M OHM, 5%, 0.25W	01121	CB1555
R1742	301-0305-00			RES., FXD, CMPSN:3M OHM, 5%, 0.50W	01121	EB3055
R1750	311-1584-00	B010100	B129999	RES., VAR, NONWIR:50K OHM, 10%, 0.50W	12697	382CM40221
R1750	311-1271-00	B130000		RES., VAR, NONWIR:50K OHM, 10%, 0.50W	32997	3329P-L58-S03
R1752	321-0354-00			RES., FXD, FILM:47.5K OH., 1%, 0.125W	91637	PF1816C4750Sr

REV. E AUG. 1977

Electrical Parts List-7623A/R7623A Service

Ckt No. Number	Tektronix Part No.	Serial/Model No.		Name & Description	Mfr Code	Mfr Part
		Eff	Dscont			
R1754	311-1232-00			RES., VAR, NONWIR:50K OHM, 20%, 0.50W	80294	3389F-P31-503
R1756	321-0356-00			RES., FXD, FILM:49.9K OHM, 1%, 0.125W	75042	CEATO-4992F
R1758	321-0289-00			RES., FXD, FILM:10K OHM, 1%, 0.125W	75042	CEATO-1002F
R1759	321-0335-00			RES., FXD, FILM:30.1K OHM, 1%, 0.125W	75042	CEATO-3012F
R1762	315-0203-00			RES., FXD, CMPSN:20K OHM, 5%, 0.25W	01121	CB2035
R1764	321-0452-00			RES., FXD, FILM:499K OHM, 1%, 0.125W	75042	CEATO-4993F
R1766	321-0414-00			RES., FXD, FILM:200K OHM, 1%, 0.125W	75042	CEATO-2003F
R1768	321-0280-00			RES., FXD, FILM:8.06K OHM, 1%, 0.125W	75042	CEATO-8061F
R1769	321-0354-00			RES., FXD, FILM:47.5K OHM, 1%, 0.25W	75042	CEATO-4752F
R1770	321-0346-00			RES., FXD, FILM:39.2K OHM, 1%, 0.125W	75042	CEATO-3922F
R1773	321-0193-00			RES., FXD, FILM:K OHM, 1%, 0.125W	75042	CEATO-1001F
R1774	321-0300-00			RES., FXD, FILM:13K OHM, 1%, 0.125W	75042	CEATO-130 2F
R1777	321-0306-00			RES., FXD, FILM:15K OHM, 1%, 0.125W	75042	CEATO-1502F
R1779	311-1225-00			RES., VAR, NONWIR:1K OHM, 20%, 0.50W	80294	3389F-P31-102
R1781	321-0306-00			RES., FXD, FILM:15K OHM, 1%, 0.125W	75042	CEATO-1502F
R1783	311-1228-00			RES., VAR, NONWIR:10K OHM, 20%, 0.50W	80294	3389F-P31-103
R1785	321-0323-00			RES., FXD, FILM:22.6K OHM, 1%, 0.125W	75042	CEATO-2262F
R1787	315-0222-00			RES., FXD, CMPSN:2.2K OHM, 5%, 0.25W	01121	CB2225
R1788	315-0752-00			RES., FXD, CMPSN:7.5K OHM, 5%, 0.25W	01121	CB7525
R1791	315-0822-00			RES., FXD, CMPSN:8.2K OHM, 5%, 0.25W	01121	CB8225
R1792	322-0385-00			RES., FD, FILM:100K OHM, 1%, 0.25W	75042	CEBTO-1003F
R1793	315-0201-00			RES., FXD, CMPSN:200 OHM, 5%, 0.2W	01121	CB2015
R1795	315-0103-00			RES., FXD, CMPSN:10K OHM, 5%, 0.25W	01121	CB1035
R1796	315-0203-00			RES., FXD, CMPSN:20K OHM, 5%, 0.25W	01121	CB2035
R1798	315-0102-00			RES., FXD, CMPSN:1K OHM, 5%, 0.25W	01121	CB1025
R1799	315-0471-00			RES., FXD, CMPSN:470 OHM, 5%, 0.25W	01121	CB4715
R8018	315-0153-00	B010100	B129999X	RES., FXD, CMPSN:15K OHM, 5%, 0.25W	01121	CB1535
R1802	315-0153-00			RES., FXD, CMPSN:15K OHM, 5%, 0.25W	01121	CB1535
R1803	315-0153-00			RES., FXD, CMPSN:15K OHM, 5%, 0.25W	01121	CB1535
R1806	321-0382-00			RES., FXD, FILM:93.1K OHM, 1%, 0.125W	75042	CEATO-9312F
R1808	315-0203-00			RES., FXD, CMPSN:20K OHM, 5%, 0.25W	01121	CB2035
R1809	315-0623-00			RES., FXD, CMPSN:62K OHM, 5%, 0.25W	01121	CB6235
R1811	321-0337-00			RES., FXD, FILM:31.6K OHM, 1%, 0.125W	75042	CEATO-3162F
R1812	321-0424-00			RES., FXD, FILM:255K OHM, 1%, 0.125W	75042	CEATO-2553F
R1814	315-0304-00			RES., FXD, CMPSN:300K OHM, 5%, 0.25W	01121	CB3045
R1817	315-0333-00			RES., FXD, CMPSN:33K OHM, 5%, 0.25W	01121	CB3335
R1818	315-0103-00			RES., FXD, CMPSN:10K OHM, 5%, 0.25W	01121	CB1035
R1819	315-0103-00			RES., FXD, CMPSN:10K OHM, 5%, 0.25W	01121	CB1035
R1820	315-0104-00			RES., FXD, CMPSN:100K OHM, 5%, 0.25W	01121	CB1045
R1822	321-0457-00			RES., FXD, FILM:562K OHM, 1%, 0.125W	91637	MFF1816G56202F
R1823	321-0382-00			RES., FXD, FILM:93.1K OHM, 1%, 0.125W	75042	CEATO-9312F
R1826	315-0223-00			RES., FXD, CMPSN:22K OHM, 5%, 0.25W	01121	CB2235
R1829	315-0471-00			RES., FXD, CMPSN:470 OHM, 5%, 0.25W	01121	CB4715
R1830	315-0753-00			RES., FXD, CMPSN:75K OHM, 5%, 0.25W	01121	CB7535
R1832	303-0823-00			RES., FXD, CMPSN:82K OHM, 5%, 1W	01121	GB8235
R1833	303-0823-00			RES., FXD, CMPSN:82K OHM, 5%, 1W	01121	GB88235
R1835	315-0471-00			RES., FXD, CMPSN:470 OHM, 5%, 0.25W	01121	CB4715
R1838	321-0423-00			RES., FXD, FILM:249K OHM, 1%, 0.125W	75042	CEATO-2493F
R1840	315-0203-00			RES., FXD, CMPSN:20K OHM, 5%, 0.25W	01121	CB2035
R1841	315-0623-00			RES., FXD, CMPSN:62K OHM, 5%, 0.25W	01121	CB6235
R1842	315-0203-00			RES., FXD, CMPSN:20K OHM, 5%, 0.25W	01121	CB2035
R1844	315-0203-00			RES., FXD, CMPSN:20K OHM, 5%, 0.25W	01121	CB2035
R1847	321-0297-00			RES., FXD, FILM:12.1K OHM, 1%, 0.125W	75042	CEATO-1212F

REV. C JUL. 1976

Electrical Parts List-7623A/R7623A Service

Ckt No. Number	Tektronix		Serial/Model No.		Name & Description	Mfr Code	Mfr Part
	Part No.	Eff	Dscont				
R1849	321-0406-00			RES., FXD, FILM:165K OHM, 1%, 0.125W	75042	CEATO-1653F	
R1851	315-0103-00			RES., FXD, CMPSN:10K OHM, 5%, 0.25W	01121	CB1035	
R1852	315-0103-00			RES., FXD, CMPSN:10K OHM, 5%, 0.25W	01121	CB1035	
R1855	315-0104-00			RES., FXD, CMPSN:100K OHM, 5%, 0.25W	01121	CB1045	
R1856	321-0466-00			RES., FXD, FILM:698K OHM, 1%, 0.125W	75042	CEATO-6983	
R1857	321-0379-00			RES., FXD, FILM:86.6K OHM, 1%, 0.125W	75042	CEATO-8662F	
R1859	315-0104-00			RES., FXD, CMPSN:100K OHM, 5%, 0.25W	01121	CB1045	
R1862	301-0393-00			RES., FXD, CMPSN:39K OHM, 5%, 0.25W	01121	EB3935	
R1863	321-0452-00			RES., FXD, FILM:499K OHM, 1%, 0.125W	75042	CEATO-4993F	
R1865	321-0352-00			RES., FXD, FILM:45.3K OHM, 1%, 0.125W	75042	CEATO-4532F	
R1866	321-0358-00			RES., FXD, FILM:52.3K OHM, 1%, 0.125W	75042	CEATO-5232F	
R1867	321-0385-00			RES., FXD, FILM:100K OHM, 1%, 0.125W	75042	CEATO-1003F	
R1869	315-0222-00			RES., FXD, CMPSN:2.2K OHM, 5%, 0.25W	01121	CB2225	
R1871	321-0444-00			RES., FXD, FILM:412K OHM, 1%, 0.125W	75042	CEATO-4123F	
R1873	321-0445-00			RES., FXD, FILM:422K OHM, 1%, 0.125W	75042	CEATO-4223F	
R1875	321-0409-00			RES., FXD, FILM:178K OHM, 1%, 0.125W	75042	CEATO-1783F	
R1876	321-0379-00			RES., FXD, FILM:86.6K OHM, 1%, 0.125W	75042	CEATO-8662F	
R1878	321-0411-00			RES., FXD, FILM:187K OHM, 1%, 0.12W	75042	CEATO-1873F	
R1880	315-0104-00			RES., FXD, CMPSN:100K OHM, 5%, 0.25W	01121	CB1045	
R1883	315-0393-00			RES., FXD, CMPSN:39K OHM, 5%, .25W	01121	CB3935	
R1885	321-0452-00			RES., FXD, FILM:499K OHM, 1%, 0.125W	75042	CEATO-4993F	
R1886	315-0222-00			RES., FXD, CMPSN:2.2K OHM, 5%, 0.25W	01121	CB2225	
R189	321-0449-00			RES., FXD, FILM:464K OHM, 1%, 0.125W	75042	CEATO-4643F	
R1892	315-0392-00			RES., FXD, CMPSN:3.9K OHM, 5%, 0.25W	01121	CB3925	
R1893	315-0392-00			RES., FXD, CMPSN:3.9K OHM, 5%, 0.25W	01121	CB3925	
R1895	315-0393-00			RES., FXD, CMPSN:39K OHM, 5%, 0.25W	01121	CB3935	
R1897	321-0397-00			RES., FXD, FILM:133K OHM, 1%, 0.125W	75042	CEATO-1333F	
R1900	321-0400-00			RES., FXD, FILM:143K OHM, 1%, 0.125W	75042	CEATO-1433F	
Re903	315-0824-00			RES., FXD, CMPSN:820K OHM, 5%, 0.25W	01121	CB8245	
R1906	301-0363-00			RES., FXD, CMPSN:36K OHM, 5%, 0.50 W	01121	EB3635	
R1908	321-0452-00			RES., FXD, FILM:499K OHM, 1%, 0.125W	75042	CEATO-4993F	
R1910	315-0102-00			RES., FXD, CMPSN:1K OHM, 5%, 0.25 W	01121	CB102	
R1911 ¹							
R1912	315-0102-00			RES., FXD, CMPSN:1K OHM, 5%, 0.25W	01121	CB1025	
R1917	315-0472-00			RES., FXD, CMPSN:4.7K OHM, 5%, 0.25W	01121	CB4725	
R1919	315-0472-00			RES., FXD, CMPSN:4.7K OHM, 5%, 0.25W	01121	CB4725	
R1920	315-0472-00			RES., FXD, CMPSN:4.7K OHM, 5%, 0.25W	01121	CB4725	
R1922	315-0105-00			RES., FXD, CMPSN:1M OHM, 5%, 0.25W	01121	CB1055	
R1923	315-0473-00			RES., FXD, CMPSN:47K OHM, 5%, 0.25W	01121	CB4735	
R1924	315-0912-00			RES., FXD, CMPSN:9.1K OHM, 5%, 0.25W	01121	CB9125	
R1925	315-0302-00			RES., FXD, CMPSN:3K OHM, 5%, 0.25W	01121	CB3025	
R1926	315-0911-00			RES., FXD, CMPSN:910 OHM, 5%, 0.25W	01121	CB9115	
R1928	315-0823-00			RES., FXD, CMPSN:82K OHM, 5%, 0.25W	01121	CB8235	
R1929 ¹							
R1930	308-0290-00			RES., FXD, WW:8 OHM, 5%, 5W	91637	RS2AD8R000J	
R1942	301-0564-00			RES., FXD, CMPSN:560K OHM, 5%, 0.50W	01121	EB5645	
R1981	307-0106-00			RES., FXD, CMPSN:4.7 OHM, 5%, 0.25W	01121	CB47G5	
R1983	307-0103-00			RES., FXD, CMPSN:2.7 OHM, 5%, 0.25W	01121	CB27G5	
R1987	307-0103-00			RES., FXD, CMPSN:2.7 OHM, 5%, 0.25W	01121	CB27G	
R1989	315-0100-00			RES., FXD, CMPSN:10 OHM, 5, 0.25W	01121	CB10005	
R2101	315-0682-00			RES., FXD, CMPSN:6.K OHM, 5%, 0.25W	01121	CB6825	
R2102	315-0103-00			RES., FXD, CMPSN:10K OHM, 5%, 0.25W	01121	CB1035	
R2104	315-0333-00			RES., FXD, CMPSN:33K OHM, 5%, 0.25W	01121	CB3335	

¹Furnished with CRT Socket Cable.

Electrical Parts List-7623A/R7623A Service

Ckt No. Number	Tektronix	Serial/Model No.		Name & Description	Mfr	Mfr Part
	Part No.	Eff	Dscont		Code	
R2105	315-0153-00			RES., FXD, CMPSN:15K OHM, 5%, 0.25W	01121	CB1535
R2107	315-0510-00			RES., FXD, CMPSN:51 OHM, 5%, 0.25W	01121	CB5105
R2108	315-0512-00			RES., FXD, CMPSN:5.1K OHM, 5, 0.25W	01121	CB5125
R2110	315-0221-00			RES., FXD, CMPSN:220 OHM, 5%, 0.25W	01121	CB2215
R2112	315-0102-00			RES., FXD, CMPSN:1K OHM, 5%, 0.25W	01121	CB1025
R2113	315-0301-00			RES., FXD, CMPSN:300 OHM, 5%, 0.2W	01121	CB3015
R2122	315-0432-00			RES., FXD, CMPSN:4.3K OHM, 5%, 0.25W	01121	CB4325
R2123	315-0683-00			RES., FXD, CMPSN:68K OHM, 5%, 0.25W	01121	CB6835
R2127	315-0302-00			RES., FXD, CMPSN:3K OHM, 5%, 0.25W	01121	CB3025
R2128	311-1263-00			RES., VAR, NONWIR:1K OHM, 10%, 0.50W	73138	62PT-347-0
R2129	315-0183-00			RES., FXD, CMPSN:8K OHM, 5%, 0.25W	01121	CB1835
R2135	315-0393-00			RES., FXD, CMPSN:39K OHM, 5%, 0.25W	01121	CB3935
R2137	315-0752-00			RES., FXD, CMPSN:7.5K OHM, 5%, 0.25W	01121	CB7525
R2139	315-0242-00			RES., FXD, CMPSN:2.4K OHM, 5%, 0.25W	01121	CB2425
R2144	315-0104-00			RES., FXD, CMPSN:100K OHM, 5%, 0.25W	01121	CB1045
R2146	315-0152-00			RES., FXD, CMPSN:1.5K OHM, 5%, 0.25W	01121	CB1525
R2148	315-0103-00			RES., FXD, CMPSN:10K OHM, 5%, 0.25W	01121	CB1035
R2150	321-0403-00			RES., FXD, FILM:154K OHM, 1%, 0.125W	75042	CEAT0-1543F
R2151	321-0372-00			RES., FXD, FILM:73.2K OHM, 1%, 0.125W	75042	CEAT0-7322F
R2153	315-0103-00			RES., FXD, CMPSN:1K OHM, 5%, 0.25W	01121	CB1035
R2155	315-0512-00			RES., FXD, CMPSN:5.1K OH, 5%, 0.25W	01121	CB5125
R2158	315-0152-00			RES., FXD, CMPSN:5K OHM, 5%, 0.25W	01121	CB1525
R2161	315-0102-00			RES., FXD, CMPSN:1K OHM, 5%, 0.25W	01121	CB1025
R2162	315-0751-00			RES., FXD, CMPSN:750 OHM, 5%, 0.25W	01121	CB7515
R2163	315-0751-00			RES., FXD, CMPSN:750 OHM, 5%, 0.25W	01121	CB7515
R2165	315-0102-00			RES., FXD, CMPSN:1K OHM, 5%, 0.25W	01121	CB1025
R2166	315-0751-00			RES., FXD, CMPSN:750 OHM, 5%, 0.25W	01121	CB7515
R2167	315-0751-00			RES., FXD, CMPSN:750 OHM, 5%, 0.25W	01121	CB7515
R2169	315-0102-00			RES., FXD, CMPSN:1K OHM, 5%, 0.25W	01121	CB1025
R2170	315-0751-00			RES., FXD, CMPSN:750 OHM, 5%, 0.25W	01121	CB7515
R2171	315-0751-00			RES., FXD, CMPSN 750 OHM, 5%, 0.25W	01121	CB7515
R2173	315-0102-00			RES., FXD, CMPSN:1K OHM, 5%, 0.25W	01121	CB1025
R2174	315-0751-00			RES., FXD, CMPSN:750 OHM, 5%, 0.25W	01121	CB7515
R2175	315-0751-00			RES., FXD, CMPSN:750 OHM, 5%, 0.25W	01121	CB7515
R2177	315-0511-00			RES., FXD, CMPSN:510 OHM, 5%, 0.25W	01121	CB5115
R2178	315-0511-00			RES., FXD, CMPSN:510 OHM, 5%, 0.25W	01121	CB5115
R2179	315-0511-00			RES., FXD, CMPSN:510 OHM, 5%, 0.25W	01121	C85115
R2182	321-0262-00			RES., FXD, FILM:5.23K OHM, 1%, 0.125W	75042	CEAT0-231F
R2183	311-1224-00			RES., VAR, NONWIR:500 OHM, 20%, 0.50W	80294	3389F-P31-501
R2191	315-0513-00			RES., FXD, CMPSN:51K OHM, 5%, 0.25W	01121	CB5135
R2192	315-0133-00			RES., FXD, CMPSN:13K OHM, 5%, 0.25W	01121	CB1335
R2193	315-0133-00			RES., FXD, CMPSN:13K OHM, 5%, 0.25W	01121	CB1335
R2194	315-0753-00			RES., FXD, CMPSN:75K OHM, 5%, 0.25W	01121	CB7535
R2196	321-0308-00			RES., FXD, FILM:15.8K OHM, 1%, 0.125W	75042	CEAT0-1582F
R2197	315-0513-00			RES., FXD, CMPSN:51K OHM, 5%, 0.25W	01121	CB5135
R2198	321-0319-00			RES., FXD, FILM:20.5K OHM, 1%, 0.125W	75042	CEAT0-2052F
R2199	321-0335-00			RES., FXD, FILM:30.1K OHM, 1%, 0.125W	75042	CEAT0-3012F
R2201	315-0154-00			RES., FXD, CMPSN:150K OHM, 5%, 0.25W	01121	CB1545
R2202	321-0335-00			RES., FXD, FILM:30.1K OHM, 1%, 0.125W	75042	CEAT0-3012F
R2203	321-0344-00			RES., FXD, FILM:37.4K OHM, 1%, 0.125W	75042	CEAT0-3742F
R2204	321-0335-00			RES., FXD, FILM:30.1K OHM, 1%, 0.125W	75042	CEAT0-3012F
R2206	315-0513-00			RES., FXD, CMPSN:51K OHM, 5%, 0.25W	01121	CB5135
R2207	315-0154-00			RES., FXD, CMPSN:150K OHM, 5%, 0.25W	01121	CB1545

REV. C JAN. 1975

Electrical Parts List-7623A/R7623A Service

Ckt No. Number	Tektronix		Serial/Model No.		Name & Description	Mfr Code	Mfr Part
	Part No.	Eff	Dscont				
R2208	321-0335-00				RES., FXD, FILM:30.K OHM, 1%, 0.125W	75042	CEAT0-3012F
R2209	321-0335-00				RES., FXD, FILM:30.K OHM, 1%, 0.125W	75042	CEAT0-3012F
R2211	315-0752-00				RES., FXD, CMPSN:7.5K OHM, 5%, 0.25 W	01121	CB7525
R2213	321-0259-00				RES., FXD, FILM:4.87K OHM, 1%, 0.125W	12697	MFFP1816G48700F
R2214	311-1224-00				RES., VAR, NONWIR:500 OHM, 20%, .50W	80294	3389F-P31-501
R2215	315-0133-00				RES., FXD, CMPSN:13K OHM, 5%, 0.25W	01121	CB1335
R2217	315-0124-00				RES., FXD, CMPSN:120K OHM, 5%, 0.25W	01121	CB1245
R2219	315-0751-00				RES., FXD, CMPSN:750 OHM, 5%, 0.25W	01121	CB7515
R2220	321-0299-00				RES., FXD, FILM:12.7K OHM, 1%, 0.125W	75042	CEAT0-1272F
R2221	321-0212-00				RES., FXD, FILM:58K OHM, 1%, 0.125W	75042	CEAT0-1581F
R2226	315-0222-00				RES., FXD, CMPSN:2.2K OHM, 5%, 0.25W	01121	CB2225
R2227	321-0268-00				RES., FXD, FILM:6.04K OHM, 1%, 0.125W	75042	CEAT0-6041F
R2229	321-0210-00				RES., FXD, FILM:1.5K OHM, 1%, .125W	75042	CEAT0-1501F
R2231	315-0303-00				RES., FXD, CMPSN:30K OHM, 5%, 0.25W	01121	CB3035
R2235	315-0203-00				RES., FXD, CMPSN:20K OHM, 5%, 0.25W	01121	CB2035
R2236	315-0203-00				RES., FXD, CMPSN:20K OHM, 5%, 0.25W	01121	CB035
R2237	315-0203-00				RES., FXD, CMPSN:20K OM, 5%, 0.25W	01121	CB2035
R2238	315-0203-00				RES., FXD, CMPSN:20K OHM, 5%, 0.25W	01121	CB2035
R2241	321-0326-00				RES., FXD, FILM:24.3K OHM, 1%, 0.125W	75042	CEAT0-2432F
R2251	315-0102-00				RES., FXD, CMPSN:1K OHM, 5%, 0.25W	01121	CB1025
R2252	315-0102-00				RES., FXD, CMPSN:1K OHM, 5%, 0.25W	01121	CB1025
R2253	315-0102-00				RES., FXD, CMPSN:1K OHM, 5%, 0.25W	01121	CB1025
R2254	315-0303-00				RES., FXD, CMPSN:30K ORM, 5%, 0.25W	01121	CB3035
R2261	315-0272-00				RES., FXD, CMPSN:2.7K OHM, 5%, 0.25W	01121	CB2725
R2262	315-0102-00				RES., FXD, CMPSN:1K OHM, 5%, 0.25 W	01121	CB1025
R2265	315-0512-00				RES., FXD, CMPSN:5.1K OHM, 5%, 0.25W	01121	SB5125
R2266	315-0912-00				RES., FXD, CMPSN:9.1K OHM, 5%, 0.25W	01121	CB9125
R2268	321-0296-00				RES., FXD, FILM:11.8K OHM, 1%, 0.125W	75042	CEAT0-1182ZF
R2273	311-1226-00				RES., VAR, NONWIR:2.5K OHM, 20%, 0.50W	80294	3389F-P31-252
R2274	321-0153-00				RES., FXD, FILM:383 OHM1, 1%, .125W	75042	CEAT0-3830F
R2275	321-0170-00				RES., FXD, FIM:576 OHM, 1%, 0.125W	75042	CEAT0-5760F
R2276	315-0223-00				RES., FXD, CMPSN:22K OHM, 5%, 0.25W	01121	CB2235
R2277	321-0250-00				RES., FXD, FILM:3.92K OHM, 1%, 0.125W	75042	CEAT0-3921F
R2278	315-0823-00				RES., FXD, CMPSN:82K OM, 5%, 0.25W	01121	CB8235
R2279	321-0222-00				RES., FXD, FILM:2K ORM, 1%, 0.125W	75042	CEAT0-2001F
R2280	315-0823-00				RES., FXD, CMPSN:82K OHM, 5%, 0.25 W	01121	CB8235
R2281	315-0101-00			XB030270	RES., FXD, CMPSN:100 OHM, 5%, .25W	01121	CB1015
R2282	315-0332-00				RES., FXD, CMPSN:3.3K OHM, 5%, 0.25W	01121	CB3325
R2283	315-0753-00				RES., FXD, CMPSN:75K OHM, 5%, 0.25W	01121	CB7535
R2284	321-0216-00				RES., FXD, FILM:1.74K OHM, 1%, 0.125W	75042	CEAT0-1741F
R2285	321-0245-00				RES., FXD, FILM:3.48K OHM, 1%, 0.125W	75042	CEAT0-3481F
R2286	321-0209-00	B010100		B142599	RES., FXD, FILM:1.47K OHM, 1%, 0.125W	91637	MFF1816G14700F
R2286	321-0210-00	B142600			RES., FXD, FILM:1.5K OHM, 1%, 0.125W	91637	MFF1816G15000F
R2287	321-0199-00				RES., FXD, FILM:15K ORM, 1%, 0.125W	75042	CEAT0-1151F
R2288	321-0273-00				RES., FXD, FILM:6.8K OHM, 1%, 0.125W	75042	CEAT0-6811F
R2289	321-0193-00				RES., FXD, FILM:1K OHM, 1%, 0.125W	75042	CEAT0-1001F
R2291	311-1225-00				RES., VAR, NONWIR 1K OHM, 20%, 0.50W	80294	3389 F-P31-102
R2292	315-0132-00				RES., FXD, CMPSN:1.3K OHM, 5%, 0.25W	01121	CB1325
R2293	321-0245-00				RES., FXD, FILM:3.48K OHM, 1%, .0.125W	75042	CEAT0-3481F
R2294	321-0255-00				RES., FXD, FILM:4.42K OHM, 1%, 0.125W	75042	CEAT0-4421F
R2295	321-0241-00				RES., FXD, FILM:3.16K OHM, 1%, 0.125W	75042	CEAT0-3161F
R2297	315-0152-00				RES., FXD, CMPSN:1.5K OHM, 5%, 0.25W	01121	CB1525
R2298	315-0102-00				RES., FXD, CMPSN:1K OHM, 5%, 0.25W	01121	CB1025
R2299	315-0431-00				RES., FXD, CMPSN:430 OHM, 5%, 0.25W	01121	CB4315

Electrical Parts List-7623A/R7623A Service

Ckt No.	Tektronix	Serial/Model No.		Name & Description	Mfr	Mfr Part
	Part No.	Eff	Dscont		Code	
R2329	323-0131-00			RES., FXD, FILM:226 OHM, 1%, 0.50W	75042	CECT0-2260F
R2331	315-0912-00			RES., FXD, CMPSN:9.1K OHM, 5%, 0.25W	01121	CB9125
R2333	321-1068-01			RES., FXD, FILM:50.5 OHM, 0.5%, 0.125W	75042	CEAT0-50R50D
R2335	321-1068-01			RES., FXD, FILM:50.5 OHM, 0.5%, 0.125W	75042	CEAT0-50R50D
R2337	321-1068-01			RES., FXD, FILM:50.5 OHM, 0.5%, 0.125W	75042	CEAT0-50R50D
R2339	321-1068-01			RES., FXD, FILM:50.5 OHM, 0.5%, 0.125W	75042	CEAT0-50R50D
R2341	315-0100-00			RES., FXD, CMPSN:10 OHM, 5%, 0.25W	01121	CB1005
R2343	321-0082-02			RES., FXD, FILM:69.8 OHM, 0.5%, 0.12W	91637	MFF1816D69R80D
R2345	315-0622-00			RES., FXD, CMPSN:6.2K OHM, 5%, 0.25W	01121	CB6225
R2347	321-0193-01			RES., FXD, FILM:1K OHM, 0.5%, 0.125W	75042	CEAT0-1001D
R2349	321-0193-01			RES., FXD, FILM:1K OHM, 0.5%, 0.125W	75042	CEAT0-1001D
R2351	322-0212-00			RES., FXD, FILM:1.58K OHM, 1%, 0.25W	75042	CEBT0-1581F
R2353	321-0082-02			RES., FXD, FILM:69.8 OHM, 0.5%, 0.125W	91637	MFF1816D69R50D
R2355	315-0622-00			RES., FXD, CMPSN:6.2K OHM, 5%, 0.25W	01121	CB6225
R2357	321-0193-01			RES., FXD, FILM:1K OHM, 0.5%, 0.125W	75042	CEAT0-1001D
R2359	321-0193-01			RES., FXD, FILM:1K OHM, 0.5%, 0.125W	75042	CEAT0-1001D
R2362	321-0044-00			RES., FXD, FILM:28 OHM, 1%, 0.125W	75042	CEAT0-28R00F
R2364	321-0069-00			RES., FXD, FILM:51.1 OHM, 1%, 0.125W	75042	CEAT0-51R10F
R2366	315-0240-00			RES., FXD, CMPSN:24 OHM, 5%, 0.25W	01121	CB2405
R2368	315-0911-00			RES., FXD, CMPSN:910 OHM, 5%, 0.25W	01121	CB9115
R2369	322-0182-00			RES., FXD, FILM:768 OHM, 1%, 0.25W	91637	MFF1421G768R0F
R2372	321-0044-00			RES., FXD, FILM:28 OHM, 1%, 0.125W	75042	CEAT0-28R00F
R2374	321-0069-00			RES., FXD, FILM:51.1 OHM, 1%, 0.12W	75042	CEAT0-51R10F
R2376	315-0240-00			RES., FXD, CMPSN:24 OHM, 5%, 0.25W	01121	CB2405
R2378	315-0911-00			RES., FXD, CMPSN:910 OHM, 5%, 0.25W	01121	CB9115
R2379	322-0182-00			RES., FXD, FILM:768 OM, 1%, 0.25W	91637	MFF1421G768R0F
R2384	321-0203-00			RES., FXD, FILM:1.27K OHM, 1%, 0.125W	75042	CEAT0-1271F
R2386	321-0141-00			RES., FXD, FILM:287 OHM, 1%, 0.125W	75042	CEAT0-2870F
R2387	321-0062-00			RES., FXD, FILM:43.2 OHM, 1%, 0.125W	75042	CEAT0-43R20F
R2390	321-0227-00			RES., FXD, FILM:2.26K OHM, 1%, 0.125W	75042	CEAT0-2261F
R2393	323-0085-00			RES., FXD, FILM:75 OHM, 1, 0.50W	75042	CECT0-75R00F
R2394	321-0203-00			RES., FXD, FILM:27K OHM, 1%, .125W	75042	CEAT0-1271F
R2396	321-0141-00			RES., FXD, FILM:287 OHM, 1%, 0.125W	75042	CEAT0-2870F
R2397	321-0062-00			RES., FXD, FILM:43.2 OHM, 1%, 0.125W	75042	CEAT0-43R20F
R2402	322-0645-00			RES., FXD, FILM:52.5ORHM, 0.5%, 0.25W	7504	CEBT0-52R50D
R2403	323-0079-00			RES., FXD, FILM:64.9 OHM, 1%, 0.50W	75042	CECT0-64R90F
R2405	323-0093-00			RES., FXD, FILM:90.9 OHM, 1%, 0.50W	75042	CECT0-90R90F
R2407	315-0511-00			RES., FXD, CMPSN:510 OHM, 5, 0.25W	01121	CB5115
R2409	311-1231-00			RES., VAR, NONWIR:25K OHM, 20%, 0.50W	80294	3389F-P31-253
R2411	311-1466-00			RES., VAR, NONWIR:2K OHM, 20%, 0.50W	73138	72PM-29-0
R2412	315-0470-00			RES., FXD, CMPSN:47 OHM, 5%, 0.25W	01121	CB4705
R2416	311-1260-00			RES., VAR, NONWIR:250 OHM, 10%, 0.50W	73138	62PT-345-0
R2418	311-1259-00			RES., VAR, NONWIR:100 OHM, 10%, 0.50W	80294	3329P-L58-101
R2419	321-0117-00			RES., FXD, FILM:162 OHM, 1%, 0.125W	75042	CEAT0-1620F
R2421	323-0134-00			RES., FXD, FILM:243 OHM, 1%, 0.50W	91637	FF1226G243R0F
R2423	321-0163-00			RES., FXD, FILM:487 OHM, 1%, 0.125W	75042	CEAT0-4870F
R2425	315-0223-00			RES., FXD, CMPSN:22K OHM, 5%, 0.25W	01121	CB2235
R2426	315-0562-00			RES., FXD, CMPSN:5.6K OHM, 5%, 0.25W	01121	CB5625
R2427	315-0562-00			RES., FXD, CMPSN:5.6K OHM, 5%, 0.25W	01121	CB5625
R2429	315-0432-00			RES., FXD, CMPSN:4.3K OHM, 5%, 0.25W	01121	CB4325
R2430	315-0471-00			RES., FXD, CMPSN:470 OHM, 5%, 0.25W	01121	CB4715
R2432	321-0297-00			RES., FXD, FILM:12.1K OHM, 1%, .125W	75042	CEAT0-1212F
R2433	311-1224-00			RES., VAR, NONWIR:500 OHM, 20%, 0.50W	80294	3389F-P31-501

REV. B JAN. 1975

Electrical Parts List-7623A/R7623A Service

Ckt No. Number	Tektronix Part No.	Serial/Model No.		Name & Description	Mfr Code	Mfr Part
		Eff	Dscont			
R2434	315-0221-00			RES., FXD, CMPSN:220 OHM, 5%, 0.25W	01121	CB2215
R2436	321-0068-00			RES., FXD, FILM:49.9 OHM, 1%, 0.125W	75042	CEATO-49R90F
R2442	315-0101-00			RES., FXD, CMPSN:100 OHM, 5%, 0.25W	01121	CB1015
R2445	315-0201-00			RES., FXD, CMPSN:200 OHM, 5%, 0.25W	01121	CB215
R2446	311-1266-00			RES., VAR, NONWIR:2.5K OHM, 10%, 0.50W	73138	62P-349-0
R2448	321-0093-00	B010100	B152724	RES., FXD, FILM:90.9 OHM, 1%, 0.125W	75042	CEATO-90R90F
R2448	321-0096-00	B152725		RES., FXD, FILM:97.6 OHM, 1%, 0.125W	91637	MFF1816G97R60F
R2455	323-0105-00			RES., FXD, FILM:121 OHM, 1%, 0.50W	75042	CECT0-1210F
R2456	321-0067-00			RES., FXD, FILM:48.7 OHM, 1%, 0.125W	91637	MFF1816G48R70F
R2458	315-0103-00			RES., FXD, CMPSN:10K OHM, 5%, 0.25W	01121	CB1035
R2461	315-0104-00			RES., FXD, CMPSN:100K OHM, 5%, 0.25W	01121	CB1045
R2463	315-0622-00			RES., FXD, CMPSN:6.2K OHM, 5%, 0.25W	01121	CB6225
R2465	315-0330-00			RES., FXD, CMPSN:33 OHM, 5%, 0.25W	01121	CB3305
R2466	315-0330-00			RES., FXD, CMPSN:33 OHM, 5%, 0.25W	01121	CB3305
R2468	315-0820-00			RES., FXD, CMPSN:82 OHM, 5%, 0.25W	01121	CB8205
R2470	308-0758-00			RES., FXD, WW:430 OHM, 1%, 7W	14193	SAX70-430ROF
R2501	322-0645-00			RES., FXD, FILM:52.5 OHM, 0.5%, 0.25W	75042	CEBT0-52R50 D
R2505	323-0093-00			RES., FXD, FILM:90.9 OHM, 1%, 0.50W	75042	CECT0-90R90F
R2507	315-0201-00			RES., FXD, CMPSN:200 OHM, 5%, 0.25W	01121	CB2015
R2509	311-1228-00			RES., VAR, NONWIR:10K OHM, 20%, 0.50W	80294	3389F-P31-103
R2510	315-0112-00			RES., FXD, CMPSN: 1.K OHM, 5%, 0.25W	01121	CB1125
R2511	311-1225-00			RES., VAR, NONWIR:K OHM, 20%, 0.50W	80294	3389F-P31-102
R2512	315-0470-00			RES., FXD, CMPSN:47 OHM, 5%, 0.25W	01121	CB4705
R2514	315-0474-00			RES., FXD, CMPSN:470K OHM, 5%, 0.25W	01121	CB4745
R2515	315-0103-00			RES., FXD, CMPSN:10K OHM, 5%, 0.25W	01121	CB1035
R2516	315-0124-00			RES., FXD, CMPSN:120K OH, 5%, 0.25W	01121	CB1245
R2517	315-0104-00			RES., FXD, CMPSN:10K OHM, 5%, 0.25W	01121	CB1045
R2519	311-1260-00			RES., VAR, NONWIR:250 OHM, 10%, 0.50W	73138	62PT-345-0
R2521	323-0134-00			RES., FXD, FILM:243 OHM, 1%, 0.50W	91637	MFF1226G243ROF
R2523	323-0176-00			RES., FXD, FILM:665 OHM, 1, 0.50W	75042	CECT0-6650 F
R2524	321-0204-00			RES., FXD, FILM:1.3K OM, 1%, 0.125W	75042	CEATO-1301F
R2526	321-0143-00			RES., FXD, FILM:301 OHM, 1%, 0.125W	75042	CEATO-3010F
R2527	311-1222-00			RES., VAR, NONWIR:100 OHM, 20%, 0.50W	80294	3386F-T04-500
R2530	315-0391-00			RES., FXD, CMPSN:390 OHM, 5%, 0.25W	01121	CB3915
R2532	321-0331-00			RES., FXD, FILM:27.4K OHM, 1%, 0.125W	75042	CEATO-2742F
R2533	321-0172-00			RES., FXD, FILM:604 OHM, 1%, 0.125W	75042	CEATO-6040F
R2534	321-0233-00			RES., FXD, FILM:2.61K OHM, 1%, 0.125W	75042	CEATO-2611F
R2536	321-0068-00			RES., FXD, FILM:49.9 OHM, 1%, 0.125W	75042	CEATO-49R90F
R2537	323-0177-00			RES., FXD, FILM:680 OHM, 1%, 0.50W	75042	CECT0-6810F
R2542	315-0101-00			RES., FXD, CMPSN:10 OHM, 5%, 0.25W	01121	CB1015
R2545	315-0201-00			RES., FXD, CMPSN:200 OHM, 5%, 0.25W	01121	CB2015
R2548	321-0093-00	8010100	B152724	RES., FXD, FILM:90.9 OHM, 1%, 0.125W	75042	CEATO-90R90F
R2548	321-0096-00	B152725		RES., FXD, FILM:97.6 OHM, 1%, 0.125W	91637	MFF1816G97R60F
R2550	321-0181-00			RES., FXD, FILM:750 OHM, 1%, 0.125W	91637	MFF1816G750R0F
R2551	321-0181-00	B01000	B152794	RES., FXD, FILM:750 OHM, 1%, 0.125W	91637	MFF1816G750R0F
R2551	321-0179-00	B152725		RES., FXD, FILM:715 OHM, 1%, 0.125W	91637	MFF1816G715R0F
R2553	301-0750-00			RES., FXD, CMPSN:75 OHM, 5%, 0.50W	01121	EB7505
R2555	323-0105-00			RES., FXD, FILM:121 OHM, 1%, 0.50W	75042	CECT0-1210F
R2565	315-0330-00			RES., FXD, CMPSN:33 OHM, 5%, 0.25W	01121	CB3305
R2566	315-0330-00			RES., FXD, CMPSN:33 OHM, 5%, 0.25W	01121	CB3305
R2568	315-0820-00			RES., FXD, CMPSN:82 OHM, 5%, 0.25W	01121	CB8205
R2570	308-0758-00			RES., FXD, WW:430 OHM, 1%, 7W	14193	SAX70-430R0F
R2593	315-0120-00			RES., FXD, CMPSN:12 OHM, 5%, 0.25W	01121	CB1205
R2597	323-0022-00			RES., FXD, FILM:16.50 OHM, 1%, 0.50W	80009	323-0022-00
RT2463	307-0181-00			RES., THERMAL:100K OHM, 10%, 4MW/DEGC	50157	JP-51JZ
RT2507	307-0127-00			RES., THERMAL:1K OHM, 1%	50157	2D1596

REV. C FEB. 1977

Electrical Parts List-7623A/R7623A Service

Ckt No.	Tektronix	Serial/Model No.		Name & Description	Mfr	Mfr Part
	Part No.	Eff	Dscont		Code	
RT2510	307-0124-00			RES., THERMAL:5K OHM, 10%	50157	1D1618
RT2517	307-0181-00			RES., THERMAL:100K OHM, 10%, 4MW /DEG C	50157	JP-51JZ
S659	260-0984-00			SWITCH, SLIDE :DP3POSN, 0.5A, 125VAC-DC	79727	G-128SPC/7140
S1000	260-0724-00	B010100	B060385	SW, THERMOSTATIC:OPEN 83.3 DEG, CL 66.7 DEG C	93410	110181
S1000	260-1759-00	B060386		SW, THERMOSTATIC:OPEN 83.3 DEG, CLOSE 66.7 DEG	14859	20700L66-322
S1001	260-1709-00			SWITCH, PUSH:POWER	77342	A9T5 762-6-3
S1011	260-1379-00			SWITCH, PUSH:TRIG SOURCE	71590	2KBC120000-595
S1021	260-1378-00			SWITCH, PUSH:VERT MODE	71590	2KBC140000-608
S10951	311-1055-00			RES., VAR, NONWIR.1K OHM 20%, 0.50W	12697	CM 40034
S1400	260-1593-00			SWITCH PUSH:FAST/VAR PERSIST/BI STABLE		OBD
S1417	260-1594-00			SWITCH PUSH:NON STORE/STORE/SAVE		OBD
S14302	311-1404-00			RES., VAR, NONWIR:5K OHM X 5K OHM, 20%, 1W	01121	13M039
S1488B,C3311-1582-00				RES., VAR, NONWIR:2 X 10K OHM, 10%	01121	12M448
S2110	260-0723-00			SWITCH, SLIDE:DPDT, 0.5 A, 125VAC	79727	GF126-0028
T523	120-0546-00			XFMR, TOROID:4 TURNS BIFILAR	80009	120-0546-00
T801	120-0708-00			XFMR, PWR, STPDN:LV	80009	120-0708-00
TI199	120-0907-01			XFMR PWR, STPDN:	80009	120-0907-01
U55	155-0011-00			MICROCIRCUIT, DI:ML, CLOCK AND CHOP BLANKING	80009	155-0011-00
U99	156-0048-00			MICROCIRCUIT, LI:FIVE NPN TRANSISTOR	86684	CA3046
U123	156-0041-00			MICROCIRCUIT, DI:DUAL D-TYPE FLIP-FLOP	27014	DM7474N
U156	156-0041-00			MICROCIRCUIT, DI:DUAL D-TYPE FLIP-FLOP	27014	DM7474N
U324	155-0022-00			MICROCICUIT, DI:ML CHANNEL SWITCH	80009	155-0022-00
US10	155-0022-00			MICROCIRCUIT, DI:ML CHANNEL SWITCH	80009	155-0022-00
U973	156-0065-00			MICROCZRKCUIT, LI:FIVE NPN TRANSISTOR ARRAY	80009	156-0065-00
U1417	156-0043-00			MICROCIRCUIT, DI:2-INPUT NOR GATE	01295	SN7402N
U1495	156-0030-00			MICROCIRCUIT, DI:QUAD 2-INPUT POS NAND GATE	01295	SN7400N
U11497	156-0043-00			MICROCIRCUIT, DI:2-INPUT NOR GATE	01295	SN7402N
U1545	156-0172-00			MICROCICUIT, DI:DUAL MONOSTABLE MV	01295	SN74123N
U1555	156-0041-00			MICROCIRCUIT, DI:DUAL D-TYPE FLIP-FLOP	27014	DM7474N
U1605	156-0172-00			MICROCIRCUIT, DI:DUAL MONOSTABLE MV	01295	SN74123N
U1615	156-0172-00			MICROCIRCUIT, DI:DUAL MONOSTABLE MV	01295	SN74123N
U2120	156-0043-00			MICROCIRCUIT, DI:2-INPUT NOR GATE	01295	SN7402N
U2126	155-0021-01			MICROCIRCUIT, DI:ML, TIMING GENERATOR	80009	155-0021-01
U2155	156-0043-00			MICROCIRCUIT, DI:2-INPUT NOR GATE	01295	SN7402N
U2159	155-0017-00			MICROCIRCUIT, DI:ML, ZERO LOGICOUNTER	80009	155-0017-00
U2180	155-0015-01			MICROCICUIT, DI:ML, ANALOG DATA SWITCH	80009	155-0015-01
U2185	155-0014-01			MICROCIRCUIT, DI:ML, ANALOG TO DECIMAL CONV	80009	155-0014-01
U2190	155-0015-01			MICROCIRUIT, DI:ML, ANALOG DATA SWITCH	80009	155-0015-01
U2232	155-0018-00			MICROCIRCUIT, DI:ZERO LOGIC	80009	155-0018-00
U2244	155-0014-01			KICROCIRCUIT, DI:ML, ANALOG TO DECIMAL CONV	80009	155-0014-01
U2250	156-0032-00			MICROCIRCUIT, DI 4-BIT BINARY COUNTER	01295	SN7493AN
U2260	155-0019-00			MICROCIRCUIT, DI:ML, DECIMAL POINT AND SPACE	80009	155-0019-00
U2270	155-0023-00			MICROCIRCUIT, DI:ML, CHAR GEN NUMERALS	80009	155-0023-00
U2272	155-0024-00			MICROCIRCUIT, DI:ML, CHAR CGEN SPCL SYMBOLS	80009	155-0024-00
U2274	155-0025-00			MICROCIRCUIT, D :ML, CHAR GEN PREFIXES	80009	155-0025-00
U2276	155-0026-00			MICROCICUIT, DI:ML, CHAR GEN LETTES	80009	155-0026-00
U2278	155-0027-00			MICROCIRCUIT, DI:ML, CHAR GEN SPCL ALPHA	80009	155-0027-00
U2284	155-0020-00			ICROCIRCUIT, DI:ML, CHANNEL SW OUTPUT ASSY	80009	155-0020-00
U2340	155-0022-00			MICROCIRCUIT, DI:ML CHANNEL SWITCH	80009	155-0022-00
V1265	154-0723-00			ELECTRON TUBE:CRT	80009	154-0723-00
VR851	152-0283-00			SEMICONDD DEVICE:ZENER, 0.4W;43V, 5%	04713	1N976B

¹Furnishd as a unit with R1095.

²Furnishd as a unit with R1430.

³Furnished as a unit with R1488A, B

Electrical Parts List-7623A/R7623A Service

Ckt No. Number	Tektronix Part No.	Serial/Model No.		Name & Description	Mfr Code	Mfr Part
		Eff	Dscont			
VR890	152-0124-00			SEMICOND DEVICE:ZENER, 0.5W, 9V, 5%	04713	1N938A
VR1109	152-0055-00			SEMICOND DEVICE:ZENER, 0.4W, 11V, 5%	04713	1N962B
VR1151	152-0255-00			SEMICOND DEVICE:ZENER, 0.4W, 51V, 5%	04713	1N978B
VR1233	152-0286-00			SEMICOND DEVICE:ZENER, 0.4W, 75V, 5%	04713	1N982B
VR1707	152-0280-00			SEMICOND DEVICE:ZENER, 0.4W, 6.2V, 5%	04713	1N753A
VR1793	152-0280-00			SEMICOND DEVICE:ZENER, 0.4W, 6.2V, 5%	04713	1N753A
VR1831	152-0289-00			SEMICOND DEVICE:ZENER, 0.4W, 180V, 5%	07910	1N991B
VR2262	152-0405-00			SEMICOND DEVICE:ZENER, 1W, 15V, 5%	99942	1N5567B
VR2263	152-0405-00			SEMICOND DEVICE:ZENER, 1W, 15V, 5%	99942	1N5567B
VR2264	152-0405-00			SEMICOND DEVICE:ZENER, 1W, 15V, 5%	99942	1N5567B
VR2445	152-0279-00			SEMICOND DEVICE ZENER, 0.4W, 5.1V, 5%	07910	1N751A
VR2545	152-0279-00			SEMICOND DEVICE.ZENER, 0.4W, 5.1V, 5%	07910	1N751A

VOLTAGES AND WAVEFORMS

Equipment Required:

- | | | | |
|--------------------------------------|----------------------------|----|----------------|
| 1. | Digital voltmeter (DVM) | 9. | Time-base unit |
| 2. 100X probe | 10. Three-inch screwdriver | | |
| 3. Test oscilloscope | | | |
| 4. Low-frequency signal generator | | | |
| 5. Medium-frequency signal generator | | | |
| 6. 10X probe | | | |
| 7. 50 ohm BNC cables (two) | | | |
| 8. Amplifier unit | | | |

Ten points and adjustment are shown on Figure 8-16.

Control Settings

Preset the 7623A controls as follows

VERT MODE	LEFT
TRIG SOURCE	VERT MODE
INTENSITY	CCW (off)
READOUT INTENSITY	Off (in detent)
Display Selection	NON STORE
ERASE/PERIODIC	CCW (in detent, off)
PERSISTENCE	CCW (maximum)
Storage Selection	BISTABLE
SAVE INTENSITY	CW
STORAGE LEVEL	CW

1. CHECK NON STORE VOLTAGE LEVELS

- a. Install a time-base unit in the horizontal compartment of the 7623A and an amplifier unit in the left vertical compartment.

- b. Set the me-base unit for auto, ac-coupling, and line source at a sweep rate of 0.2 millisecond/division.
- c. Set the amplifier unit for 0.5 volt/division vertical deflection and dc coupling.
- d. Check the dc levels on the following test points with the DVM.
 - Front Mesh More negative than -12 volts
 - Fast Mesh 125 volts ± 4 volts
 - Collector 150 volts ± 6 volts
 - CE 3 65 volts ± 5 volt
 - CE 2 45 volts ± 2 volts
 - CE 1 70 volts ± 3 volts
 - FGA 36 volts ± 1.5 volts
 - FGK At least one volt but not more than three volts above FGA

2. CHECK BISTABLE VOLTAGE LEVELS

- a. Press the STORE pushbutton
- b. Check the dc levels on the following test points with the DVM
 - Front Mesh Adjustable from 45 volts to 95 volts with R1689
 - Fast Mesh 125 volts ± 5 volt
 - Collector 150 volts ± 6 volts
 - CE 3 85 volts ± 5 volts
 - CE 2 85 volts ± 5 volts
 - CE 1 45 volts ± 2.5 volts
 - FGA 36 volts ± 3 volts
 - FGK 0 volts (approximately)
- c. Connect the DVM to CE 1
- d. the ERASE pushbutton.
- e. 85 volts ± 4 volts during the erase cycle.
- f. Remove the DVM probe from CE 1 and connect it to FGA
- g. the ERASE pushbutton.
- h. 90 volts ± 4 volts during the erase cycle
- i. the DVM

3. CHECK BISTABLE ERASE WAVEFORMS

- a. the time-base unit for single sweep.
- b. a 100X probe from the test oscilloscope to the Front Mesh test point.
- c. the test oscilloscope for a sweep rate of 100 milliseconds/division and a vertical deflection of one volt/division (100 volts/division at probe tip).
- d. the ERASE pushbutton.
- e. for a 100-millisecond, approximately 60volt erase pulse. At the end of the erase pulse, the level should drop below zero volts and ramp up to the Op Level in less than 375 milliseconds.

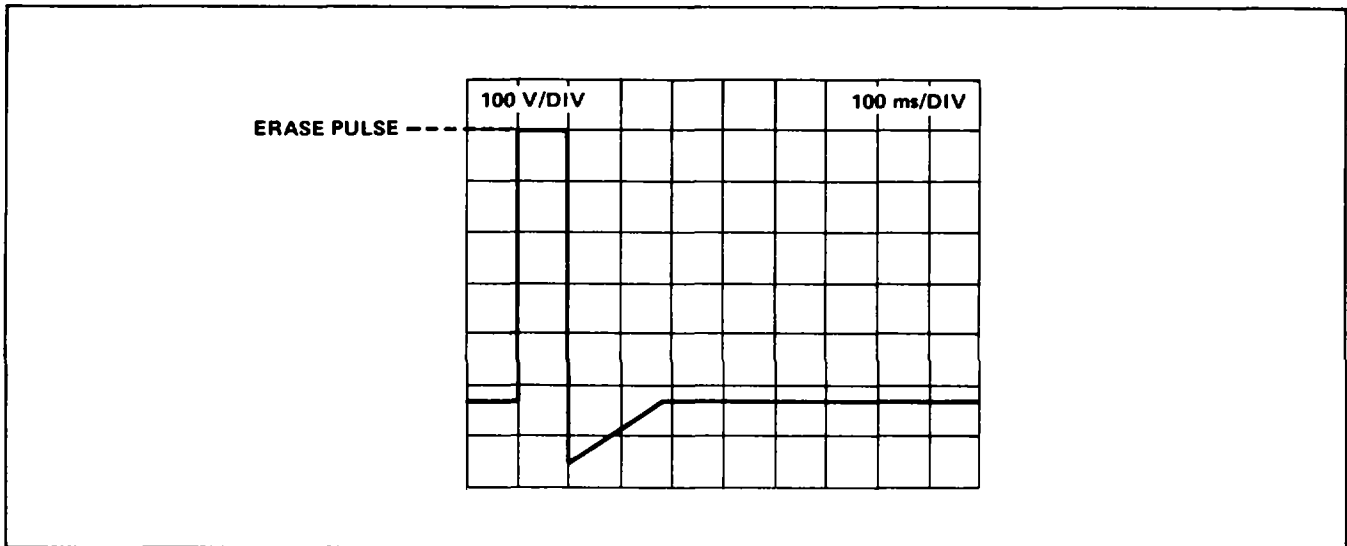
*Idealized Erase waveform.*

- f. the FAST pushbutton (on).
- g. the ERASE pushbutton.
- h. for the same waveform as in step e but with a 100-millisecond, 600-volt transfer pulse approximately one second after the erase pulse

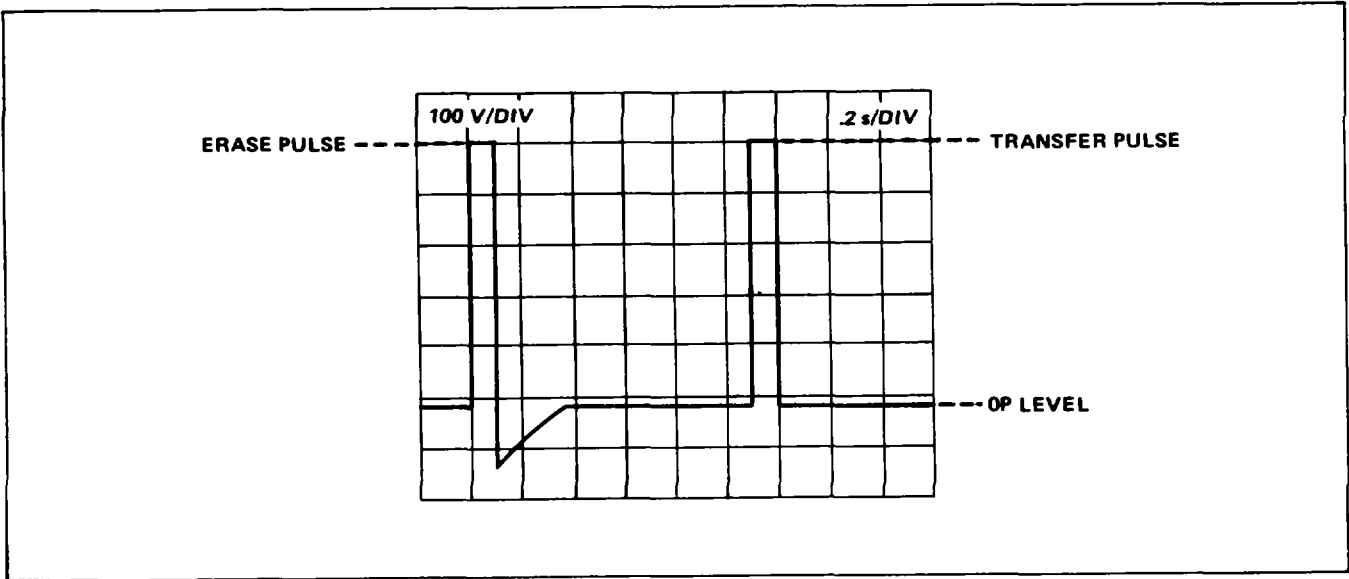

Idealized Erase and Transfer waveform.

4. CHECK VAR PERSST VOLTAGE LEVELS

- a. the m-base unit for auto triggering.
- b. the VAR PERSIST pushbutton and measure the voltages on the following test points with the DVM.

FAST MESH	100 volts ± 4 volts
COLL	100 volts ± 4 volts
CE 3	65 volts ± 4 vol
CE 2	45 volts ± 2 volts
CE 1	30 volts ± 1 5 volts
FGA	20 volts ± 1 volt
FGK	0 volt ± 0.5 volt

- c. the voltages on the following test points during erase

Test Point	Normal	During Erase
FAST MESH	100 volts	125 volts±3 volts
COLL	100 volts	132 volts±3 vdots
CE 1	30 volts	68 volts ± 3 volts
FGA	20 volts	74 volts ± 3 volts

5. CHECK VAR PERSIST RAMP

- a. the test oscilloscope for 0.1 volt/division (1 volt/division at probe tip) vertical deflection, ac input, and 0.1 millisecond/division sweep rate

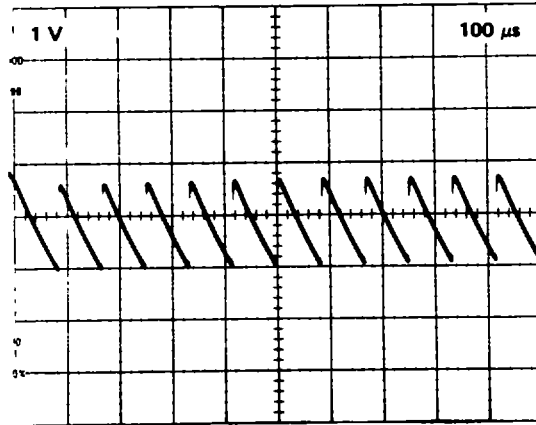

VAR PERSIST Front M s ramp.

- b. a 10X probe from the test oscilloscope to the Front Mesh of the 7623A.
 - c. the STORAGE LEVEL control fully clockwise
 - d. -For a 0kilohertz approximately two-volt ramp on the front mesh
- 6. CHECK PERSISTENCE PULSES**
- a. the PERSISTENCE control fully clockwise
 - b. CHECK-For a pulse, the same amplitude as the prep pulse, 1.2 milliseconds to 2.2 milliseconds wide riding on the VP Op Level
 - c. CHECK-For 7.5 to 12. milliseconds between leading edges (10Ghertz repetition rate).
 - d. Press the SAVE pushbutton.
 - e. CHECK-That the persistence pulses stop
 - f. Press the ERASE pushbutton.
 - g. -That the erase waveform does not occur
 - h. the STORE pushbutton
 - i. the test oscilloscope sweep rate to five microseconds/division
 - j. the PERSISTENCE control slowly counterclockwise and check that the persistence pulse decreases to less than 15 microseconds near the counterclockwise end of the control and disappears at the counterclockwise end.
 - k. the 10X probe and press the NON STORE pushbutton

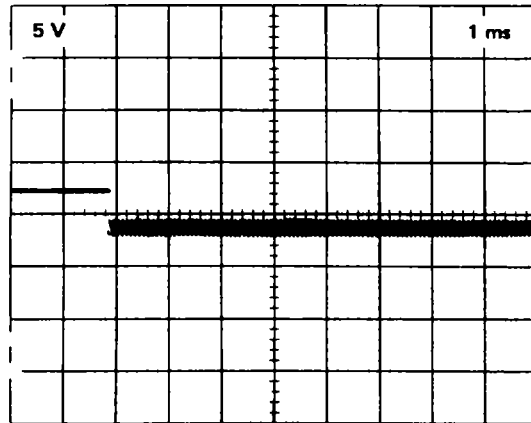

PERSISTENCE pulses.

7. CHECK VAR PERSIST FAST VOLTAGE LEVELS

- a. Turn the INTENSITY off and press the FAST pushbutton
- b. Adjust the FAST LEVEL CENTER control fully counterclockwise.
- c. Adjust the me-base unit Level control so that the triggered light is off
- d. Press the ERASE pushbutton.
- e. Adjust the DVM to the following test points and measure the voltage levels
 - CE 3 72.5 volts \pm 4 volts
 - CE 2 55 volts \pm 2.5 volts

8. CHECK BISTABLE FAST VOLTAGES

- a. Press the BISTABLE pushbutton.
- b. Set the test oscilloscope for two volts/division (20 volts/division at probe tip) vertical deflection at a sweep rate of two microseconds/division
- c. Connect a 10X probe from the test oscilloscope to the Fast Mesh test point.
- d. Turn the 7623A timebase unit Level control for untriggered sweep (time-base unit should still be set for single sweep).
- e. Press the ERASE pushbutton

- f. -For approximately 15 volts on the Fast Mesh test point.
- g. -For pump pulses on the Fast Mesh test point that go from approximately 15 volts to approximately 125 volts. It may be necessary to increase the intensity of the test oscilloscope and trigger on the positive slope
- h. CHECK-That the pulse in step g is of approximately two microseconds duration.
- i. the 10X probe.
- j. the voltage levels on the following test points using the DVM
 - COLL 128 volts \pm 3 volts
 - CE 3 65 volts \pm 5 volts
 - CE 2 45 volts \pm 2 volts
 - CE 1 30 volts \pm 2 volts
 - FGA 20 volts \pm 2 volts
- k. the DVM to the Collector test point.
- l. Press the ERASE pushbutton.
- m. CHECK-That the voltage drops to approximately 115 volts during erase cycle
- n. the DVM.

REPLACEABLE MECHANICAL PARTS

PARTS ORDERING INFORMATION

Replacement parts are available from or through your local Tektronix Inc Field Office or representative. Changes to Tektronix instruments are sometimes made to accommodate improved components as they become available and to give you the benefit of the latest circuit improvements developed in our engineering department. It is therefore important, when ordering parts, to include the following information in your order: Part number, instrument type or number, serial number, and modification number, applicable.

If a part you have ordered has been replaced with a new or improved part, your local Tektronix Inc. Field Office or representative will contact you concerning any change in part number.

Change information if any, is located at the rear of this manual.

SPECIAL NOTES AND SYMBOLS

- X000 Part first added at this serial number
00X Part removed after this serial number

FIGURE AND INDEX NUMBERS

Items in this section are referenced by figure and index number to the illustrations

INDENTATION SYSTEM

This mechanical parts listed to indicate item relationships. Following is an example of the indentation system used in the description column.

- 1 2 3 4 5 Name & Description
Assembly and/or Component
Attaching parts for Assembly and/or Component
---*---
Detail Part of Assembly and/or Component
Attaching parts for Detail Part
---*---
Parts of Detail Part
Attaching parts for Parts of Detail Part
---*---

Attaching Parts always appear in the same indentation as the item it mounts, while the detail parts are indented to the right. Indented items are part of, and included with the next higher indentation. The separation symbol ----*--- indicates the end of attaching parts.

Attaching parts must be purchased separately, unless otherwise specified.

ITEM NAME

In the Parts List, an Item Name is separated from the description by a colon (:) Because of space limitations an Item Name may sometimes appear as incomplete. For further Item Name identification, the U S Federal Cataloging Handbook H6-1 can be utilized where possible.

ABBREVIATIONS

Table with 8 columns of abbreviations and their corresponding full names, such as INCH, NUMBER, SIE, ELEC, ELECTRICAL, etc.

CROSS INDEX MFR.CODE NUMBER TO MANUFACTURER

MFR.CODE	MANUFACTURER	ADDRESS	CITY, STATE, ZIP
0000C	GETTIG ENGINEERING AND MANUFACTURING CO.		SPRNGMILL, PA 16875
00779	AMP INC.	P.O.BOX 3608	HARRISBURG, PA 17105
01009	ALDEN PRODUCTS CO.	117 N.MAIN ST.	BRCKTON, HA 02403
01295	TEXAS INSTRUMENTS, INC., SEMICONDUCTOR GROUP	P.O.BOX SO12	DALLAS, TX 75222
05624	BARBER-COLMAN CO.	1300.	CKFORD, IL 61101
05820	WAKEFIELD ENGINEERING, INC.	AUDUBON ROAD	WAKEFIEL, HA 01880
06515	AERO CRAFT AND HISSLE PROOUCTS	16300-D EAST ARROW HWY	IRWINDALE, CA 91706
06540	AMATONELECTRONIC HARDWARE, DIV.OF MITE CORP.	446 BLAKE ST.	NEW HAVEN, CT 06515
06982	MOORE, HOWARD J., CO.	105 E.16TH ST.	NEW YORK, NY 10003
08261	SPECTRA-STRIP CORP.	7100 LAMPSON AVE.	GARDEN GROVE CA 92642
12327	FREEWAY CORP	9301 ALLEN DR.	CLEVELAND, OH 44125
12360	ALBANY PRODUCTS CO., DIV.OF PNEUMO DYNAMICS CORP.	351 CONNECTICUT AVE.	SOUTH NORIALK, CT 06856
16428	BELDEN CORP.	P.O.BOX 1101	RICHMOND, IN 47374
22526	BERG ELECTRONICS, INC.	YOUK EXPRESSWAY	NEW CUMBERLAND, PA 17070
23753	U.I.D.ELECTRO NICS CORP.	4105 PEMBRK8E = D.	HOLLYWOOD, i 33021
23499	GAVITT WIRE AND CABLE, DIVISION OF RSC INDUSTRIES, INC.	455 N.QUINCE ST.	ESCONDIO, CA 92025
24655	ENERAL RADIO	300 BAKER AVE.	CONCORD, HA 01742
24931	SPECIALTY CONNECTOR CO., NC.	3560 ADISON AVE.	INDIANAPOLIS, IN 46227
26365	GRIES REPRODUCER CO., DIV.OF COATS AND CLARK INC.	125 BEECHWOOD AVE.	NEW IRCELLE, NY 10802
28520	HEYMAN MFG.CO.	147 N.MICHIGAN AVE.	KENILWORTH, NJ 07033
28875	IMC MAGNETICS CORP., NEW HAMPSHIRE DIV.	ROU TE 16	ROCHESTER, NH 03867
52792	THOGREN TOOL AND OLDING CO., INC.	1100 EVANS AVE.	VALPARAISO, IN 46383
70276	AL-EN MFG.CO.	P.O.DRAWER 570	HARTFORD, CT 06101
70318	ALLMETAL SCREW PRODUCTS CO., INC.	821 STEWART AVE.	GARDEN CITY,NY 11530
71159	BRISTOL SOCKET SCREW, DIV.OF AMERICAN CHAIN AND CABLE CO., INC.	40 BRISTOL ST.	WATERBURY, CT 06720
71279	CAMBRIDGE THERMIONIC CORP.	445 CONCORD AVE.	CAMBRIDGE, MA 02138
71590	CENTRALAB ELECTRONICS, DIV.OF GLOBE-UNION, INC.	5757 N.GREEN BAY AVE.	MILWAUKEE, WI 53201
71785	TRW ELECTRONIC COMPONENTS, CINCH CONNECTOR OPERATIONS	1501 MORSE AVE.	ELK GROVE VILLAGE, IL 60007
72653	G.C.ELECTRONICS CO., A DIVISION OF HYDROMETALS, INC.	400 S.WYMAN ST.	ROCKFORD, IL 61101
72982	ERIE TECHNOLOGICAL PRODUCTS, INC.	644 W.12TH ST.	ERIE, PA 16512
73743	FISCHER SPECIAL MFG.CO.	446 MORGAN ST.	CINCINNATI, OH 45206
74445	HOLO-KROME CO.	31 BROOK ST.WEST	HARTFORD, CT 06110
74921	ITEN FIBRE CO., THE	4001 BENEFIT AVE.	ASHTABULA, OH 44004
75915	LITTELFUSE, INC.	800 E.NORTHWEST HWY	DES PLAINES, IL 60016
77250	PHEOLL MANUFA CTURING CO., DIVISION OF ALLIED PRODUCTS CORP.	5700 W.ROOSEVELT m.	CHICAGO, IL 60650
77342	AMF, INC., POTTER AND BRUNFIELD DIV.	1200 E.BROADWAY	PRINCETON,IN 47570
78189	ILLINOIS TOOL WORKS, INC. SHAKEPIROOF DIVISION	ST.CHARLES ROAD	ELGIN, IL 60120
79727	C-W INDUSTRIES	550 DAVISVILLE R.	WARMINSTER, PA 18974
79807	WROUGHT WASHER MFG.CO.	2100 S.O BAY ST.	MILWAUKEE, WI 53207
80009	TEKTRONIX, INC.	P..BOX 500	BEAVERTON, OR 97077
83385	CENTRAL SCREW CO.	2530 CRESCENT DR.	BROADVIEW, IL 60153
83501	GAVITT WIRE AND CABLE, DIVISION OF RSC INDUSTRIES, INC.	CENTRAL ST.	BROOKFIELD, HA 01506
86445	PENN FIBRE AND SPECIALTY CO., IN.	2032 E.WEST.ORELAND ST.	PHILADELPHIA, PA 19134
95987	WECKESSER CO., INC.	4444 WEST IRVING PARK RD.	CHICAGO, IL 60641

Mechanical Parts List--7623A/R7623A Service

Fig. & Index No.	Tektronix Part No.	Serial/Model No Eff Dscnt	Qty	1 2 3 4 5 Name & Description	Mfr Code	Mfr Part Number
1-1	390-0345-00		2	CABINET SIDE:LEFT AND RIGHT	80009	390-0345-00
	-----		-	.EACH CABINET SIDE INCLUDES:		
-2	386-1151-00		2	.PLATE, LATCH LKG:	80009	386-1151-00
-3	386-0227-00		2	.PL, LATCH RNDEX:	80009	386-0227-00
-4	214-0604-00		2	.WASH., SPG TNSN:0.26 ID X 0.47 INCH OD	80009	214-0604-00
-5	214-0603-01		2	.PIN, SECURING:0.27 INCH LONG	80009	214-0603-01
-6	343-0256-00		2	RTNR BLK, SCOPE:	80009	343-0256-00
				(ATTACHING PARTS FOR EACH)		
-7	211-0578-00		2	SCREW, MACHINE:6-32 X 0.438 1NCH, PNH STL	83385	OBD
				---*---		
-8	390-0204-00		1	COVER, SCOPE:	80009	390-0204-00
				(ATTACHING PARTS)		
-9	211-0503-00		4	SCREW, MACHINE:6-32 X 0.188 INCH, PNH STL	83385	OBD
-10	348-0073-00		2	SPT PIVOT, FLIP:LEFT FRONT AND RIGHT REAR	80009	348-0073-00
				(ATTACHING PARTS FOR EACH)		
-11	211-0532-00		2	SCREW, MACHINE=6-32 X 0.75 INCH, FILH STL	83385	OBD
				---*---		
	386-3286-00	XB091130	1	PLATE, GND:BAIL	80009	386-3286-00
-12	348-0074-00		2	SPT PIVOT, FLIP:RIGHT FRONT AND LEFT REAR	80009	348-0074-00
				(ATTACHING PARTS FOR EACH)		
-13	211-0532-00		2	SCREW, MACHINE:6-32 X 0.75 INCH, FILH STL	83385	OBD
				---*---		
-14	377-0119-00		4	INSERT, FOOT:	80009	377-0119-00
-15	426-0514-00		1	FRME, HASK:PLASTIC	80009	426-0514-00
-16	378-0625-02		1	FILTER, LT, CRT:GRAY	80009	378-0625-02
-17	331-0258-03		1	ASK, CR SCALE:	80009	331-0258-03
-18	200-0939-01		1	BEZEL, CRT:	80009	200-0939-01
				(ATTACHING PARTS)		
-19	212-0023-00		4	SCREW, MACHINE:8-32 X 0.375 INCH, PNH STL	83385	OBD
				---*---		
	131-1022-00	XB040000	2	2CONTACT, ELEC:CRT MASK	80009	131-1022-00
-20	337-1159-00		1	WINDOW, OBS:4.78 X 3.93 X 0.07"PLSTC	80009	337-1159-00
-21	331-0245-00		1	MAS, CRT SCALE:	80009	331-0245-00
-22	333-1691-00		1	PANEL, FRONT:LEFT	80009	333-1691-00
-23	386-1884-03		1	SPRT, ELCTWV B:	80009	386-1884-03
				(ATTACHING PARTS)		
-24	212-0040-00		2	SCREW, MACHINE:8-32 X 0.375 100 DEG, FLH STL	83385	OBD
-25	211-0510-00		2	SCREW, MACHINE:6-32 X 0.375 INCH, PNH STL	83385	OBD
				---*---		
	-----		-	.SUPPORT INCLUDES:		
-26	386-1517-00		4	.SUPPORT, CRT:	80009	386-1517-00
-27	204-0380-00		1	BODY, TERMINAL	80009	204-0380-00
-28	131-0765-00		3	3 CONTACT, ELEC:	80009	131-0765-00
-29	348-0031-00		1	GROMMET, PLASTIC:O.156 INCH DIA	80009	348-0031-00
-30	-----		1	CKT BOAR ASSY:GRATICULE LIGHT(SEE A16 EPL)		
			-	.CKT BOAR D ASSY INCLUDES:		
-31	378-0614-00		1	.REFLECTOR, LIGHT:	80009	378-0614-00
-32	344-0179-00		2	.CLIP, REFL RTNG:PLASTIC	80009	344-0179-00
-33	211-0062-00		2	.SCREW, MACHINE:2-56 X 0.312 INCH, RDH STL	83385	OBD
-34	366-1519-00		1	KNOB:PULL	80009	366-1519-00
			-	.KNOB INCLUDES:		
	213-0725-00		2	.SETSCREW:3-48 X 0.094 INCH, HEX SOC STL	71159	OBD
35	366-1077-00		3	KNOB GRAY	80009	366-1077-00
			-	.EACH KNOB INCLUDES:		
	213-0153-00		1	.SETSCREW:5-40 X 0.125 INCK, HEX SOC STL	74445	OBD
-36	366-1391-00		1	KNOB:GRAY	80009	366-1391-00
-37	366-1215-00		1	KNOB:GRAY	80009	366-1215-00
			-	.KNOB INCLUDES:		
	213-0153-00		1	.SETSCRW:5-40 X 0.125 INCH, HEX SOC STL	74445	OBD
-38	366-1519-01		1	KNOB :MAN	80009	366-1519-01
			-	.KNOB INCLUDES:		
	213-0725-00		2	.SETSCREW:3-48 X 0.094 INCH, HEX SOC STL	71159	OBD

REV. E JAN 1976

Mechanical Parts List--7623A/R7623A Service

Fig. & Index No.	Tektronix Part No.	Serial/Model No Eff Dscont	Qty	1 2 3 4 5 Name & Description	Mfr Code	Mfr Part Number
1-39	366-1391-00		1	KNOB GRAY	80009	366-1391-00
	-----			.KNOB -INCLUDES:		
	213-0140-00		1	.SESCREW:2-56 X 0.94 INC, HEX SOC STL	70276	OBD
-40	366-1480-02		1	PUSH BUTTON:ON-OFF	80009	366-1480-02
-41	366-1402-12		1	PUSH BUTTON:FAST	80009	366-1402-12
-42	366-1402-25		1	PUSH BUTTON:VAR PERSISTANCE	80009	366-1402-25
-43	366-1402-13		1	PUSH BUTTON:BISTABLE	80009	366-1402-13
-44	426-0681-00		15	FR, PUSH BUTTON:GRAY PLASTIC	80009	426-0681-00
-45	358-0378-00	B001100 B129999	3	BUSHING, SLEEVE:PRESS MOUNT	80009	358-0378-00
	358-0378-00	B130000	2	BUSHING, SLEEVE:PRESS MOUNT	80009	358-0378-00
-46	-----		3	RES., VAR:(SEE R1430, R1095, R1488A, B EPL) (ATTACHING PARTS FOR EACH)		
-47	210-0583-00		1	NUT, PLAIN, HEX.:0.25-32 X 0.312 INCH, BRS	73743	2X20319-402
-48	210-0940-00		1	WSHER, FLAT:0.25 ID X 0.375INCH OD, STL	79807	OBD
	-----			---*---		
-49	-----		1	RES., VAR:(SEE R1472A, B EPL) (ATTACHING PARTS)		
-50	210-0583-00		1	NUT, PLAIN, HEX.:0.25-32 X 0.312 INCH, BRS	73743	2X20319-402
	210-0940-00		1	WASHER, FLAT:0.25 ID X 0.375 INCH OD, STL	79807	OBD
-51	210-0223-00		1	TERMINAL, LUG 5 INCH DIA, SE	78189	2101-14-03-2520N
	-----			---*---		
-52	333-1843-00	B010100 B129999	1	PANEL, FRONT:	80009	333-1843-00
	333-1843-01	B130000	1	PANEL, FRONT:	80009	333-1843-01
-53	-----			CKT BOARD ASSY:MODE SWITCH(SEE A17 EPL) (ATTACHING PARTS)		
-54	211-0101-00		2	SCREW, MACHINE:4-40 X 0.25" 100 DEG, FL STL	83385	OBD
	-----			.CKT BOARD ASSY INCLUDES:		
-55	131-0608-00		9	.CONTACT, ELEC:0.365 INCH L ONG22526	47357	
-56	260-1593-00		1	.SWITCH PUSH:FAST/VAR PERSIST/BI STABLE		OBD
-57	361-0411-00		5	.SPACER, PUSH SW:0.13 W X 0.375 INCH L, PLSTC	71590	J64285-00
-58	211-0062-00		2	.SCREW, MACHINE:2-56 X 0.312 INCH, RDH STL	83385	OBD
-59	220-0637-00		1	.NUT BLOCK.4-40/2-56 INCH THREADS	80009	220-0637-00
-60	136-0387-01		1	JACK, TIP:BLACK	71279	4352-1-0310
-61	136-0387-00		3	JACK, TIP:GRAY	71279	4352-1-0318
-62	132-0027-00		2	ADAPTER, CA TO C:	24655	0874-6540
	-----			(ATTACHING PARTS FOR EACH)		
-63	212-0040-00		1	SCREW, MACHINE:8-32 X 0.375 100 DEG, FLH STL	83385	OBD
	-----			---*---		
-64	386-2119-00		1	SUBPANEL, FRONT: (ATTACHING PARTS)	80009	386-2119-00
-65	211-0538-00		4	SCREW, MACHINE:6-32 X 0.312"100 DEG, FLH STL	83385	OBD
	211-0589-00		2	SCREW, MACHINE:6-32 X 0.312 INCH, PNH BRS	83385	OBD
	-----			---*---		
-66	348-0282-00		1	STAND, ELEC EQPT:	80009	348-0282-00
-67	348-0278-00		2	SHLD GSKT, ELEC:	80009	348-0278-00
-68	351-0295-00		3	GUIDE, SLIDE:	80009	351-0295-00
	-----			(ATTACHING PARTS FOR EACH)		
-69	213-0088-00	B010100 B080984	1	SCR, TPG, THD CTG:4-24 X 0.25 INCH, PNH STL	83385	OBD
	213-0054-00	B080985	3	SCR, TPG, THD FOR:6-32 X 0.312 INCH, PNH STL	83385	OBD
	-----			---*---		
-70	384-1058-00		1	EXTENSION SHAFT:8.157 INCH LONG	80009	384-1058-00
-71	351-0179-00		1	GUIDE, CKT CARD: (ATTACHING PARTS)	80009	351-0179-00
	211-0101-00		2	SCREW, MACHINE:4-40'X 0.25" 100 DEG, FLH STL	83385	OBD
	-----			---*---		
-72	210-0202-00		1	TERMINAL, LUG:SE #6 (ATTACHING PARTS)	78189	2104-06-00-2520N
-73	211-0559-00		1	SCREW, MACHINE:6-32 X 0.375"100 DEG, FLE STL	83385	OBD
-74	210-0457-00		1	NUT, PLAIN, EXT W:6-32 X 0.312 INCH, STL	83385	OBD
	-----			---*---		
	644-0056-00		1	POWER SW ASSY: (ATTACHING PARTS)	80009	644-0056-00
-75	211-0559-00		2	SCREW, MACHINE:6-32 X 0.375"100 DEG, FLH STL	83385	OBD
-76	210-0457-00		2	NUT, PLAIN, EXT W:6-32 X 0.312 INCH, STL	83385	OBD
	-----			---*---		

Mechanical Parts List--7623A/R7623A Service

Fig. & Index No.	Tektronix Part No.	Serial/Model No Eff Dscont	Qty	1 2 3 4 5 Name & Description	Mfr Code	Mfr Part Number
-77	407-1570-00		-	.POWER SWITCH ASSY INCLUDES:	80009	407-1570-00
-78	211-0008-00		1	.BRACKET, ANGLE:POWER SWITCH	83385	OBD
-79	200-1731-00		2	.SCREW, MACHINE: 4-40 X 0.25 INCH, PNH STL	80009	200-1731-00
-80	211-0034-00		1	.COVER, ELEC SW:	77250	OBD
-81	210-0850-00		1	.SCREW, MACHINE:2-56 X 0.500 INCH, PNH, STL	12327	OBD
-82	210-0405-00		1	.WASHER, FLAT:0.093 ID X 0.281 INCH OD, STL	73743	2XI2157-402
-83	260-1709-00		1	.NUT, PLAIN, HEX.:2-56 X 0.188 INCH, BRS	77342	A9T5 762-6-3
-84	131-0799-00		1	.SWITCH PUSH:POWER	80009	131-0799-00
			2	CONTACT, ELEC= (ATTACHING PARTS FOR EACH)		
-85	211-0008-00		1	SCREW, MACHINE:4-40 X 0.25 INCH, PNH STL	83385	OBD
-86	210-0586-00		1	NUT, PLAIN, EXT W:4-40 X 0.25 INCH, STL ---*---	78189	OBD
-87	131-0930-00			CONTACT, ELEC:PLUG-IN GROUND (ATTACHING PARTS FOR EACH)	80009	131-0930-00
-88	211-0008-00		1	SCREW, MACHINE:4-40 X 0.25 INCH, PNH STL	83385	OBD
-89	210-0586-00		1	NUT, PLAIN, EXT W:4-40 X 0.25 INCH, STL ---*---	78189	OBD
-90	131-1018-00		4	CONTACT, ELEC:PLUG-IN GROUND (ATTACHING PARTS FOR EACH)	80009	131-1018-00
-91	211-0008-00		1	SCREW, MACHINE:4-40 X 0.25 INCH, PNH STL	83385	OBD
-92	210-0586-00		1	NUT, PLAIN, EXT W:4-40 X 0.25 INCH, STL ---*---	78189	OBD
-93	343-0004-00		1	CLAMP, LOOP:0.312 INCH DAMETER, PLSTC (ATTACHING PARTS)	95987	5-16-6
-94	211-0538-001		1	SCREW, MACHINE:6-32 X 0.312"100 DEG, FLH STL	83385	OBD
-95	Z10-0863-0 0		1	WSHR, LOOP CLAP:FOR 0.50" WIDE CLAMP, STL	95987	C191
-96	210-0457-00		1	NUT, PLAIN, EXT W:6-32X 0.312 INCH, STL ---*---	83385	OBD
-97	210-0202-00		1	TERMINAL, LUG:SE #6 (ATTACHING PARTS)	78189	2104-06-00-2520N
-98	211-0510-00		1	SCREW, MACHINE:6-32 X 0.375 INCH, PNH STL	83385	OBD
-99	210-0457-00		1	NUT, PLAIN, EXT W:6-32 X 0.312 INCH, STL ---*---	83385	OBD
-100	-----		1	CKT BOARD ASSY:LOGIC(SEE AZ EPL)		
	-----		-	CKT BOARD ASSY INCLUDES:		
-101	131-0566-00		1	LINK, TERM.CONNE:0.086 DIA X 2.375 INCH L	0000C	L-2007-1
-102	136-0235-00		1	SOCKET, PLUG-IN:6 CONTACT, ROUND	71785	133-96-12-062
-103	136-0252-04	B010100 101049	24	CONTACT, ELEC:0.188 INCH LONG	22526	75060
	136-0350-00	B010150	8	SOCKET, PLUG-IN:3 PIN, LOW PROFILE	80009	136-0350-00
-104	136-0260-01		1	SOCKET, PLUG-IN:16 CONTACT, RECT SHAPE	71785	133-51-02-075
-105	136-0263-03	B010100 B111714	33	CONTACT, ELEC:FOR 0.025 INCH SQUARE PIN	00779	86250-2
	136-0263-04	B111715	33	CONTACT, ELEC:FOR 0.025 INCH SQUARE PIN	22526	75377-001
-106	136-0269-02		3	SOCKET, PLUG-IN:14 CONTACT, OW CLEARANCE	01295	C931402
-107	214-0579-00		4	TERM., TEST PT:0.40 INCH LONG	80009	214-0579-00
-108	---		1	CT BOARD ASSY:AIN INTERFACE(SEE A EPL) (ATTACHING PARTS)		
-109	213-0034-009		9	SCR, TPG, THD CTG:4-40 X 0.188 INCH, PNH STL ---*---	83385	OBD
-110	131-0608-00		-	.CKT BOARD ASSY INCLUDES:		
	131-0592-00		86	.CONTACT, ELC:0.365 INCH LONG	22526	47357
-111	131-0591-00		24	.CONTACT, ELEC:0.885 INCH LONG	22526	47353
	131-0589-00		33	.CONTACT, ELEC:0.835 INCH LONG	22526	47352
			4	.CONTACT, ELEC:0.46 INCH LONG	22526	47350
-112	129-0308-00		3	.POST, EL C-MECH:HEX., 0.25 X 0.465 INCH LONG (ATTACHING PARTS FOR EACH)	80009	129-0308-00
-113	211-0008-00		1	.SCREW, MACHINE:4-40 X 0.25 INCH, PNH STL ---*---	83385	OBD
-114	129-0308-001			.POST, EEC-MECH:HEX., 0.25 X 0.465 INCH LONG (ATTACHING PARTS)	80009	129-0308-00
	211-0008-00		1	.SCREW, MACHINE:4-40 X 0.25 INCH, PNH STL	83385	OBD
-115	210-0803-00		1	.WASHER, FLAT:0.15 ID X 0.375 INCH OD, STL ---*---	12327	OBD
-116	131-0804-00		1	.LINK, TERM.CONNE:J-SHAPE	80009	131-0804-00
-117	131-0805-00		2	.LINK, TERM.CONNE:J-SHAPE, 0.90X0.82 X 0.312"	80009	131-0805-00

REV. D JAN 1976

Mechanical Parts List--7623A/R7623A Service

Fig. & Index No.	Tektronix Part No.	Serial/Model No Eff Dscont	Qty	1 2 3 4 5 Name & Description	Mfr Code	Mfr Part Number
1-118	131-1003-00		2	.CONNECTOR BODY, CKT BD MT, 3 PRONG	80009	131-1003-00
-119	136-0252-01		2	.CONTACT, ELEC:0.178 INCH LONG	00779	1-332095-2
	131-0767-08		2	.CONNECTOR, RCPT, :PLUG-IN CKT BD, 70 CONTACT (ATTACHING PARTS FOR EACH)	80009	131-0767-08
-120	213-0232-00		2	.SCR, TPG, THD FOR:2-32 X 0.312 INCH, PNH STL83385 OBD		
	-----		-	..EACH CONNECTOR INCLUDES:		
-121	200-0950-00		2	..COVER, ELEC CONN:PLASTIC	80009	200-0950-00
-122	131-0726-00		33	..CONTACT, ELEC:STRAIG HT	80009	131-0726-00
-123	131-0727-00		33	..CONTACT, ELEC:OFFSET	80009	131-0727-00
-124	131-0899-00		4	..CONTACT, ELEC:0.048 X 0.006 INCH THK	80009	131-0899-00
-125	204-0365-00		1	..BODY, CONNECTOR:PLUG-IN CIRCUIT BOARD	80009	204-0365-00
	131-0767-07		1	.CONNECTOR, RPT, PLU-IN CBD, 70 CONTACT (ATTACHING PARTS)	80009	131-0767-07
-126	213-0232-00		2	.SCR, TPG, THD FOR:2-32 X 0.312 INCH, PNH STL	83385	OBD
	210-0906-00		1	.WASHER, NONMETAL:FIBER, 0.125 ID X 0.203"OD	86445	OBD
	-----		-	..CONNECTOR INCLUDES:		
-127	200-0950-00		2	..COVER, ELEC CONN:PLASTIC	80009	200-0950-00
-128	131-0726-00		35	..CONTACT, ELEC:STRAIGHT	80009	131-0726-00
-129	131-0727-00		35	..CONTACT, ELEC:OFFSET	80009	131-0727-00
-130	204-0365-02		1	..BODY CONNECTOR:PLUG-IN CIRCUIT BOARD	80009	204-0365-02
-131	-----		1	.CKT BOARD ASSY:VERT INTCON(SEE A15 EPL) (ATTACHING PARTS)		
-132	211-0008-00		2	.SCREW, MACHINE:4-40 X 0.25 INCH, PNH STL	83385	OBD
-133	351-0213-00		2	.GUIDE-POST, LOCK:0.285 INCH LONG	80009	351-0213-00
	-----		-	..CKT BOARD ASSY INCLUDES:		
-134	131-0787-00		8	..CONTACT, ELEC:0.64 INCH LONG	22526	47359
-135	344-0147-00		2	.CLIP, SPR, TNSN:CIRCUIT BOARDMOUNTIN (ATTACHING PARTS FOR EACH)	80009	344-0147-00
-136	210-0406-00		1	.NUT, PLAIN, HEX, 4-40 X 0.188 INCH, BRS	73743	2X12161-402
-137	210-0054-00		1	.WASHER, LOCK:SPLIT, 0.118 ID X 0.212"O STL	83385	OBD
	-----		-	..PIN, GUIDE:	80009	214-1568-00
-138	214-1568-00		1	.SPACER, CKT BD:PLASTIC	80009	386-1558-00
-139	386-1558-00		1	.TERM., TEST PTO.40 INCH LONG	80009	214-0579-00
-140	214-0579-00		1	.CKT BOARD ASSY:VERTICAL INTERFACE(SEE A4 EPL) (ATTACHING PARTS)		
-141	-----		1	.SCREW, MACHINE 4-40 X 0.25 INCH, PNH STL	83385	OBD
-142	211-0008-00		2	.SCREW, MACHINE 4-40 X 0.25 INCH, PNH STL	83385	OBD
	-----		-	..CKT BOARD ASSY INCLUDES:		
-143	136-0252-04	B010100 B010149	31	.CONTACT, ELEC:0.188 INCH LONG	22526	75060
	136-0252-04	B010150	22	.CONTACT, ELEC:0.188 INCH LONG	22526	75060
	136-0350-00	B010150	3	.SOCKET, PLUG-IN:3 PIN, LOW PROFILE	80009	136-0350-00
-144	136-0263-04		18	.CONTACT, ELEC:FOR 0.025 INCH SQUARE PIN	22526	75377-001
-145	-----		1	.CKT BOARD ASSY:TRIGGER SELECT(SEE A3 EPL) (ATTACHING PARTS)		
-146	211-0008-00		2	.SCREW, MACHINE:4-40 X 0.25 INCH, PNH STL	83385	OBD
	-----		-	..CKT BOARD ASSY INCLUDES:		
-147	131-0589-00		4	.CONTACT, ELEC:0.46 INCH LONG	22526	47350
-148	136-0252-04	B010100 B010149	15	.CONTACT, ELEC:0.188 INCH LONG	22526	75060
	136-0350-00	B010150	5	.SOCKET, PLUG-INS3 PIN, LOW PROFILE	80009	136-0350-00
-149	136-0260-01		1	.SOCKET, PLUG-IN:16 CONTACT, RECT SHAPE	71785	133-51-02-075
-150	136-0263-03		16	.CONTACT, ELEC:FOR 0.025 INCH SQUARE PIN	00779	86250-2
-151	200-0728-00		2	COV, HANDLE END:	80009	200-0728-00
	343-0006-00	XB060700	1	CLAMP, LOOP:0.50 INCH DIA, PLASTIC (ATTACHING PARTS)	95987	1-2-6B
	210-0457-00	XB060700	1	NUT, PLAIN, EXT W:6-32 X 0.312 NCH, STL	83385	OD80
	210-0863-00	XB060700	1	WSHR, LOOP, CLAMP:POR 0.50" W IDE CLAMP, STL	95987	C191
	211-0559-00	XB060700	1	.SCREW, MACHINE:6-32 X 0.312", 100 DEG, FLH STL	83385	OBD

REV. D APR 1975

Mechanical Parts List--7623A/R7623A Service

Fig. & Index No.	Tektronix Part No.	Serial/Model No Eff Dscont	Qty	1 2 3 4 5 Name & Description	Mfr Code	Mfr Part Number
1-152	367-0108-00		1	HANDLE, SCOPE: (ATTACHING PARTS)	80009	367-0108-00
-153	212-0597-00		4	SCREW, MACHINE:10-32 X 0.50 INCH, STL	80009	212-0597-00
-154	386-1624-00		2	PL, RET., HANDLE:	80009	386-1624-00
-155	358-0485-00		4	BUSHING, SLEEVE:0.196ID X 0.287OD X 0.13" L	80009	358-0485-00
-156	386-1283-03		2	PLATE, HDL MTG:PLASTIC ---*---	80009	386-1283-03
	426-1042-00		1	FRAME ASSEMBLY: - .FRAME ASSY INCLUDES:	80009	426-1042-00
-157	426-0741-06		1	.FRAME SECT, CAB.=FRONT80009 426-0741-06 (ATTACHING PARTS)		
-158	210-0782-00		8	.RIVET, SOLID:0.125 OD X 0.312"100 DEG FLH ---*---	12360	OBD
-159	426-0741-03		1	.FRAME SECT, CAB.:REAR (ATTACHING PARTS)	80009	426-0741-03
-160	210-0782-00		8	.RIVET, SOLID:0.125 OD X 0.312"100 DEG FLH ----*---	12360	OBD
-161	426-0753-00		1	.FRAME SECT, CAB.TOP CENTER	80009	426-0753-00
	343-0006-00	XB060700	1	.CLAMP, LOOP:0.50 INCH DIAMETER, PLSTC (ATTACHING PARTS)	95987	1-2-6B
	211-0559-00	XB060700	1	.SCREW, MACHINE:6-32 X 0.375"100 DEG, FLH STt	83385	OBD
	210-0863-00	XB060700	1	.WSHR, LOOP CLAMP:FOR 0.50" WIDE CLAMP, STL	95987	C191
	210-0457-00	XB060700	1	.NUT, PLAIN, EXT W:6-32 X 0.312 INCH, STL ----*---	83385	OBD
-162	380-0238-00		1	.HOUSING, PLUG-IN: (ATTACHING PARTS)	80009	380-0238-00
-163	210-0782-00		2	.RIVET, SOLID:0.125 OD X 0.312"100 DEG FLH ---*---	12360	OBD
-164	426-0857-00		1	.FRAME SECT, CAB.:LOWER RIGHT	80009	426-0857-00
-165	426-0858-00		1	.FRAE SECT, CAB.:LOWER LEFT	80009	426-0858-00

REV. E JULY 1976

Mechanical Parts List--7623A/R7623A Service

Fig. & Index No.	Tektronix Part No.	Serial/Model No Eff Dscont	Qty	1 2 3 4 5 Name & Description	Mfr Code	Mfr Part Number
2-1			1	CKT BOARD ASSY:VERTICAL AMP(SEE A5 EPL) (ATTACHING PARTS)		
-2	211-0008-00		3	SCREW, MACHINE:4-40 X 0.25 INCH, PNHM STL ---*---	83385	OBD
	-----			.CKT BOARD ASSY INCLUDES:		
-3	131-0566-00		4	.LINK, TERM.CONNE:0.086 DIA X 2.375 INCH L	0000C	L-2007-1
-4	131-0608-00		8	.CONTACT, ELEC:0.365 INCH LONG	22526	47357
-5	131-1003-00		3	.CONNECTOR BODY, :CKT BD MT, 3 PRONG	80009	131-1003-00
-6	136-0252-04	B010100 B010149	36	.CONTACT, ELEC:0.188 INCH LONG	22526	75060
	136-0350-00	B010150	9	.SOCKET, PLUG-IN:3 PIN, LOW PROFILE	80009	136-0350-00
-7	214-0579-00		2	.TERM., TEST PT:0.40 INCH LONG	80009	214-0579-00
-8	131-0775-00		2	.TERMINAL, STUD:6-32 X 0.25 X 0.375"LG (ATTACHING PARTS FOR EACH)	80009	131-0775-00
-9	211-0503-00		1	.SCREW, MACHINE:6-32 X 0.188 INC., PNH STL ---*---	83385	OBD
-10	346-0117-00		1	.STRAP, GROUNDING:	80009	346-0117-00
-11	-----		1	CKT BOARD ASSY:HORIZ AMPL(SEE A6 EPL) (ATTACHING PARTS)		
-12	211-0008-002		2	SCREW, MACHINE:4-40 X 0.25 INCH , PNH STL ---*---	83385	OBD
	-----		-	.CKT BOARD ASSY INCLUDES:		
-13	131-0608-00		23	.CONTACT, ELEC:0.365 INCH LONG	22526	47357
-14	131-1003-00		2	.CONNECTOR BODY, :CKT BD MT, 3 PRONG	80009	131-1003-00
-15	136-0252-04		26	.CONTACT, ELEC:0.188 INCH LONG	22526	75060
-16	136-0260-02		1	.SOCKET, PLUG-IN:16 CONTACT, LOW CLEARANCE	01295	C931602
-17	214-0579-00		1	.TERM., TEST PT:0.40 INCH LONG	80009	214-0579-00
-18	210-0627-00		2	RIVET, SOLID:0.042 DIA X 0.25 INCH, RDH	80009	210-0627-00
-19	343-0097-00		2	RTNR, TRANSISTOR:HEAT SINK (ATTACHING PARTS FOR EACH)	80009	343-0097-00
-20	210-0599-00		2	NUT, SLEEVE:4-40 X 0.391 INCH LONG	80009	210-0599-00
-21	214-0368-00		1	SPRING, HLCPS:0.24 DIA X 0.438 INCH LONG ---*---	80009	214-0368-00
-22	352-0062-00		2	HOLDER, HEAT SK:1.187 X 1.187 INCHES, PLSTC (ATTACHING PARTS FOR EACH)	80009	352-0062-00
-23	211-0008-00	2	1	SCREW, MKACHINE4-40 X 0.25 INCH, PNH STL	83385	OBD
-24	211-0012-00		2	SCREW, HAC HINE:4-40 X 0.375", PNH STL	83385	OBD
-25	210-0406-00		4	NUT, PLAIN, HEX.:4-40 X 0.188 INCH, BRS ---*---	73743	2X12161-402
-26	119-0368-00		1	DELAY LINE, ELEC: (ATTACHING PARTS)	80009	119-0368-00
-27	213-0034-00		2	SCR, TPG, THD CTG:4-40 X 0.188 INCH, PNH STL ----*---	83385	OBD
-28	351-0087-00		1	GUIDE, CKT CARD:4.75 INCH LONG, PLASTIC	80009	351-0087-00
-29	348-0031-00		1	GROHMET, PLASTIC:0.156 INCH DIA	80009	348-0031-00
-30	348-0064-00		1	GROMMET, PLASTIC:0.625 INCH DIA	80009	348-0064-00
-31	255-0334-00		FT	PLASTIC CHANNEL:12.75 INCHES LONG	80009	255-0334-00
-32	407-1001-00		1	BRKT, CRT SHLD:FRONT (ATTACHING PARTS)	80009	407-1001-00
	211-0589-00		2	SCREW, MACHINE:6-32 X 0.312 INCH, PNH BRS	83385	OBD
-33	210-0457-00		2	NUT, PLAIN, EXT W:6-32 X 0.312 INCH, STL	83385	OBD
-34	211-0538-00		2	SCREW, MACHINE:6-32 X 0.312"100 DEG, FLH STL ---*---	83385	OBD
-35	-----			CKT BOARD ASSY:STORAGE(SEE A14 EPL) (ATTACHING PARTS)		
-36	211-0008-00		2	SCREW, MACHINE:4-40 X 0.25 INCH, PNH STL	83385	OBD
-37	129-0236-00		2	POST, MEWTALLIC:4-40 X 0.188 K 0.375"LG	06540	9726-A-D440
-38	210-0586-00		2	NUT, PLAIN, EXT W:4-40 X 0.25 INCH, STL ---*---	78189	OBD
	-----		-	.CKT BOARD ASSY INCLUDES:		
-39	131-0608-00	B010100 B129999	98	.CONTACT, ELEC:0.365 INCH LONG	22526	47357
	131-0608-00	B130000	111	.CONTACT, ELEC:0.365 INCH LONG	22526	47357
-40	136-0252-04	B010100 B010149	201	.CONTACT, ELEC:0.188 INCH LONG	22526	75060
	136-0252-04	B010150	112	.CONTACT, ELEC:0.188 INCH LONG	22526	75060
	136-0350-00	B010150 B129999X	63	.SOCKET, PLUG-IN:3 PIN, LOW PROFILE	80009	136-0350-00
-41	136-0260-02		3	.SOCKET, PLUG-IN:16 CONTACT, LOW CLEARANCE	01295	C931602

REV. D JULY 1976

Mechanical Parts List--7623A/R7623A Service

Fig. & Index No.	Tektronix Part No.	Serial/Model No		Qty	1 2 3 4 5 Name & Description	Mfr Code	Mfr Part Number
		Eff	Dscont				
2-42	136-0269-02			4	.SOCKET, PLUG-IN:14 CONTACT, LOW CLEARANCE	01295	C931402
-43	214-0579-00			8	.TERM., TEST PT 0.40 INCH LONG	80009	214-0579-00
	131-0993-00	XB050000	B129999	1	.LINK, TERM.CONNE:JUMPER	00779	530153-2
	131-0993-00			B130000	2	.LINK, TERM CONNE:JUMPER	00779
-44	260-1378-00			1	.SWITCH, PUSH:VERT MODE	71590	2KBC140000-608
-45	366-1402-02			1	.PUSH BUTTON: LEFT	80009	366-1402-02
-46	366-1402-03			1	.PUSH BUTTON:ALT	80009	366-1402-03
-47	366-1402-04			1	.PUSH BUTTON:ADD	80009	366-1402-04
-48	366-1257-31			1	.PUSH BUTTON:CHOP	80009	366-1257-31
-49	366-1402-06			1	.PUSH BUTTON:RIGHT	80009	366-1402-06
-50	260-1379-00			1	.SWITCH, PUSH:TRIG SOURCE	71590	2KBC120000-595
-51	366-1402-02			1	.PUSH BUTTON:LEFT	80009	366-1402-02
-52	366-1402-07			1	.PUSH BUTTON:VERT MODE	80009	366-1402-07
-53	366-1402-06			1	.PUSH BUTTON:RIGHT	80009	366-1402-06
-54	260-1594-00			1	.SWITCH PUSH:NON STORE/STORE/SAVE		OBD
-55	366-1402-08			1	.PUSH BUTT ON:NONSTORE	80009	366-1402-08
-56	366-1257-85			1	.PUSH BUTTON:GRAY--STORE	80009	366-1257-85
-57	366-1402-21			1	.PUSH BUTTON:SAVE	80009	366-1402-21
-58	361-0411-00			15	.SPACER, PUSH SW:0.13 W X 0.375 INCH L, PLSTC	71590	J64285-00
-59	384-1099-00			5	.EXTENSION SHAFTPUSH BUTTON, 1.54 INCH LONG	80009	384-1099-00
-60	384-1136-00			6	.EXTENSION SHAFT 0.95 INCH LONG	80009	384-1136-00
-61	352-0019-00			2	.HOLDER:PLASTIC (ATTACHING PARTS FOR EACH)	80009	352-0019-00
-62	213-0088-00			1	.SCR, TPG, THD CTG:4-24 X 0.25 INCH, PNH STL ---*---	83385	OBD
	200-1799-00	XB080985		1	COVER, PROT: (ATTACHING PARTS)	80009	200-1799-00
	211-0008-00			1	SCREW, MACHINE:4-40 X 0.25 INCH, PNH STL	83385	OBD
	210-0801-00			1	WASHER, FLAT:0.14 ID X 0.281 OD UP STL ---*---	12327	OBD
-63	407-1397-00			1	BRACKET, ANGLE (ATTACHING PARTS)	80009	407-1397-00
-64	211-0147-00			2	SCREW, MACHINE 4-40 X 0.25 INCH, PNH STL	83385	OBD
-65	210-0586-00			2	NUT, PLAIN, EXT W:4-40 X 0.25 INCH, STL ---*---	78189	OBD
-66	386-2416-00			1	SUPPORT, CHASSIS (ATTACHING PARTS)	80009	386-2416-00
-67	211-0511-00			1	SCREW, MACHINE:6-32 X 0.50 INCH, PNH STL	83385	OBD
-68	210-0993-00			1	WSHR, SHOULDERED 0 143" ID X 0.75" OD, BRS	79807	OBD
	211-0510-00			2	SCREW, MACHINE6-32 X 0.375 INCH, PNE STL	83385	OBD
	210-0457-00			2	NUT, PLAIN, EXT W:6-32 X 0.312 INCH, STL ---*---	83385	OBD
	343-0213-00	XB070000		1	CLAMP, LOOP:PRESS MT, PLASTIC	80009	343-0213-00
-69	407-1002-00			1	BRACKET, CHASSIS (ATTACHING PARTS)	80009	407-1002-00
	211-0508-00			4	SCREW, MACHINE:6-32 X 0.312"100 DEG, FLH STL	83385	OBD
	210-0457-00			4	NUT, PLAIN, EXT W:6-32 X 0.312 INCH, STL	83385	OBD
-70	211-0511-00			1	SCREW, MACHINE:6-32 X 0.50 INCH, PNE STL	83385	OBD
-71	210-0993-00			1	WSHR, SHOULDERED:0.143" ID X 0.75" OD, BRS ---*---	79807	OBD
	672-0572-00	XB120000		1	CKT BOARD ASSY:PROTECTION AND READOUT	80009	672-0572-00
-72	-----			1	.CKT BOARD ASSY PROTECTION(SEE A18 EPL)		
-73	131-0589-00	XB120000		20	.CONTACT, ELEC.0.46 INCH LONG	22526	47350
-74	253-0162-00			FT	.TAPE, PRESS SENS.0.062 X 0.125 X 0.2 08' L	04963	OBD
-75	210-0702-00	XB120000		2	.EYELET, METALLIC0.047 OD X 0.125 INCH LONG	07707	S6127
-76	-----			1	.CKT BOARD ASSY.READOUT(SEE A13 EPL) (ATTACHING PARTS)		
-77	211-0008-00			1	.SCREW, MACHINE:4-40 X 0.25 INCH, PNH STL ---*---	83385	OBD
	-----			-	.CKT BOARD ASSY INCLUDES:		
-78	131-0608-00			40	.CONTACT, ELEC0.365 INCH LONG	22526	47357
-79	131-1003-00			6	.CONNECTOR BODYCKT BOARD MT, 3 PRONG	80009	131-1003-00
-80	136-0235-00			1	.SOCKET, PLUG-IN 6 CONTACT, ROUND	71785	133-96-12-062
-81	136-0252-01			6	.CONTACT, ELEC'0.178 INCH LONG	00779	1-332095-2

REV. E JULY 1976

Mechanical Parts List--7623A/R7623A Service

Fig. & Index No.	Tektronix Part No.	Serial/Model No Eff Dscont	Qty	1 2 3 4 5 Name & Description	Mfr Code	Mfr Part Number
2-	136-0252-04		39	..CONTACT, ELEC:0.188 INCH LONG	22526	75060
-82	136-0260-02		14	..SOCKET, PLUG-IN:16 CONTACT, LOW CLEARANCE	01295	C931602
-83	136-0269-02		3	..SOCKET, PLUG-IN:14 CONTACT, LOW CLEARANCE	01295	C931402
-84	260-0723-00		1	..SWITCH, SLIDE:DPDT, 0.5A, 125VAC	79727 GF126-0028	
-85	214-0579-00	B010100 B111999	21	..TERM., TEST PT:0.40 INCH LONG	80009	214-0579-00
	214-0579-00	8I20000	20	..TERM, TEST PT:0.40 INCH LONG	80009	214-0579-00
-86	195-0114-08		1	LEAD SET:READOUT	80009	195-0114-08
	621-0474-01		1	POWER SUPPLY:HIGH VOLTAGE (ATTACHING PARTS)	80009	621-0474-01
-87	211-0504-00		4	SCREW, MACHINE:6-32 X 0.25 INCH, PNH STL ---*---	83385	OBD
	-----		-	..HIGH VOLTAGE INCLUDES:		
-88	351-0324-00		2	..GUIDE, CKT CARD:	80009	351-0324-00
-89	-----		1	..CKT BOARD ASSY:Z AXIS(SEE A8 EPL) (ATTACHING PARTS)		
-90	211-0008-00		3	..SCREW, MACHINE:4-40 X 0.25 INCH, PNH STL ---*---	83385	OBD
	-----		-	..CKT BOAR D ASSY INCLUDES:		
-91	131-0608-00		52	..CONTACT, ELEC:0.365 INCH LONG	22526	47357
-92	131-1003-00		3	..CONNECTOR BODY, :CKT ED MT, 3 PRONG	80009	131-1003-00
-93	136-0252-04		45	..CONTACT, ELEC:0.188 INCH LONG	22526	75060
	131-0566-00	XB20000	1	..LINK, TERM.CONNNE:0.086 DIA X 2.375 INCH L	0000C	L-2007-1
-94	-----		1	..CKT BOARD ASSY:ANODE(SEE A9 EPL) (ATTACHING PARTS)		
-95	211-0040-00		3	..SCREW, MACHINE:4-40 X 0.25", BDCH PLSTC	26365	OBD
-96	211-0008-00		1	..SCREW, MACHINE:4-40 X 0.25 INCH, PNH STL	83385	OBD
-97	-----		1	..CKT BOARD ASSY:HIGH VOLTAGE(SEE A10 EPL) (ATTACHING PARTS)		
-98	211-0008-00		2	..SCREW, MACHINE:4-40 X 0.25 INCH, PNH STL	83385	OBD
-99	211-0040-00		1	..SCREW, MACHINE:4-40 X 0.25", BDCH PLSTC ---*---	26365	OBD
	-----		-	..CKT BOARD ASSY INCLUDES:		
-100	124-0118-00		1	..TERMINAL BOARD.1 NOTCH (ATTACHING PARTS)	80009	124-0118-00
-101	361-0007-00		1	..SPACER, SLEEVE:0.250 INCH DIA, PLASTIC ---*---	80009	361-0007-00
	-----		-	...TERMINAL STRIP INCLUDES:		
-102	355-0046-00		1	..MOUNT, TERM.BD:0.577 INCH	80009	355-0046-00
-103	124-0119-00		1	..TERMINAL BOARD2 NOTCH (ATTACHING PARTS)	80009	124-0119-00
-104	361-0007-00		1	..SPACER, SLEEVE 0.250 INCH DIA, PLASTIC ---*---	80009	361-0007-00
	-----		-	...TERMINAL STRIP INCLUDES:		
-105	355-0046-00		1	..MOUNT, TERM.BD:0.577 INCH	80009	355-0046-00
-106	131-0589-00		7	..CONTACT, ELEC:0.46 INCH LONG	22526	47350
	131-0608-00		21	..CONTACT, ELEC0.365 INCH LONG	22526	47357
-107	136-0252-04		9	..CONTACT, ELEC :0.188 INCH LONG	22526	75060
-108	166-0292-00		2	..SPACER, SLEEVE:PLSTC, 0.155 DIA X 0.065"L	80009	166-0292-00
-109	214-0579-00		1	..TERM., TEST PT:0.40 INCH LONG	80009	214-0579-00
-110	-----		1	..TRANSISTOR: (ATTACHING PARTS)		
-111	213-0146-00		2	..SCR, TPG, THD FORs6-20 X 0.313 INCH, PNH STL	83385	OBD
-112	386-0978-00		1	..INSULATOR, PLATE:0.002 INCH MICA, FOR TO-3 ---*---	80009	386-0978-00
-113	136-0280-00		1	..SOCKET, PLUG-IN:FOR TO-3 (ATTACHING PARTS)	22753	PTS1
-114	211-0101-00		2	..SCREW, MACHINE:4-40 X 0.25" 100 DEG, FLE STL	83385	OBD
-115	210-0586-00		2	..NUT, PLAIN, EXT W:4-40 X 0.25 INCH, STL ---*---	78189	OBD
-116	348-0063-00		1	..GROMMET, PLASTIC:0.50 INCH DIA	80009	348-0063-00
-117	343-0088-00		1	..CLAMP, LOOP:0.062 INCH DIA	80009	343-0088-00

REV. E JAN 1976

Mechanical Parts List--7623A/R7623A Service

Fig. & Index No.	Tektronix Part No.	Serial/Model No Eff Dscnt	Qty	1 2 3 4 5 Name & Description	Mfr Code	Mfr Part Number
2-118	348-0085-00	B010100 B099999	FT	PLASTIC CHAE:12.75 INCHES LONG	80009	255-0334-00
	358-0166-00	B100000	1	.GROET, PLASTIC:U-SHAPED	80009	358-0166-00
-119	129-0251-01		1	.POST, NONMETALLI:4-40 X 0.25 OD X 1.125"L (ATTACHING PARTS)	80009	129-0251-01
-120	129-0236-00			.POST, METALLIC:4-40 X 0.188 X 0.375" LG	06540	9726-A-D440
	211-0008-00		1	.SCREW, MACHINE:4-40 X 0.25 INCH, PNH STL	83385	OBD
	210-0004-00		2	.WASHER, LOCK:INTL, O.12 ID X 0.26"OC, STL ---*---	78189	1204-00-00-0541C
-121	129-0251-00		3	.POST, NONMETALLI:-40 X 0.25 ODX1.125"LONG (ATTACHING PARTS FOR EACH)	80009	129-0251-00
-122	211-0040-00		1	.SCREW, MACHINE:4-40 X 0.25", BDCH PLSTC	26365	OBD
-123	129-0143-00		3	.INSULATOR, STDF:0.31OD X 0.406" L, NYLON (ATTACHING PARTS FOR EACH)	80009	129-0143-00
-124	211-0008-00		1	.SCREW, MACHINE:4-40 X 0.25 INCH, PNH STL ---*---	83385	OBD
-125	131-0773-00		1	.CONN, RCPT, ELEC:	01009	8111
-126	337-1538-01		1	.SHIELD, ELEC:HIGH VOLTAGE	80009	337-1538-01
-127	441-1192-00		1	CHASSIS, SCOPE: AIN (ATTACHING PARTS)	80009	441-1192-00
-128	211-0590-00		2	SCREW, MACHINE:6-32 X 0.25 INCH, PNH STL	83385	OBD
-129	210-0457-00		2	NUT, PLAIN, EXT W 6-32 X 0.312 INCH, STL ---*---	83385	OBD
	-----		1	.CHASSIS INCLUDES		
-130	354-0347-00		1	.RING, CLP, CRT RE: (ATTACHING PARTS)	80009	354-0347-00
-131	211-0507-00		4	.SCREW, MACHINE:6-32 X 0.312 INCH, PNH TL ---*---	83385	OBD
-132	343-0205-01		1	.RTNR, ELECTRON T: (ATTACHING PARTS)	80009	343-0205-01
-133	211-0170-00		2	.SCREW, MACHINE:4-40 X 2.75 INCH, PNH STL	83385	OBD
-134	214-1333-00		2	.SPRING, HLCPS.0.213 OD X 0.375 INCH LONG ---*---	80009	214-1333-00
	210-0803-00	XB070000	1	WASHER, FLAT 0.15 ID X 0.375 INCH OD, STL	12327	OBD
	343-0004-00	XB070000	1	CLAMP, LOOP.0.312 INCH DIAMETER, PLSTC	95987	5-16-6B
-135	-----		1	COIL (ATTACHING PARTS)		
-136	213-0138-00		2	SCR, TPG, THD FOR.4-40 X 0.188 INCH, PNH STL	83385	OBD
-137	343-0217-00		1	CLAMP, COIL: ---*---	80009	343-0217-00
	342-0182-00		1	INSULATOR:CRT SHIELD	80009	342-0182-00
-136	342-0184-00		1	INSULATOR.CRT FRONT	80009	342-0184-00
-139	337-1531-00		1	SHIELD, CRT:	80009	337-1531-00
-140	337-1757-00		1	SHIELD, ELEC:REGULATOR (ATTACHING PARTS)	80009	337-1757-00
-141	211-0097-00		4	SCREW, MACHINE:4-40 X 0.312 INCH, PNH STL ---*---	83385	OBD
-142	441-1129-00		1	CHASSIS, SCOPE. (ATTACHING PARTS)	80009	441-1129-00
	211-0509-00		4	SCREW, MACHINE:6-32 X 0.375"100 DEG, FLH STL ---*---	83385	OBD
-143	147-0008-00		1	MOTOR AC BARBER COLMAN (ATTACHING PARTS)	05624	AYAA13080
-144	212-0557-00		2	SCREW, MACHINE:10-32 X 0.50 INCH, RND H STL	83385	OBD
-145	337-1756-00		1	SHIELD, ELEC FAN	80009	337-1756-00
-146	210-1112-00		2	WASHER, FLAT:0.228 ID X 0.375 INCH OD, PLSTC ---*---	80009	210-1112-00
-147	369-0037-00		1	FAN BLADE:PLASTIC	52792	3500CW125N
-148	378-0811-00		1	BAFFLE, AIR: (ATTACHING PARTS)	80009	378-0811-00
-149	211-0008-00		4	SCREW, MACHINE:4-40 X 0.25 INCH, PEH STL ---*---	83385	OBD

Mechanical Parts List--7623A/R7623A Service

Fig. & Index No.	Tektronix Part No.	Serial/Model No Eff Dscnt	Qty	1 2 3 4 5 Name & Description	Mfr Code	Mfr Part Number
2-150	-----		6	TRANSISTOR: (ATTACHING PARTS FOR EACH)		
-151	211-0511-00	B01010 B091389	2	SCREW, MACHINE:6-32 X 0.50 INCH, PNH STL	83385	OBD
	211-0578-00	B091390	2	SCREW, MACHINE:6-32 X 0.438 INCH, PNH STL	83385	OBD
-152	386-0978-00		1	INSULATOR, PLATE:0.002 INCH MICA, FOR TO-3 ---*---	80009	386-0978-00
	343-0004-00	XB070000	1	CLAMP, LOOP:0.312 INCH DIAMETER, PLSTC (ATTACHING PARTS)	95987	5-16-6B
	210-0457-00	XB070000	1	NUT, PLAIN, EXT W:6-32 X 0.312 INCH, STL	83385	OBD
	210-0803-00	XB070000	1	WASHER, FLAT:0.15 ID X 0.375 INCH OD, STL ---*---	12327	OBD
-153	-----		1	CKT BOARD ASSY:REGULATOR(SEE A12 EPL)		
	-----		-	.CKT BOAR D ASSY INCLUDES:		
-154	131-0608-00		49	.CONTACT, ELEC:0.365 INCH LONG	22526	47357
-155	136-0183-00		3	.SOCKET, PLUG-IN:3 PIN	80009	136-0183-00
-156	136-0235-00		6	.SOCKET, PLUG-IN:6 CONTACT, ROUND	71785	133-96-12-062
-157	131-0847-00		12	.TERMINAL STUD:6-32 X 0.435 INCH LONG	80009	131-0847-00
-158	136-0361-00		6	.SOCKET, PLUG-IN:	80009	136-0361-00
-159	136-0384-00		12	.CONTACT, ELEC:FOR 0.04 DIAMETER PIN	00779	52120
-160	136-0252-04	B010100 B010149	36	.CONTACT, ELEC:0.188 INCH LONG	22526	75060
	136-0252-04	B010150	12	.CONTACT, ELEC:0.188 INCH LONG	22526	75060
	136-0350-00	BO10150	9	.SOCKET, PLUG-IN:3 PIN, LOW PROFILE	80009	136-0350-00
-161	136-0269-02		1	.SOCKET, PLUG-IN:14 CONTACT, LOW CLEARANCE	01295	C931402
-162	214-0579-00		1	.TERM., TEST PT:0.40 INCH LONG	80009	214-0579-00
-163	214-1291-00		3	.HEAT SINK, ELEC:ST, 0.72 OD X 0.375"H	05820	207-AB
-164	344-0154-00		2	.CLIP, ELECTRICAL:FOR 0.25 INCH DIA FUSE	80009	344-0154-00
	614-0104-01		1	SUBPANEL ASSY:REAR (ATTACHING PARTS)	80009	614-0104-01
-165	211-0529-00		4	SCREW, MACHINE:6-32 X 1.25 INCHES, PNH STL	83385	OBD
-166	348-0191-00		4	LEG, ELEC EQUIP.:PLASTIC	80009	348-0191-00
-167	211-0008-00		1	SCREW, MACHINE:4-40 X 0.25 INCH, PNH STL ---*---	83385	OBD
	-----		-	.SUBPANEL ASSY INCLUDES:		
-168	161-0033-09		1	.CABLE ASSY, PWR:3 WIRE, 92 INCH LONG	16428	KH8035
-169	358-0323-00		1	.BSHG, STRAIN RLF:90 DEG, 0.515 DIA HOLE	28520	SR15-1
-170	200-1388-00	B010100I B091389	1	.COVER, FUSE:	80009	200-1388-00
	200-1388-01	B091390	1	.COVER, FUSE:		
-171	352-0076-00		1	.FUSEHOLDER:W/HARDWARE	75915	342012
-172	131-0955-00		6	.CONNECTOR, RCPT, .BNC, FEMALE (ATTACHING PARTS FOR EACH)	24931	28JR200-1
-173	210-0255-00		1	.TERMINAL, LUG:0.391 ID INT TOOTH ---*---	80009	210-0255-00
-174	210-0204-00		1	.TERMINAL, LUG:0.146 INCH DIA DE, 45 DEG BEND (ATTACHING PARTS)	78189	2157-06-01-2520N
-175	211-0504-00		1	.SCREW, ACHINE:6-32 X 0.25 INCH, PNH STL	83385	OBD
-176	210-0407-00		1	.NUT, PLAIN, HEX.:6-32 X 0.25 INCH, BRS ---*---	73743	3038-0228-402
-177	-----		-	.CKT BOARD ASSY:OUTPUT SIGNALS(SEE A7 EPL) (ATTACHING PARTS)		
-178	211-0008-00		2	.SCREW, MACHINE:4-40 X 0.25 INCH, PNH STL ---*---	83385	OBD
	-----		-	.CKT BOARD ASSY INCLUDES:		
-179	131-0608-00		10	.CONTACT, ELEC:0.365 INCH LONG	22526	47357
-180	131-1003-00		2	.CONNECTOR BODY, CKT BD MT, 3 PRONG	80009	131-1003-00
-181	136-0252-01		2	.CONTACT, ELEC:0.178 INCH LONG	00779	1-332095-2
	136-0252-04	B010100 B010149	27	.CONTACT, ELEC:0.188 INCH LONG	22526	75060
	136-0350-00	B010150	9	.SOCKET, PLUG-IN:3 PIN, LOW PROFILE	80009	136-0350-00
-182	214-0579-00		1	.TERM., TEST PT:0.40 INCH LONG	80009	214-0579-00
-183	260-0984-00		1	.SWITCH, SLIDE :DP3POSN, 0.5A, 125VAC-DC	79727	G-128SPC/7140
-184	386-2199-00		1	.PANEL, REAR:POWER	80009	386-2199-00
-185	179-1091-00		1	.CABLE, SP, ELEC:	80009	179-1091-00

REV. E JAN 1976

Mechanical Parts List--7623A/R7623A Service

Fig. & Index No.	Tektronix Part No.	Serial/Model No Eff Dscont	Qty	1 2 3 4 5 Name & Description	Mfr Code	Mfr Part Number
2-	343-0003-00	XB070000	1	CLAMP, LOOP:0.25 INCH DIA	95987	1-4 6R
	211-0012-00	XB070000	1	(ATTACHING PARTS)		
	210-0803-00	XB070000	1	SCREW, MACHINE-4-40 X 0.375 INCH, PNH STL	83385	OBD
	210-0586-00	XB070000	1	WASHER, FLAT:0.15 ID X 0.375 INCH OD, STL	12327	OBD
			1	NUT, PLAIN, EXT W:4-40 X 0.25 INCH, STL	78189	OBO
				---*---		
	614-0077-05		1	POWER SUPPLY:LOW VOLTAGE	80009	614-0077-05
				(ATTACHING PARTS)		
	212-0040-00		6	SCREW, MACHINE 8-32 X 0.375 100 DEG, FLH STL	83385	OBD
				---*---		
				.POWER SUPPLY INCLUDES:		
				.CKT BOARD ASSY:RECTIFIER(SEE ALL EPL)		
				(ATTACHING PARTS)		
-186				---*---		
-187	21-0511-002			SCREW, MACHINE:6-32 X 0.50 INCH, PNH STL	83385	OBD
-188	210-0863-00			.WSHR, LOOP CLAMP:FOR 0.50" WIDE CLAMP, STL	95987	C191
-189	343-0004-00		1	.CLAMP, LOOP:0.312 INCH DIAETER, PLSTC	95987	5-16-6B
-190	211-0507-00		2	SCREW, MACHINE:6-32 X 0.312 INCH, PNH STL	83385	OBD
-191	210-0202-00		1	.TERMINAL, LUG:SE #6	78189	2104-06-00-2520N
				---*---		
				..CKT BOARD ASSY INCLUDES:		
-192	131-0608-00		31	.CONTACT, ELEC:0.365 INCH LONG	22526	47357
-193	136-0252-01	B010100 B 010149	6	.CONTACT, ELEC:0.178 INCH LONG	00779	1-332095-2
	136-0350-00	B010150	2	.SOCKET, PLUG-IN:3 PIN, LOW PROFILE	80009	136-0350-00
-194	214-1731-01		1	.HEAT SINK, ELEC:TRANSISTOR	80009	214-1731-01
				(ATTACHING PARTS)		
-195	211-0012-00	B010100 B142324	1	SCREW, MACHINE:4-40 X 0.375 INCH, PNH STL	83385	OBD
	211-0016-00	B142325	1	SCREW, MACHINE:4-40 X 0.625 INCH, PNH STL	83385	OBD
	210-0851-00	XB142325	1	WASHER, FLAT:0.119 ID X 0.375 INCH OD, STL	12327	OBD
-196	210-0935-00		1	WASHER, NOETAL:FIBER, 0.14 ID X 0.375"OD	74921	OBD
-197	210-0586-00		1	NUT, PLAIN, EXT W:4-40 X 0.25 INCH, STL	78189	OBD
				---*---		
	407-1837-00	XB142325	1	.BRACKET, CKT CRD	80009	407-1837-00
				(ATTACHING PARTS)		
	212-0522-00	XB142325	1	SCREW, MACHINE:10-32 X 2.50", HEX HD, STL	83385	OBD
	210-0805-00	XB142325	1	WASHER, FLAT:0.204 ID X 0.438 INCH OD, STL	12327	OBD
	166-0457-00	XB142325	2	INSUL SLVG, ELEC:0.19 ID X 1.875"LONG YLAR	80009	166-0457-00
	220-0410-00	XB142325	1	NUT, EXTENDED WA.10-32 X 0.375 INCH, STL	83385	OBD
				---*---		
-198	214-292-00		2	.HEAT SINK, ELEC:TRANSISTOR	05820	205-AB
-199	344-0154-00		4	.CLIP, ELECTRICAL:FOR 0.25 INCH DIA FUSE	80009	344-0154-00
-200				.SW, THERMOSTATIC: (SEE S1000 EPL)		
				(ATTACHING PARTS)		
-201	211-0008-00		2	SCREW, MACHINE 4-40 X 0.25 INCH, PNH STL	83385	OBD
-202	210-058-000		2	NUT, PLAIN, EXT W:4-40 X 0.25 INCH, STL	78189	OBD
				---*---		
-203			1	.TRANSFORMER (SEE T801 EPL)		
				(ATTACHING PARTS)		
-204	212-0522-00		2	SCREW, MACHINE:10-32 X 2.50", HEX HD STL	83385	OBD
-205	210-0812-00		2	WASHER, NOETAL: #10, FIBER	86445	OBD
-206	166-0457-00		2	INSUL SLVG, ELEC:0.19 ID X 1.875"LONG MYLAR	80009	166-0457-00
-207	212-0023-00		2	SCREW, MACHINE-8-32 X 0.375 INCH, PNE STL	83385	OBD
-208	210-0804-00		2	WASHER, FLAT:0.17 ID X 0.375 INCH OD, STL	12327	OBD
-209	407-0921-00		1	.BRKT, XFR MTG	80009	407-0921-00
				---*---		
-210	441-0993-01		1	.CHASSIS, SCOPE:POWER SUPPLY, LOW VOLTAGE	80009	441-0993-01
-211	136-0617-00		1	CRT SOCKET ASSEMBLY:	80009	136-0617-00
-212	136-0304-02		1	.SOCKET, PLUG-IN CRT, 14 PIN SOCKET, W/PINS	80009	136-0304-02
-213	200-0917-01		1	.COV, ELECTRON TU 2.052 OD X 0.291" TK, PLSTC	80009	200-0917-01
-214	367-0117-00		1	.PULL, SOC, PL-IN:	80009	367-0117-00
-215	343-0254-00		1	.CLAMP, CRT SKT:	80009	343-0254-00
-216	131-0707-00		7	.CONTACT, ELEC:0.48"L, 22-26 AWG WIRE	22526	47439
-217	131-0621-00		6	.CONTACT, ELEC:0.577"L, 22-26 AWG WIRE	22526	46231
-218	348-0012-00		1	.GROMET, RUBBER-0.625 INCH DIA	72653	1043-MN
-219	352-0161-05		1	.CONN BODY, PL, EL:3 WIRE GREEN	80009	352-0161-05
-220	352-0162-09		1	.CONN BODY, PL, EL:4 WIRE WHITE	80009	352-0162-09
-221	352-0205-00		1	.CONN BODY, PL, EL:9 WIRE BLACK	80009	352-0205-00
-222	179-1825-00		1	WIRNG HARNESS, :VERTICAL SIGNAL	80009	179-1825-00
	131-0707-00		2	.CONTACT, ELEC:0.48"L, 22-26 AWG WIRE	22526	47439
	131-0708-00		2	.CONTACT, ELEC:0.48"L, 28-32 AWG WIRE	22526	47437
-223	210-0774-00		2	.EYELET, ETALLIC:0.152 OD X 0.245 INCH L, BS	80009	210-0774-00
-224	210-0775-00		2	.EYELET, ETALLIC:0.126 OD X 0.23 INCH L, BRS	80009	210-0775-00

Mechanical Parts List--7623A/R7623A Service

Fig. & Index No.	Tektronix Part No.	Serial/Model No Eff Dscont	Qty	1 2 3 4 5 Name & Description	Mfr Code	Mfr Part Number
2-	352-0162-09		1	.HOLDER, TERM, CON:3 WIRE, GREEN	80009	352-0162-09
	179-1826-00		1	WIRING HARNESS.SWEEP GATE	80009	179-1826-00
	131-0707-00		8	.CONTACT, ELEC .048"L, 22-26 AWG WIRE	22526	47439
	131-0708-00		8	.CONTACT, ELEC 0.48"L, 28-32 AWG WIRE	22526	47437
-225	352-0166-03		1	.CONN BODY, PL, EL:8 WIRE ORANGE	80009	352-0166-03
	179-1828-00		1	WIRING BARNNESS:RESET	80009	179-1828-00
	131-0707-00		2	.CONTACT, ELEC:0.48"L, 22-26 AWG WIRE	22526	47439
	131-0708-00		2	.CONTACT, ELEC:0.48"L, 28-32 AWG WIRE	22526	47437
-226	352-0169-05		1	.CONN BODY, PL, EL 2 WIRE, GREEN	80009	352-0169-05
	352-0169-09		1	.CONN BODY, PL, EL:2 WIRE WHITE	80009	352-0169-09
	131-0621-00		6	CONTACT, ELEC:0.577"L, 22-26 AWG WIRE	22526	46231
	131-0707-00		373	CONTACT, ELEC:0.48"L, 22-26 AWG WIRE	22526	47439
	131-0708-00		25	CONTACT, ELEC0.48"L, 28-32 AWG WIRE	22526	47437
-227	131-0361-00		4	CONTACT, ELEC QUICK DISCONNECT	00779	42617-2
-228	131-1538-00		4	CONTACT, ELEC.CRIMP-ON, 22-26 AWG WIRE	22526	75369-002
	210-0774-00		13	EYELET, METALLIC:0.152 OD X 0.245 INCH L, BRS	80009	210-00774-00
	210-0775-00		13	EYELET, METALLIC-0.126 OD X 0.23 INCH L, BRS	80009	210-0775-00
-229	175-0825-00		FT	WIRE, ELECTRICAL:2 WIRE RIBBON	23499	TEK-175-0825-00
-230	175-0826-00		FT	WIRE, ELECTRICAL:3 WIRE RIBBON	08261	TEK-175-0826-00
-231	175-0827-00		FT	WIRE, ELECTRICAL:4 WIRE RIBBON	08261	TEK-175-0827-00
-232	175-0828-00		FT	WIRE, ELECTRICAL:5 WIRE RIBBON	23499	TEK-175-0828-00
-233	175-0830-00		FT	WIRE, ELECTRICAL:7 WIRE RIBBON	08261	TEK-175-0830-00
-234	175-0831-00		FT	WIRE, ELECTRICAL:8 WIRE RIBBON	08261	TEK-175-0831-00
	175-0857-00		FT	WIRE ELECTRICAL:8 WIRE RIBBON	80009	175-0857-00
-235	175-0832-00		FT	WIRE, ELECTRICAL:9 WIRE RIBBON	23499	TEK-175-0832-00
-236	175-0833-00		FT	WIRE, ELECTRICAL:10 WIRE RIBBON	23499	TEK-175-0833-00
	175-0855-00		FT	WIRE ELECTRICAL:10 WIRE RIBBON	23499	TEK-175-0855-00
	352-0161-00		3	CONN BODY, PL, EL:3 WIRE BLACK	80009	352-0161-00
	352-0161-02		1	HOLDER, TERM, CON:3 WIRE, RED	80009	352-0161-02
	352-0161-03		1	CONN BODY, PL, EL:3 WIRE ORANGE	80009	352-0161-03
	352-0161-05		1	CONN BODY, PL, EL:3 WIRE GREEN	80009	352-0161-05
	352-0161-06		2	CONN BODY, PL, EL:3 WIRE BLUE	80009	352-0161-05
	352-0161-08		1	CONN BODY, PL, EL:3 WIRE GRAY	80009	352-0161-08
	352-0161-09		2	HOLDER, TERM, CON 3 WIRE, WHITE	80009	352-0161-09
	352-0162-00		3	CONN BODY, PL, EL:4 WIRE ORANGE 4 WIRE BLACK	80009	352-0162-00
	352-0162-01		4	CONN BODY, PL, EL:4 WIRE BROWN	80009	352-0162-01
	352-0162-05		2	CONN BODY, PL, EL 4 WIRE GREEN	80009	352-0162-05
	352-0162-09		2	HOLDER, TERM, CON:4 WIRE, WHITE	80009	352-0162-09
-237	352-0163-00		1	CONN BODY, PL, EL:5 WIRE BLACK	80009	352-0163-00
	352-0163-01		2	CONN BODY, PL, EL:5 WIRE BROWN	80009	352-0163-01
	352-0163-03		1	CONN BODY, PL, EL:5 WIRE ORANGE	80009	352-0163-03
	352-0163-05		3	CONN BODY, PL, EL:5 WIRE GREEN	80009	352-0163-05
	352-0163-06		2	CONN BODY, PL, EL:5 WIRE BLUE	80009	352-0163-06
	352-0163-08		4	CONN BODY, PL, ELS WIRE GRAY	80009	352-0163-08
-238	352-0164-01		1	CONN BODY, PL, EL:6 WIRE BROWN	80009	352-0164-01
	352-0164-09		1	HOLDER, TERM, CON:6 WIRE, WHITE	80009	352-0164-09
	352-0166-00		2	CONN BODY, PL, EL:8 WIRE BLACK	80009	352-0166-00
	352-0166-01		3	CONN BODY, PL, EL:8 WIRE BROWN	80009	352-0166-01
	352-0166-02		a	CONN BODY, PL, EL:8 WIRE RED	80009	352-0166-02
	352-0166-03		4	CONN BODY, PL, EL:8 WIRE ORANGE	80009	352-0166-03
-239	352-0167-00		2	CONN BODY, PL, EL:9 WIRE BLACK	80009	352-0167-00
	352-0167-04		2	HOLDER, TERM, CON:9 WIRE, YELLOW	80009	352-0167-04
	352-0167-05		2	CONN BODY, PL, EL:9 WIRE GREEN	80009	352-0167-05
-240	352-0168-00		2	CONN BODY, PL, EL:10 WIRE BLACK	80009	352-0168-00
	352-0168-02		2	CONN BODY, PL, EL:10 WIRE RED	80009	352-0168-02
	352-0168-07		2	CONN BODY, PL, EL:10 WIRE VIOLET	80009	352-0168-07
	352-0168-08		1	HOLDER, TERM, CON:10 WIRE, GRAY	80009	352-0168-08
	352-0169-00	B010100 B059999	2	CONN BODY, PL, EL:2 WIRE BLACK	80009	352-0169-00
	352-0169-00	B060000	1	CONN BODY, PL, EL:2 WIRE BLACK	80009	352-0169-00
	352-0169-01		2	CONN BODY, PL, EL:2 WIRE BROWN	80009	352-0169-01
	352-0169-02		2	CONN BODY, PL, EL:2 WIRE RED	80009	352-0169-02
	352-0169-04		1	CONN BODY, PL, EL:2 WIRE YELLOW	80009	352-0169-04
	352-0169-08		4	HOLDER, TERM, CON:2 WIRE, GRAY	80009	352-0169-08
	352-0169-09		1	CONN BODY, PL, EL:2 WIRE WHITE	80009	352-0169-09
-241	352-0171-0-		3	CONN BODY, PL, EL: WIRE BLACK	80009	352-0171-00
	352-0205-00		1	CONN BODY, PL, EL:9 WIRE BLACK	80009	352-0205-00
-242	200-1075-00		4	COVER, ELEC CONN:PLASTIC	00779	1-480435-0

REV. E JULY 1976

Mechanical Parts List--7623A/R7623A Service

Fig. & Index No.	Tektronix Part No.	Serial/Model No Eff Dscont	Qty	1 2 3 4 5 Name & Description	Mfr Code	Mfr Part Number
3-1	390-0229-00		1	CABINET TOP:OSCILLOSCOPE (ATTACHING PARTS)	80009	390-0229-00
-2	211-0007-00		6	SCREW, MACHINE:4-40 X 0.188 INCH, PNH STL	83385	OBD
	211-0101-00		2	SCREW, MACHINE:4-40 X 0.25" 100 DEG, FLH STL	83385	OBD
				---*---		
-3	426-0514-00		1	FRAME, ASK:PLASTIC	80009	426-0514-00
-4	378-0625-02		1	FILTER, LT, CRT:	80009	378-0625-02
-5	331-0258-03		1	MASK, CRT SCALE:	80009	331-0258-03
-6	200-0939-01		1	BEZEL, CRT (ATTACHING PARTS)	80009	200-0939-01
-7	212-0023-00		4	SCREW, MACHINE:8-32 X 0.375 INCH, PNH STL	83385	OBD
	131-1022-00	XB40000	2	CONTACT, ELEC:CRT MASK	80009	131-1022-00
				---*---		
-8	337-1159-00		1	WINDOW, OBS:4.78 X 3.93 X 0.07"PLSTC	80009	337-1159-00
-9	331-0245-00		1	MASK, CR SCALE.	80009	331-0245-00
-10	333-1691-00		1	PANEL, FRONT LEFT	80009	333-1691-00
-11	386-1884-03		1	SPRT, ELCTRN TUB- (ATTACHING PARTS)	80009	386-1884-03
-12	212-0040-00		2	SCREW, MAC HINE:8-32 X 0.375 100 DGK, FLH STL	83385	OBD
	211-0510-00		2	SCREW, MACHINE:6-32 X 0.375 INCH, PNH STL	83385	OBD
				---*---		
			-	SUPPORT INCLUDES:		
-13	386-1517-00		4	SUPPORT, CRT	80009	386-1517-00
-14	204-0380-00		1	BODY, TERMINAL	80009	204-0380-00
-15	131-0765-00		3	CONTACT, ELEC:	80009	131-0765-00
-16	348-0031-00		1	GRMETPLASTIC:156 INCH DIA	80009	348-0031-00
-17			1	CKT BOAR D ASSY.GRATICULE LIGHT(SEE A16 EPL)		
			-	CKT BOARD ASSY INCLUDES:		
-18	378-0614-00		1	REFLECTOR, LIGHT:	80009	378-0614-00
-19	344-0179-00		2	CLIP, REFL RTNG:PLASTIC	80009	344-0179-00
-20	211-0062-00		2	.SCRW, MACHINE:2-56 X 0.312 INCH, RDH STL	83385	OBD
-21	366-1519-00		1	KNOB:PULL	80009	366-1519-00
			-	KNOB INCLUDES:		
	213-0239-00		2	.SETSCREW:3-48 X 0.062 INCH, HEX SOC STL	71159	OBD
-22	366-1077-00		3	KNOB:GRAY	80009	366-1077-00
			-	EACH KNOB INCLUDES:		
	213-0153-00		1	.SETSCRW:5-40 X 0.125 INCH, HEX SOC STL	74445	OBD
-23	366-1391-00		1	KNB :GRAY	80009	366-1391-00
-24	366-1215-00		1	KNOB :GRAY	80009	366-1215-00
			-	.KNOB INCLUDES.		
	213-0153-00		1	.STSCREW:5-40 X 0.125 INCH, HEX SOC STL	74445	OBD
-25	366-1519-01		1	KNOB:MAN	80009	366-1519-01
			-	KNOB INCLUDES:		
	213-0239-00		2	.SETSCREW:3-48 X 0.062 INCH, HEX SOC STL	71159	OBD
-26	366-1391-00		1	KNOB GRAY	80009	366-1391-00
			-	KNOB INCLUDES:		
	213-0140-00		1	SETSCREW:2-56 X 0.94 INCH, HEX SOC STL	70276	OBD
-27	366-1480-02		1	PUSH BUTTON:ON-OFF	80009	366-1480-02
-28	366-1402-12		1	PUSH BUTTON-FAST	80009	366-1402-12
-29	366-1402-25		1	PUSH BUTTON:VAR PERSISTANCE	80009	366-1402-25
-30	366-1402-13		1	PUSH BUTTON:BI STABLE	80009	366-1402-13
-31	426-0681-00		15	FR, PUSH BUTTON:GRAY PLASTIC	80009	426-0681-00
-32	358-0378-00	B010100 B129999	3	BUSHING, SLEEVE PRESS MOUNT	80009	358-0378-00
	358-0378-00	B130000	2	BUSHING, SLEEVE:PRESS MOUNT	80009	358-0378-00
-33			3	RES., VAR (SEE R1430, R1095, R1488A, B EPL) (ATTACHING PARTS FOR EACH)		
-34	210-0583-00		1	NUT, PLAIN, HEX.:0.25-32 X 0.312INCH, BRS	73743	2X20319-402
-35	210-0940-00		1	WASHER, FLAT 0.25 ID X 0.375 INCH OD, STL	79807	OBD
				---*---		
-36			1	RES., VAR: (SEE R1472A, B EPL) (ATTACHING PARTS)		
-37	210-0583-00		1	NUT, PLAIN, HEX.:0.25-32 X 0.312 INCH, BRS	73743	2X20319-402
	210-0940-00		1	WASHER, FLAT0.25ZS ID X 0.375 INCH OD, STL	79807	OBD
-38	210-0223-00		1	TERMINAL, LUG:0.25 INCH DIA, SE	78189	2101-14-03-252ON
				---*---		

Mechanical Parts List--7623A/R7623A Service

Fig. & Index No.	Tektronix Part No.	Serial/Model No Eff Dscnt	Qty	1 2 3 4 5 Name & Description	Mfr Code	Mfr Part Number
3-39	333-1843-00	B010100 B129999	1	PANEL, FRONT	80009	333-1843-00
-40	333-1843-01	B130000	1	PANEL, FRONT:	80009	333-1843-01
-41	211-0101-00		1	CKT BOARD ASSY:MODE SWITCH(SEE A17 EPL) (ATTACHING PARTS)		
			2	SCREW, MACHINE:4-40 X 0.25" 100 DEG, FLH STL	83385	OBD
-42	131-0608-00		-	.CKT BOARD ASSY INCLUDES:		
-43	260-1593-00		9	.CONTACT, ELEC:0.365 INCH LONG22526	47357	
-44	361-0411-00		1	.SWITCH PUSH:FAST/VAR PERSIST/BI STABLE		OBD
-45	211-0062-00		5	.SPACER, PUSH SW:0.13 W X 0.375 INCH L, PLSTC	71590	J64285-00
-46	220-0637-00		2	.SCREW, MACHINE:2-56 X 0.312 INCH, RDH STL	83385	OBD
-47	136-0387-01		1	.NUT BLOCK:4-40/2-56 INCH THREADS	80009	220-0637-00
-48	136-0387-00		1	JACK, TIP:BLACK	71279	4352-1-0310
-49	132-0027-00		3	JACK, TIP:GRAY	71279	4352-1-0318
-50	212-0040-00		2	ADAPTER, CA TO C: (ATTACHING PARTS FOR EACH)	24655	0874-6540
-51	386-2119-00		1	SCREW, MACHINE:8-32 X 0.375 100 DEG, FLH STL	83385	OBD
-52	211-0538-00		1	PANEL, REAR:POWER SUPPLY (ATTACHING PARTS)	80009	386-2119-00
-53	211-0589-00		4	SCREW, MACHINE:6-32 X 0.312"100 DEG, FLH STL	83385	OBD
			2	SCREW, MACHINE:6-32 X 0.312 INCH, PNH BRS	83385	OBD
-54	351-0313-00		1	GUIDE, RACKMOUNT:19.218 INCH LONG, PAIR (ATTACHING PARTS)	80009	351-0313-00
-55	210-0458-00		12	NUT, PLAIN, EXT W:8-32 X 0.344 INCH, STL	83385	OBD
-56	367-0138-00		2	HANDLE, BOW: (ATTACHING PARTS FOR EACH)	06515	14053-A-1032-18
-57	212-0518-00		2	SCREW, MACHINE-10-32 X 0.312 INCH, PNH STL	83385	OBD
-58	200-1448-00		1	COVER, ACCESS: (ATTACHING PARTS)	80009	200-1448-00
-59	211-0008-00		6	SCREW, MACHINE:4-40 X 0.25 INCH, PNH STL	83385	OBD
-60	200-1401-00		1	COVER, ACCESS: (ATTACHING PARTS)	80009	200-1401-00
-61	211-0101-00		5	SCREW, MACHINE:4-40 X 0.25" 100 DEG, FLC STL	83385	OBD
-62	210-0201-00		1	TERMINAL, LUG:SE #4 (ATTACHING PARTS)	78189	2104-04-00-2520N
-63	210-0586-00		1	NUT, PLAIN, EXT W:4-40 X 0.25 INCH, STL	78189	OBD
	644-0056-00		1	POWER SW ASSY (ATTACHING PARTS)	80009	644-0056-00
-64	210-0586-00		2	NUT, PLAIN, EXT W:4-40 X 0.25 INCH, STL	78189	OBD
-65	407-1570-00		-	.POWER SWITCH ASSY INCLUDES.		
-66	211-0008-00		1	.BRACKET, ANGLE:POWER SWITCH	80009	407-1570-00
-67	200-1731-00		2	.SCREW, MACHINE:4-40 X 0.25 INCH, PNH STL	83385	OBD
-68	211-0034-00		1	.COVER, ELEC SW:	80009	200-1731-00
-69	210-0850-00		1	.SCREW, MACHINE:2-56 X 0.500 INCH, PNH, STL	77250	OBD
-70	210-0405-00		1	.WASHER, FLAT:0.093ID X 0.281 INCH OD, STL	12327	OBD
-71	260-1709-00		1	.NUT, PLAIN, EX.:2-56 X 0.188 INCH, BRS	73743	2X12157-402
-72	343-0004-00		1	.SWITCHPUSH:POWER	77342	A9T5 762-6-3
-73	211-0538-00		1	CLAMP, LOOP:0.312 INCH DIAMETER, PLSTC (ATTACHING PARTS)	95987	5-16-6B
-74	210-0863-00		1	SCREW, MACHINE:6-32 X 0.312"100 DEG, FLH STL	83385	OBD
-75	210-0457-00		1	WSHR, LOOP CLAMP:FOR 0.50" WIDE CLAMP, STL	95987	C191
			1	NUT, PLAIN, EXT W:6-32 X 0.312 INCH, STL	83385	OBD
-76	343-0004-00		1	CLAMP, LOOP:0.312 INCH DIAMETER, PLSTC (ATTACHING PARTS)	95987	5-16-6B
-77	211-0510-00		1	SCREW, MACHINE:6-32 X 0.375 INCH, PNH STL	83385	OBD
-78	210-0202-00		1	TERMINAL, LUG:SE #6	78189	2104-06-00-2520N
-79	210-0863-00		1	WSHR, LOOP CLAMP:FOR 0.50" WIDE CLAMP, STL	95987	C191
	210-0457-00		1	NUT, PLAIN, EXT W:6-32 X 0.312 INCH, STL	83385	OBD

Mechanical Parts List--7623A/R7623A Service

Fig. & Index No.	Tektronix Part No.	Serial/Model No Eff Dscnt	Qty	1 2 3 4 5 Name & Description	Mfr Code	Mfr Part Number
3-80	343-0004-00		1	CLAMP, LOOP:0.312 INCH DIAMETER, PLSTC (ATTACHING PARTS)	95987	5-16-68
-81	210-0457-00		1	NUT, PIN, EX W6-32 X 0.312 INCH, STL	83385	OBD
-82	210-0863-00		1	WSHR, LOOP CLAMP:FOR 0.50"WIDE CLAMP, STL ---*---	95987	C191
-83	386-2412-00		1	SUPPORT, CRT:80009 386-2412-00 (ATTACHING PARTS)		
-84	211-0538-00		2	SCREW, MACHINE:6-32 X 0.312"100 DEG, FLH STL	83385	OBD
-85	211-0507-00		1	SCREW, MACsINE:6-32 X 0.312 INCH, PNH STL	83385	OBD
-85	210-0458-00		3	NUT, PLAIN, EXT W:8-32 X 0.344 INCH, STL ---*---	83385	OBD
-86	337-1731-00		1	SHIELD, ELEC:REGULATOR (ATTACHING PARTS)	80009	337-1731-00
-87	211-0504-00		4	SCREW, MACHINE:6-32 X 0.25 INCH, PNH STL ---*---	83385	OBD
-88	441-1060-01		1	CHAS, ELEC EQPT:MAIN (ATTACHING PARTS)	80009	441-1060-01
-89	211-0538-00		1	SCREW, MACHINE:6-32 X 0.312"100 DEG, FLH TL	83385	OBD
-90	211-0504-00		2	SCREW, MACHINE:6-32 X 0.25 INCH, PNH STL	83385	OBD
-91	211-0025-00		2	SCREW, MACHINE:4-40 X 0.375 100 DEG, FLHSTL ---*---	83385	OBD
-92	-----		6	TRANSISTOR:(SEE Q874, 903, O850, :933, Q958, Q988 EPL) - (ATTACHING PARTS FOR EACH)		
-93	211-0511-00		2	SCREW, MACHINE:6-32 X 0.50 INCH, PNH STL	83385	OBD
-94	386-0978-00		1	INSULATOR, PLATE:0.002 INCH MICA, FOR O-3 ---*---	80009	386-0978-00
-95	-----		1	CKT BOARD ASSY:REGULATOR(SEE A12 EPL) - .CKT BOARD ASSY INCLUDES:		
-96	131-0608-00		49	.CONTACT, ELEC:0.365 INCH LONG	22526	47357
-97	136-0361-00		6	.SOCKET, PLUG-IN:	80009	136-0361-00
-98	131-0847-00		12	.TERMINAL STUD:6-32 X 0.435 INCH LONG	80009	131-0847-00
-99	136-0384-00		12	.CONTACT, ELEC:FOR 0.04 DIAMETER PIN	00779	52120
-100	136-0183-00		3	.SOCKET, PLUG-IN:3 PIN	80009	1 36-0183-00
-101	136-0235-00		6	.SOCKET, PLUG-IN:6 CONTACT, ROUND	71785	133-96-12-062
-102	136-0252-04	B010100 B010149	36	.CONTACT, ELEC:0.188 INCH LONG	22526	75060
-102	136-0252-04	B010150	9	.CONTACT, ELEC' 0.188 INCH LONG	22526	75060
-102	136-0350-00	B010150	9	.SOCKET, PLUG-IN:3 PIN, LOW PROFILE	80009	136-0350-00
-103	136-0269-02		1	.SOCKET, PLUG-IN:14 CONTACT, LOW CLEARANCE	01295	C931402
-104	214-0579-00		1	.TERM., TEST PT:0.40 INCH LONG	80009	214-0579-00
-105	214-1291-00		3	.HEAT SINK, ELEC:XSTR, 0.72 OD X 0.375"H	05820	207-AB
-106	344-0154-00		2	.CLIP, ELECTRICAL:FOR 0.25 INCH DIA FUSE	80009	344-0154-00
-107	220-0614-00		1	NUT BLOCK:6-32 X 0.347 X 1.25 INCH LONG (ATTACHING PARTS) ---*---	80009	220-0614-00
-108	211-0507-00		2	SCREW, MACHINE:6-32 X 0.312 INCH, PNH STL ---*---	83385	OBD
-109	386-2054-00		1	SUPPORT:POWER SUPPLY (ATTACHING PARTS)	80009	386-2054-00
-110	211-0101-00		2	SCREW, MACHINE:4-40 X 0.25" 100 DEG, FLU STL ---*---	83385	OBD
-111	351-0295-02		3	GUIDE, SLIDE: (ATTACHING PARTS FOR EACH)	80009	351-0295-02
-112	211-0105-00		1	SCREW, MACHINE:4-400 X 0.188"100 DEG, FL STL	83385	OBD
-113	211-0101-00	B010100 B080984	3	SCREW, MACHINE:4-40 X 0.25" 100 DEG, FLH STL	83385	OBD
-113	211-0054-00	B080985	3	SCREW, MACHINE:6-32 X 0.312 INCH, PNH STL ---*---	83385	OBD
-114	351-0305-01		3	GUIDE, PLUG-IN:UPPER (ATTACHING PARTS FOR EACH)	80009	351-0305-01
-115	211-0105-00		1	SCREW, MACHINE:4-40 X 0.188#100 DEIG, FLH STL ---*---	83385	OBD
-116	129-0441-00		2	POST, ELEC-MECH:0.125 OD X 5.045 INCH LONG (ATTACHING PARTS FOR EACH)	80009	129-0441-00
-117	211-0087-00		2	SCREW, MACHINE:2-56 X 0.188 INCH, FLH SST ---*---	70318	OBD
-118	407-1145-02		1	BRKT, HEAT SINK:RIGHT (ATTACHING PARTS)	80009	407-1145-02
-119	211-0504-00		1	SCREW, MACHINE:6-32 X 0.25 INCH, PNH STL	83385	OBD
-120	437-0143-01		1	FRAME ASSEMBLY:	80009	437-0143-01
-121	348-0354-00		2	SHLD GSKT, ELEC:8.10 INCH LONG	80009	348-0354-00
-122	384-1060-00		1	EXTENSION.SHAFT:7.831 INCH LONG	80009	384-1060-00

Mechanical Parts List - 7623A/R7623A Service

Fig.& Index No.	Tektronix Part No.	Serial/Model No Eff Dscnt	Qty	1 2 3 4 5 Name & Description	Mfr Code	Mfr Part Number
4-1	-----		1	CKT BOARD ASSY: VERTICAL AMP(SEE A5 EPL) (ATTACHING PARTS)		
-2	211-0008-00		3	SCREW, MACHINE: 4-40 X 0.25 INCH, PNH STL ---*---	83385	OBD
-3	-----		-	CKT BOARD ASSY INCLUDES:		
-4	131-0566-00		4	.LINK, TERM.CONNE: 0.086 DIA X 2.375 INCH L	0000C	L-2007-1
-4	131-0608-00		8	.CONTACT, ELEC: 0.365 INCH LONG	22526	47357
-5	131-1003-00		3	.CONNECTOR BODY, : CKT BD MT, 3 PRONG	80009	131-1003-00
-6	136-0252-04	B010100 B010149	36	.CONTACT, ELEC: 0.188 INCH LONG	22526	75060
-6	136-0350-00	B010150	9	.SOCKET, PLUG-IN: 3 PIN, LOW PR OFI LE	80009	136-0350-00
-7	214-0579-00		2	.TERM., TEST PT: 0.40 INCH LONG	80009	214-0579-00
-8	131-0775-00		2	.TERMINAL, STD : 6-32 X 0.25 X 0.375" LG (ATTACHING PARTS FOR EACH)	80009	131-0775-00
-9	211-0503-00		1	.SCREW, MACHINE: 6-32 X 0.188 INCH, PNH STL ---*---	83385	OBD
-10	346-0117-00		1	.STRAP, GROUNDING:	80009	346-0117-00
-11	-----			CKT BOARD ASSY-HORIZONTAL AMP(SEE A6 EPL) (ATTACHING PARTS)		
-12	211-0008-00		2	SCREW, MACHINE: 4-40 X 0.25 INCH, PNH STL	83385	OBD
-13	-----		-	CKT BOARD ASSY INCLUDES:		
-13	131-0608-00		23	.CONTACT, ELEC: 0.365 INCH LONG	22526	47357
-14	131-1003-00		2	.CONNECTOR BODY, : CKT BD MT, 3 PRONG	80009	131-1003-00
-15	136-0252-04		26	.CONTACT, ELEC: 0.188 INCH LONG	22526	75060
-16	136-0260-01		1	.SOCKET, PLUG-IN: 16 CONTACT, RECT SHAPE	71785	133-51-02-075
-17	214-0579-00		1	.TERM., TEST PT: 0.40 INCH LONG	80009	214-0579-00
-18	210-0627-00		2	RIVET, SOLID: 0.042 DIA X 0.25 INCH, RDH	80009	210-0627-00
-19	343-0097-00		2	RTNR, TRANSISTOR: HEAT SINK (ATTACHING PARTS FOR EACH)	80009	343-0097-00
-20	210-0599-00		2	NUT, SLEEVE: 4-40 X 0.391 INCH LONG	80009	210-0599-00
-21	214-0368-00		1	SPRING, HLCPS: 0.24 DIA X 0.438 INCH LONG ---*---	80009	214-0368-00
-22	352-0062-00		2	HOLDER, HEAT SK: 1.187 X 1.187 INCHES, PLSTC (ATTACHING PARTS FOR EACH)	80009	352-0062-00
-23	211-0008-00		2	SCREW, MACHINE: 4-40 X 0.25 INCH, PNH STL	83385	OBD
-24	211-0012-00		2	SCREW, MACHINE: 4-40 X 0.375", PNH STL	83385	OBD
-25	210-0406-00		4	NUT, PLAIN, HEX.: 4-40 X 0.188 INCH, BRS ---*---	73743	2X12161-402
-26	119-0368-00		1	DELAY LINE, ELEC: (ATTACHING PARTS)	80009	119-0368-00
-27	213-0034-00		2	SCR, TPG, THD CTG: 4-40 X 0.188 INCH, PNH STL ---*---	83385	OBD
-28	351-0087-00		a	GUIDE, CKT CARD: 4.75 INCH LONG, PLASTIC	80009	351-0087-00
-29	348-0031-00		1	GROMMET, PLASTIC: 0.156 INCH DIA	80009	348-0031-00
-30	348-0064-00		a	GROMMET, PLASTIC: 0.625 INCH DIA	80009	348-0064-00
-31	255-0334-00		FT	PLASTIC CHANNEL: 12.75 INCHES LONG	80009	255-0334-00
-32	407-1001-00		1	BRKT, CRT SHLD: FRONT (ATTACHING PARTS)	80009	407-1001-00
-33	211-0589-00		2	SCREW, MACHINE: 6-32 X 0.312 INCH, PNH BRS	83385	OBD
-34	210-0457-00		2	NUT, PLAIN, EXT W: 6-32 X 0.312 INCH, STL	83385	OBD
-34	211-0538-00		2	SCREW, MACHINE: 6-32 X 0.312"100 DEG, FLH STL ---*---	83385	OBD
-35	-----		1	CKT BOARD ASSY: STORAGE(SEE A14 EPL) (ATTACHING PARTS)		
-36	211-0008-00		2	SCREW, MACHINE: 4-40 X 0.25 INCH, PNH STL	83385	OBD
-37	129-0236-00		2	POST, METALLIC: 4-40 X 0.188 X 0.375" LONG	06540	9726-A-D440
-38	210-0586-00		2	NUT, PLAIN, EXT W: 4-40 X 0.25 INCH, STL ---*---	78189	OBD
-39	-----		-	CKT BOARD ASSY INCLUDES:		
-39	131-0608-00	B010100 B129999	98	.CONTACT, ELEC: 0.365 INCH LONG	22526	47357
-39	131-0608-00	B130000	111	.CONTACT, ELEC: 0.365 INCH LONG	22526	47357
-40	136-0252-04	B010100 B010149	201	.CONTACT, ELEC: 0.188 INCH LONG	22526	75060
-40	136-0252-04	B010150	12	.CONTACT, ELEC: 0.188 INCH LONG	22526	75060
-40	136-0350-00	B010150 B129999X	63	.SOCKET, PLUG-IN: 3 PIN, LW PROFILE	80009	136-0350-00
-41	136-0260-02		3	.SOCKET, PLUG-IN: 16 CONTACT, LOW CLEARANCE	01295	C931602

Mechanical Parts List - 7623A/R7623A Service

Fig.& Index No.	Tektronix Part No.	Serial/Model No Eff Dscont	Qty	1 2 3 4 5 Name & Description	Mfr Code	Mfr Part Number
4-42	136-0269-02		4	.SOCKET, PLUG-IN: 14 CONTACT, LOW CLEARANCE	01295	C931402
	131-0993-00	XB060000 B129999 B130000	1	.LINK, TERM.CONNE: JUMPER	00779	530153-2
	131-0993-00		2	.LINK, TERM, CONNE: JUMPER	00779	530153-2
-43	214-0579-00		8	.TERM., TEST PT: 0.40 INCH LONG	80009	214-0579-00
-44	260-1378-00		1	.SWITCH, PUSH: VERT MOD E	71590	2KBC140000-608
-45	366-1402-02		1	.PUSH BUTTON: LEFT	80009	366-1402-02
-46	366-1402-03		1	.PUSH BUTTON: ALT	80009	366-1402-03
-47	366-1402-04		1	.PUSH BUTTON: ADD	80009	366-1402-04
-48	366-1257-31		1	.PUSH BUTTON: CHOP	80009	366-1257-31
-49	366-1402-06		1	.PUSH BUTTON: RIGHT	80009	366-1402-06
-50	260-1379-00		1	.SWITCH, PUSH: TRIG SOURCE	71590	KBC120000-595
-51	366-1402-02		1	.PUSH BUTTON: LEFT	80009	366-1402-02
-52	366-1402-07		1	.PUSH BUTTON: VERT MODE	80009	366-1402-07
-53	366-1402-06		1	.PUSH BUTTON: RIGHT	80009	366-1402-06
-54	260-1594-00		1	.SWITCH PUSH: NON STORE/STORE/SAVE	OBD	
-55	366-1402-08		1	.PUSH BUTTON: NONSTORE	80009	366-1402-08
-56	366-1257-85		1	.PUSH BUTTON: GRAY--STORE	80009	366-1257-85
-57	366-1402-21		1	.PUSH BUTTON: SAVE	80009	366-1402-21
-58	361-0411-00		15	.SPACER, PUSH SW: 0.13 W X 0.375 INCH L, PLSTC	71590	J64285-00
-59	384-1099-00		5	.EXTENSION SHAFT: PUSH BUTTON, 1.54 INCH LONG	80009	384-1099-
00						
-60	384-1136-00		6	.EXTENSION SHAFT: 0.95 INCH LONG	80009	384-1136-00
-61	352-0019-00		2	.HOLDER: PLASTIC (ATTACHING PARTS FOR EACH)	80009	352-0019-00
-62	213-0088-00		1	/SCR, TPG, THD CTG: 4-24 X 0.25 INCH, PNH STL ---*---	83385	OBD
	200-1799-00	XB080985	1	COVER, PROT: (ATTACHING PARTS)	80009	200-1799-00
	211-0008-00	XB080985	1	SCREW, MACHINE: 4-40 X 0.25 INCH, PNH STL	83385	OBD
	210-0801-00	XB800985	1	WASHER, FLAT: 0.14 ID X 0.281 OD NP STL ---*---	12327	OBD
-63	407-1397-00		1	BRACKET, ANGLE: (ATTACHING PARTS)	80009	407-1397-00
-64	211-0147-00		2	SCREW, MACHINE: 4-40 X 0.25 INCH, PNH STL	83385	OBD
-65	210-0586-00		2	NUT, PLAIN, EXT W: 4-40 X 0.25 INCH, STL ---*---	78189	OBD
-66	386-2411-00		1	SUPPORT, CRT: (ATTACHING PARTS)	80009	386-2411-00
-67	211-0559-00		2	SCREW, MACHINE: 6-32 X 0.375"100 DEG, FLH STL	83385	OBD
-68	210-0457-00		2	NUT, PLAIN, EXT Wu6-32 X 0.312 INCH, STL	83385	OBD
-69	211-0510-00		2	SCREW, MACHINE: 6-32 X 0.375 INCH, PNH STL	83385	OBD
-70	210-0993-00		2	WSHR, SHOULDERED: 0.143" ID X 0.75" OD, BRS ---*---	79807	OBD
-71	407-1186-00		1	BRKT, CRT MTG: (ATTACHING PARTS)	80009	407-1186-00
	211-0510-00		2	SCREW, MACHINE: 6-32 X 0.375 INCH, PN ST	83385	OBD
	210-0457-00		2	NUT, PLAIN, EXT W: 6-32 X 0.312 INCH, STL ---*---	83385	OBD
-72	672-0572-00	B1120000	1	CKT BOARD ASSY: PROTECTION AND READOUT	80009	672-0572-00
	-----	XB120000	1	.CKT BOARD ASSY: PROTECTION (SEE A18 EPL)		
-73	131-0589-00	XB12000	20	...CONTACT, ELEC: 0.46 INCH LONG	22526	47350
-74	253-0162-00	XB12000	FT	..TAPE, PRESS SENS: 0.062 X 0.125 X 0.208' L	04963	OBD
-75	210-0702-00	XB120000	2	.EYELET, METALLIC: 0.047 OD X 0.125 INCH LONG	07707	56127
-76	-----		1	.CKT BOARD ASSY: READOUT (SEE A13 EPL) (ATTACHING PARTS)		
-77	211-0008-00		1	.SCREW, MACHINE: 4-40 X 0.25 INCH, PNH STL ---*---	83385	OBD
	-----		-	CKT BOARD ASSY INCLUDES:		
-78	131-0608-00		40	CONTACT, ELEC: 0.365 INCH LONG	22526	47357
-79	131-1003-00		6	CONNECTOR BODY, : CKT D MT, 3 PRONG	80009	131-1003-00
-80	136-0235-00		1	SOCKET, PLUG-IN: 6 CONTACT, ROUND	71785	133-96-12-062
-81	136-0252-1		6	.CONTACT, ELEC: 0.178 INCH LONG	00779	1-332095-2
	136-0252-04		39	CONTACT, ELEC: 0.188 INCH LONG	22526	75060
-82	136-0260-02		3	SOCKET, PUG-IN: 16 CONTACT, LOW CLEARANCE	01295	C931602
-83	136-0269-02		3	.SOCKET, PLUG-IN: 14 CONTACT, LOW CLEARANCE	01295	C931402
-84	260-0723-00		1	SWITCH, SLIDE: DPDT, 0.5A, 125VAC	79727	GF126-0028

Mechanical Parts List - 7623A/R7623A Service

Fig.& Index No.	Tektronix Part No.	Serial/Model No Eff Dscont	Qty	1 2 3 4 5 Name & Description	Mfr Code	Mfr Part Number
4-85	214-0579-00	B00100 B121999	19	. TERM., TEST PT: 0.40 INCH LONG	80009	214-0579-00
	214-0579-00	B120000	20	. TERM., TEST PT: 0.40 INCH LONG	80009	214-0579-00
-86	195-0114-09		1	LEAD SET: READOUT	80009	195-0114-09
	621-0474-01		1	POWER SUPPLY: HIGH VOLTAGE (ATTACHING PARTS)	80009	621-0474-01
-87	211-0504-00		4	SCREW, MACHINE: 6-32 X 0.25 INCH, PNH STL ---*---	83385	OBD
	-----		-	.HIGH VOLTAGE ASSY INCLUDES:		
-88	351-0324-00		2	.GUIDE, CKT CARD:	80009	351-0324-00
-89	-----		1	.CKT BOARD ASSY: Z AXIS(SEE A8 EPL) (ATTACHING PARTS)		
-90	211-0008-00		3	.SCREW, MACHINE: 4-40 X 0.25 INCH, PNH STL ---*---	83385	OBD
	-----		-	.CKT BOARD ASSY INCLUDES:		
-91	131-0608-00		52	.CONTACT, ELEC: 0.365 INCH LNG	22526	47357
-92	131-1003-00		3	.CONNECTOR BODY, : CKT B MT, 3 PRONG	80009	131-1003-00
-93	136-0252-04		45	.CONTACT, E EC: 0.188 INCH LONG	22526	75060
	131-0566-00	XBO020000	1	.LINK, TERM.CONNE0.086 DIA X 2.375 INCH L	0000C	L-2007-1
-94	-----		1	.CKT BOARD ASSY: ANODE(SEE A9 EPL) (ATTACHING PARTS)		
-95	211-0040-00		3	.SCREW, MACHINE: 4-40 X 0.25", BDCH PLSTC	26365	OBD
-96	211-0008-00		1	.SCREW, MACHINE: 4-40 X 0.25 INCH, PNH STL ---*---	83385	OBD
-97	-----		1	.CKT BOARD ASSY: HIGH VOLTAGE(SEE A10 EPL) (ATTACHING PARTS)		
-98	211-0008-00		3	.SCREW, MACHINE.4-40 X 0.25 INCH, PNH STL	83385	OBD
-99	211-0040-00		1	.SCREW, MACHINE: 4-40 X 0.25", BDCH PLSTC ---*---	26365	OBD
	-----		-	.CKT BOARD ASSY INCLUDES:		
-100	124-0118-00		1	.TERMINAL BOARD: NOTCH (ATTACHING PARTS)	80009	124-0118-00
-101	361-0007-00		1	.SPACER, SLEEVE0.250 INCH DIA, PLASTIC ---*---	80009	361-0007-00
	-----		-	...TERMINAL STRIP INCLUDES:		
-102	355-0046-00		1	...MOUNT, TERM.BD0.577 INCH H	80009	355-0046-00
-103	124-0119-00		1	.TERMINAL BOARD: 2 NOTCH (ATTACHING PARTS)	80009	124-0119-00
-104	361-0007-00		1	.SPACER, S E: 0.250 INCH DIA, PLASTIC ---*---	80009	361-0007-00
	-----		-	...TERMINAL STRIP INCLUDES:		
-105	355-0046-00		1	...MOUNT, TERM. BD: 0.577 INCH H	80009	355-0046-00
-106	131-0589-00		7	.CONTACT, ELEC: 0.46 INCH LONG	22526	47350
	131-0608-00		21	.CONTACT, ELEC: 0.365 INCH LONG	22526	47357
-107	136-0252-04		9	.CONTACT, ELEC0.188 INCH LONG	22526	75060
-108	166-0292-00		2	.SPACER, SLEEVE: PLSTC, 0.155 DIA X 0.065"L	80009	166-0292-00
-109	214-0579-00		1	.TERM., TEST PT: 0.40 INCH LONG	80009	214-0579-00
-110	-----		1	.TRANSISTOR: (ATTACHING PARTS)		
-111	213-0146-00		2	.SCR, TPG, THD OR: 6-20 X 0.313 INCH, PNH STL	83385	OBD
-112	386-0978-00		1	.INSULATOR, PLATE: 0.002 INCH MICA, FOR TO-3 ---*---	80009	386-0978-00
-113	136-0280-00		1	.SOCKET, PLUG-IN: FOR TO-3 (ATTACHING PARTS)	22753	PTS1
-114	211-0101-00		2	.SCREW, MACHINE: 4-40 X 0.25" 100 DEG, FLH STL	83385	OBD
-115	210-0586-00		2	.NUT, PLAIN, EXT W: 4-40 X 0.25 INCH, STL ---*---	78189	OBD
-116	348-0063-00		1	.GROMMET , PLASTIC: 0.50 INCH DIA	80009	348-0063-00
-117	343-0088-00		1	.CLAMP, LOOP: 0.062 INCH DIA	80009	343-0088-00
-118	348-0085-00	B0100 B099999	FT	.PLASTIC CHANNEL: 12.75 INCHES LONG	80009	348-0085-00
	358-0166-00	B100000	1	.GROMMET, PLASTIC: BLACK	80009	358-0166-00
-119	29-0251-01		1	.POST, NONMETALLI: 4-40 X 0.25 OD X 1.125" L (ATTACHING PARTS)	80009	129-0251-01
-120	129-0236-00		1	.POST, METALLIC: 4-40 X 0.188 X 0.375 INCH LONG	06540	9726-A-D440
	211-0008-00		1	.SCREW, MACHINE: 4-40 X 0.25 INCH, PNH STL	83385	OBD
	210-004-00	XB091130	2	.WASHER, LOCK: INTL, .12 ID X 0.26"OD, STL ---*---	78189	1204-00-00-0541C

Mechanical Parts List - 7623A/R7623A Service

Fig. & Index No.	Tektronix Part No.	Serial/Model No Eff Dscont	Qty	1 2 3 4 5 Name & Description	Mfr Code	Mfr Part Number
4-121	129-0251-00		3	.POST, NONMETALLI:4-40 X 0.25 OD X 1.125" L (ATTACHING PARTS)	80009	129-0251-00
-122	211-0040-00		1	.SCREW, MACHINE: 4-40 X 0.25", BDCH PLSTC	26365	OBD
-123	129-0143-00		3	.INSULATOR, STDF: 0.312 OD X 0.406" L, NYLON (ATTACHING PARTS FOR EACH)	80009	129-0143-00
-124	211-0008-00		1	.SCREW, MACHINE: 4-40 X 0.25 INCH, PNH STL ---*---	83385	OBD
-125	131-0773-00		1	.CONN, RCPT, ELEC:	01009	8111
-126	337-1538-01		1	.SHIELD, ELEC: HIGH VOLTAGE	80009	337-1538-01
	343-0002-00		1	.CLAMP, LOOP0.188 INCH DIA	95987	3-16-6B
-127	441-1192-00		1	CHASSIS, SCOPE: MAIN (ATTACHING PARTS)	80009	441-1192-oo00
-128	211-0590-00		2	SCREW, MACHINE: 6-32 X 0.25 INCH, PNH STL	83385	OBD
-129	210-0457-00		2	NUT, PAIN, EXT W: 6-32 X 0.312 INCH, STL ---*---	83385	OBD
	-----		-	.CHASSIS INCLUDES:		
-130	343-0205-01		1	.RING, CLP, CRT RE: (ATTACHING PARTS)	80009	354-0347-00
-131	211-0507-00		4	.SCREW, MACHINE: 6-32 X 0.312 INCH, PNH STL ---*---	83385	OBD
-132	354-0347-00		1	.RTNR, ELECTRON T: (ATTACHING PARTS)	80009	343-0205-01
-133	211-0170-00		2	.SCREW, MACHINE: 4-40 X 2.75 INCH, PNH STL	83385	OBD
-134	214-1333-00		2	.SPRING, HLCPS: 0.213 OD X 0.375 INCH LONG ---*---	80009	214-1333-00
-135	-----		1	COIL: (ATTACHING PARTS)		
-136	213-0138-00		2	SCR, TPG, THD FOR: 4-40 X 0.188 INCH, PNH STL	83385	OBD
-137	343-0217-00		1	CLAMP, COIL: ---*---	80009	343-0217-00
	342-0182-00		1	INSULATOR: CRT SHIELD	80009	342-0182-00
	342-0184-00		1	INSULATOR: CRT FRONT	80009	342-0184-00
-138	337-1531-00		1	SHIELD, CRT:	80009	337-1531-00
-139	378-0041-01		1	FIL ELEM AIR SOILED	80009	378-0041-01
-140	386-2401-02		1	PANEL, REAR: (ATTACHING PARTS)	80009	386-2401-02
-141	211-0565-00		4	SCREW, MACHINE: 6-32 X 0.250 INCH, TRH STL	83385	OBD
-142	211-0538-00		4	SCREW, MACHINES6-32 X 0.312"100 DEG, FLH STL ---*---	83385	OBD
-143	358-0025-00		1	BSHG, STRAIN RLF:	28520	SR6P4
-144	161-0033-09		1	CABLE ASSY, PWRT3 WIRE, 92 INCH LONG	16428	KH8035
-145	131-0955-00		6	CONNECTOR, RCPT, BNC, MALE (ATTACHING PARTS FOR EACH)	24931	28JR00-1
-146	210-0255-00		1	TERMINAL, LUG:0.391" ID INT TOOTH ---*---	80009	210-0255-00
-147	-----			FUSEHOLDER: W/HARDWARE	75915	342012
-148	200-1388-00	B010100 B091389	1	COVER, FUSE:	80009	200-1388-00
	200-1388-01	E091390	1	COVER, FUSE: ---*---		
-149	210-0204-00		1	TERMINAL, LUG: 0.146 INCH DIA DE, 45 DEG BEND (ATTACHING PARTS)	78189	2157-06-01-2520N.
-150	211-0504-00		1	SCREW, MACHINE: 6-32 X 0.25 INCH, PNH STL	83385	OBD
-151	210-0407-00		1	NUT, PLAIN, HEX.: 6-32 X 0.25 INCH, BRS ---*---	73743	3038228-402
-152	346-0077-00		1	STRAP, TIE DOWN,	80009	346-0077-00
-153	-----		1	CKT BOARD ASSY: OUTPUT SIGNALS(SEE A7 EPL) (ATTACHING PARTS)		
-154	211-0008-00		2	SCREW, MACHINE: 4-40 X 0.25 INCH, PNH STL ---*---	83385	OBD
	-----		-	.CKT BOARD ASSY .INCLUDES:		
-155	131-0608-00		10	.CONTACT, ELEC: 0.365 INCH LONG	22526	47357
-156	131-1003-00		2	.CONNECTOR BODY, : CKT D MT, 3 PRONG	80009	131-1003-00

Mechanical Parts List - 7623A/R7623A Service

Fig. & Index No.	Tektronix Part No.	Serial/Model No Eff Dscnt	Qty	1 2 3 4 5 Name & Description	Mfr Code	Mfr Part Number
4-157	136-0252-01		2	.CONTACT, ELEC: 0.178 INCH LONG	00779	1-332095-2
	136-0252-04	010100 B010149	27	.SOCKET, PIN TER: 0.188 INCH LON	22526	75060
	136-0350-00	B010150	9	.SOCKET, PLUG-IN: 3 PIN, LOW PROFILE	80009	136-0350-00
-158	214-0579-00		1	.TERM., TEST PT: 0.40 INC LONG	80009	214-0579-00
-159	260-0984-00		1	.SWITCH, SLIDE: DP 3 POSN, 0.SA, 125VAC-DC	79727	G-128PC/7140
-160	119-0390-00		1	PAN, AXIAL.46 CFM, 1L9, 115 VAC, 60 HZ	28875	MBS-2107F-0-1
	210-0586-00		4	.NUT, PLAIN, EXT W: 4-40 X 0.25 INCH, STL	78189	OBD
				---*---		
-161	386-2410-01		1	.SUBPANEL, REAR: (ATTACHING PARTS)	80009	386-2410-01
	211-0508-00		2	.SCREW, MACHINE: 6-32 X 0.312"100 DEG, FLH STL	83385	OBD
-162	211-0504-00		2	.SCREW, MACHINE: 6-32 X 0.25 INCH, PNH STL	83385	OBD
-163	211-0008-00		1	.SCREW, MACHINE: 4-40 X 0.25 I , PNH STL	83385	OBD
-164	213-0088-00		1	.SCR, TPG, TD CG: 4-24 X 0.25 INCH, PNH STL	83385	OBD
				---*---		
-165	175-1091-00		1	.CABLE, SP, ELEC: (4) #18 STRANDED WIRE	80009	175-1091-00
	614-0077-05		1	.POWER SUPPLY: LOW VOLTAGE (ATTACHING PARTS)	80009	614-0077-05
	212-0040-00		6	.SCREW, MACHINE: 8-32 X 0.375 100 DG, FL STL	83385	OBD
				---*---		
	-----		-	.POWER SUPPLY INCLUDES:		
-166	-----		1	.CKT BOARD ASSY: RECTIFIER(SEE AII EPL) (ATTACHING PARTS)		
-167	211-0511-00		2	.SC E, MACHINE: 6-32 X 0.50 NCH, PNH STL	83385	OBD
-168	210-0863-00		1	.WSHR, LOOP CLAP: FOR 0.50" WIDE CLAMP, STL	95987	C191
-169	343-0004-00		1	.CLAMP, LOOP: 0.312 NCH DIAMETER, PLSTC	95987	5-16-6B
-170	211-0507-00		2	.SCREW, MACHINE 6-32 X 0.312 INCH, PNH STL	83385	OBD
-171	210-0202-00		1	.TERMINAL, LUG: SE #6 ---*---	78189	2104-06-00-2520N
			-	.CKT BOARD ASSY INCLUDES:		
-172	131-0608-00		31	.CONTACT, ELEC: 0.365 INCH LONG	22526	47357
-173	136-0252-00	B010100 B010149	6	.SOCKET, PIN TER.0.145 INCH LONG	00779	2-330808-7
	136-0350-00	B01050	2	.SOCKET, PLUG-IN: 3 PIN, LO PROFILE	80009	136-0350-00
-174	214-1731-01		1	...HEAT SINK, ELEC: TRANSISTOR (ATTACHING PARTS)	80009	214-1731-01
-175	211-0012-00	B10100 142324	1	.SCREW, MACHINE: 4-40 X 0.375 INC , PNH STL	83385	OBD
	211-0016-00	B142325	1	.SCREW, MACHINE: 4-40 X 0.625 INC W , PNH STL	83385	OBD
	210-0851-00	XB142325	1	.WASHER, FLAT: 0.119 ID X 0.375 INCH OD, STL	12327	OBD
-176	210-0935-00		1	.WASHER, NONMETAL FIBER, 0.14 ID X 0.375"OOD	74921	OD
-177	210-0586-00		1	.NUT, PLAIN, EXT W 4-40 X 0.25 INCH, STL ---*---	78189	BD
	407-1837-00	B142325	1	.BRACKET, CKT CRD: (ATTACHING PARTS)	80009	407-1837-00
	212-0522-00	X142325	1	.SCREW, MACHINE: 10-32 X 2.50, HEX HD STL	83385	OBD
	210-0805-00	XB42325	1	.WASHER, FAT: 0.204 ID X 0.438 INCH OD, STL	12327	OBD
	166-0457-00	XB142325	2	..INSUL SLVG, ELEC: 0.19 ID X 1.875" LONG MYLAR	80009	166-0457-00
	220-0410-00	XB142325	1	...NUT, EXTENDED WA:10-32 X 0.375 INC, STL ---*---	83385	OBD
-178	214-1292-00		2	..HEAT SINK, ELEC: TRANSISTOR	05820	205-AB
-179	344-0154-00		4	.CLIP, ELECTRICAL: FOR 0.25 INCH DIA FUSE	80009	344-0154-00
-180	-----		1	.SW, THERMOSTATIC: (SEE S1000 EPL) (ATTACHING PARTS)		
-181	211-0008-00		2	.SCREW, MACHINE: 4-40 X 0.25 INCH, PNH STL	83385	OBD
-182	210-0586-00		2	.NUT, PLAIN, EXT W: 4-40 X 0.25 INCH, STL ---*---	78189	OBD
-183	-----		1	.TRANSFORMER: (SEE T801 EPL) (ATTACHING PARTS)		
-184	212-0522-00			.SCREW, MACHINE: 10-32 X 2.50", HEX HD STL	83385	OBD
-185	210-0812-00		2	.WASHER, NONMETAL: #10 , FIBER	86	445 OBD
-186	166-0457-00		2	.INSUL SLVG, ELEC: 0.19 ID X 1.875"LONG MYLAR	80009	166-0457-00
-187	212-0023-00		2	.SCREW, MACHINE: 8-32 X 0.375 INCH, PNH STL	83385	OBD
-188	210-0804-00		2	.WASHER, FLAT: 0.17 ID X 0.375 INCH OD, STL	12327	OBD
-189	407-0921-00		1	.BRKT, XFMR MTG: ---*---	80009	407-0921-00
-190	441-0993-01		1	.CHASSIS, SCOPE-POWER SUPPLY LW VOLTAGE	80009	441-0993-01

Mechanical Parts List - 7623A/R7623A Service

Fig. & Index No.	Tektronix Part No.	Serial/Model No Eff Dscont	Qty	1 2 3 4 5 Name & Description	Mfr Code	Mfr Part Number
4-191	407-0973-00		1	BRACKET, CONN: (ATTACHING PARTS)	80009	407-0973-00
	211-0504-00		2	SCREW, MACHINE: 6-32 X 0.25 INCH, PNH STL ---*---	81385	OBD
-192	-----		1	CKT BOARD ASSY: LOGIC(SEE A2 EPL)		
	-----		-	.CKT BOARD ASSY INCLUDES:		
-193	131-0566-00		1	.LINK, TERM. CONNE:0.086 DIA X 2.375 INCH L	0000L	ERD-18T0
-194	136-0235-00		1	.SOCKET, PLUG-IN: 6 CONTACT, ROUND	71785	133-96-12-062
-195	136-0252-00	B01000 B010149	24	.SOCKET, PIN TER: 0.188 INCH LON	22526	75060
	136-0350-00	B010150	8	.SOCKET, PLUG-IN:3 PIN, LOW PROFILE	80009	136-0350-00
-196	136-0260-02		1	.SOCKET, PLUG-IN: 16 CONTACT ,CLEARANCE	01295	C931602
-197	136-0263-03	B010100 B111714	33	.SOCKET, PIN TERM: FOR 0.025 INCH SU ARE PIN	00779	86250-2
	136-0263-04	B111715	33	.SOCKET, PIN TER: FOR 0.025 INCH SQUARE PIN	22526	75377-001
-198	136-0269-02		3	.SOCKET, PLUG-IN: 14 CONTACT, LO CLEARANCE	01295	C931402
-199	214-0579-00		4	.TERM., TEST PT: 0.40 INCH LONG	80009	214-0579-00
-200	-----		1	CKT BOARD ASSY: MAIN INTERFACE(SEE A EPL) (ATTACHING PARTS)		
-201	213-0034-00		9	SCR, TPG, THD CG: 4-40 X 0.188 INCH, PNH STL ---*---	83385	OBD
	-----		-	.CKT BOARD ASSY INCLUDES:		
-202	131-0608-00		86	.CONTACT, ELEC: 0.365 INCH NG	22526	47357
	131-0592-00		24	.CONTACT, ELEC: 0.885 INCH LONG	22526	47353
	131-0591-00		33	.CONTACT, ELEC: 0.835 INCH LONG	252	47352
	131-0589-00		4	.CONTACT, ELEC: 0.46 INCH LONG	22526	47350
-203	129-0308-00		3	.POST, ELE- H: HEX , .25 X 0.465 INCH LONG (ATTACHING PARTS)	80009	129-0308-00
-204	211-0008-00		1	.SCREW, MACHINE: 4-40 X 0.25 INCH, PNH STL ---*---	83385	OBD
-205	129-0308-00		1	.POST, ELEC-EC: H., 0.25 X 0.465 INCH LG (ATTACHING PARTS)	80009	129-0308-00
	211-0008-00		1	.SCREW, MACHINE: 4-40 X 0.25 INCH, PNH STL	83385	OBD
-206	210-0803-00		1	.WASHER, FLAT: 0.15 ID X 0.375 INC OD, STL ---*---	12327	OBD
	-----		-	.LINK, TERM. CONNE : J-SHAPE	80009	131-0804-00
-207	131-0804-00		1	.LINK, TERM. CONNE: J-SHAPE, .90X0.82 X 0.312"	80009	131-0805-00
-208	131-0805-00		2	.CONNECTOR BODY, : CKT CD MT, 3 PRONG	80009	131-1003-00
-209	131-1003-00		2	.CONTACT, ELEC: 0.178 INCH LONG	00779	1-332095-2
-210	136-0252-01		2	.CONNECTOR, RCPT, : PLUG-IN CKT BD, 70 CONTACT	80009	131-0767-
08				(ATTACHING PARTS FOR EACH)		
-211	213-0232-00		2	.SCR, TPG, THD FOR: 2-32 X 0.312 INCH, PNH STL ---*---	83385	OBD
	-----		-	.EACH CONNECTOR INCLUDES:		
-212	200-0950-00		2	.COVER, EEC CONN: PLASTIC	80009	200-0950-00
-213	131-0726-00		33	.CONTACT, ELEC STRAIGHT	80009	131-0726-00
-214	131-0727-00		33	.CONTACT, ELEC: OFFSET	80009	131-0727-00
-215	131-0899-00		4	.CONTACT, ELEC: 0.048 X 0.006 INCH THK	80009	131-0899-00
-216	204-0365-00		1	.BODY, CONNECTOR: PLUG-IN CIRCUIT CARD	80009	204-0365-00
	131-0767-07		1	.CONNECTOR, RCPT, : PLUG-IN CKT BD, 70 CONTACT	80009	131-0767-
07				(ATTACHING PARTS)		
-217	213-0232-00		2	.SCR, TPG, THD FOR: -3Z X0.312 INC, PH STL	83385	OBD
-218	210-0906-00		1	.WASHER, NONMETAL: FIBER, 0.125 ID X 0.203"OD ---*---	86928	OBD
	-----		-	.CONNECTOR INCLUDES:		
-219	200-0950-00		2	.COVER, ELEC CON: PLASTIC	80009	200-0950-00
-220	131-0726-00		35	.CONTACT, ELEC: STRAIGHT	80009	131-0726-00
-221	131-0727-00		35	.CONTACT, ELEC: OFFSET	80009	131-0727-00
-222	204-0365-02		1	.BODY, CONNECTOR: PLUG-IN CIRCUIT CARD	80009	204-0365-02
-223	-----		1	CKT BOARD ASSY: (SEE A15 EPL) (ATTACHING PARTS)		
-224	211-0008-00		2	.SCREW, MACHINE: 4-40 X 0.25 INCH, PB STL	83385	OBD
-225	351-0213-00		2	.GUIDE-POST, LOCK: 0.285 INCH LONG ---*---	80009	351-0213-00
	-----		-	.CKT BOARD ASSY INCLUDES:		
-226	131-0787-00		8	.CONTACT, ELEC: 0.64 INCH LONG	22526	47359
-227	344-0147-00		2	.CLIP, SPR, TNSN: CIRCUIT CARD MOUNTING (ATTACHING PARTS FOR EACH)	80009	344-0147-00
-228	210-0406-00		1	.NUT, PLAIN, HEX.4-40 X 0.188 INC, BRS	73743	2XI2161-40Z
-229	210-0054-00		1	.WASHER, LOCK: SPLIT, 0.118 ID X .Z212"OD STL	83385	OBD

Mechanical Parts List - 7623A/R7623A Service

Fig. & Index No.	Tektronix Part No.	Serial/Model No Eff Dscont	Qty	1 2 3 4 5 Name & Description	Mfr Code	Mfr Part Number
4-230	214-1568-00		1	.PIN, GUIDE: ---*---	80009	214-1568-00
-231	386-1558-00		2	.SPACER, CKT CARD: PLASTIC	80009	386-1558-00
-232	214-0579-00		1	.TERM., TEST PT: 0.40 INCH LONG	80009	214-0579-00
-233	-----		1	CKT BOARD ASSY: VERTICAL INTERFACE(SEE A4 EPL) (ATTACHING PARTS)		
'234	211-0008-00		2	SCREW, MACHINE: 4-40 X 0.25 INCH, PH STL	83385	OBD
	-----		-	.CKT BOARD ASSY INCLUDES:		
-235	136-0252-04	B010100 B010149	31	.SOCKET, PIN TERM: 0.188 INCH LON	22526	75060
	136-0254-04	B010150	22	.CONTACT, ELEC: 0.188 INCH LONG	22526	75060
	136-0350-00	B010150	3	.SOCKET, PLUG-IN: 3 PN PIN, LOW PROFILE	80009	136-0350-00
-236	136-0263-04		18	.SOCKET, PIN TERM: FOR 0.025 INCH SPARE PIN	22526	75377-001
-237	-----		1	CKT BOARD ASSY: TRIGGER SELECT(SEE A3 EPL) (ATTACHING PARTS)		
-238	211-0008-00		2	SCREW, MACHINE: 4-40 X 0.25 INCH, PNH STL	83385	ORD
	-----		-	.CKT BOARD ASSY INCLUDES:		
	131-0589-00		4	.CONTACT, ELEC: 0.46 INC LONG	22526	47350
-239	136-0252-04	B010000 B010149	15	.SOCKET, PIN TERM: 0.188 INCH LON	22526	75060
	136-0350-00	B010150	5	.SOCKET, PLUG-IN: 3 PIN, OW PROFILE	80009	136-0350-00
-240	136-0260-01		1	.SOCKET, PLUG-IN: 16 CONTACT, RECT SHAPE	71785	133-51-02-075
-241	136-0263-03		16	.SOCKET, PIN TERM: FOR 0.025 INCH SQUARE PIN	00779	86250-2
-242	131-0800-00		2	CONTACT, ELEC: PLUG-IN GROUND (ATTACHING PARTS FOR EACH)	80009	131-0800-00
-243	211-0008-00		2	SCREW, MA4HINE: 4-40 X 0.25 INCH, PNH STL	83385	OBD
-244	210-0586-00		2	NUT, PLAIN, EXT W: 4-40 X 0.25 INCH, STL	78189	OBD
	-----		---	---		
-245	131-0930-00		2	CONTACT, ELEC: PLUG-IN GROUND (ATTACHING PARTS FOR EACH)	80009	131-0930-00
-246	211-0008-00		1	SCREW, MACHINE: 4-40 X 0.25 INCH, PNH STL	83385	OBD
-247	210-0586-00		1	NUT, PLAIN, EXT W: 4-40 X 0.25 INCH, STL	78189	OBD
	-----		---	---		
-248	131-0799-00		2	CONTACT, ELEC: (ATTACHING PARTS FOR EACH)	80009	131-0799-00
-249	211-0008-00		1	SCREW, MACHINE: 4-40 X 0.25 INCH, PNH STL	83385	OD
-250	210-0586-00		1	NUT, PLAIN, EXT W: 4-40 X 0.25 INCH, STL	78189	OBD
	-----		---	---		
-251	351-0790-00		1	GUIDE, CARD: 6.75 INCH LONG, PLASTIC (ATTACHING PARTS)	80009	351-0179-00
	211-0101-00		2	SCREW, MACHINE: 4-40 X 0.25" 100 DEG, FLH STL	83385	OBD
	-----		---	---		
-252	136-0617-00		1	CRT SOCKET, ASSEMBLY:	80009	136-0617-00
-253	136-0304-02		1	.SOCKET, PLG-IN: CRT, 14 PIN SOCKET, W/PINS	80009	136-0304-02
-254	200-0917-01		1	.COV, ELECTRON TU: 2.052 OD X 0.291" TUK, PLSTC	80009	200-0917-01
-255	367-0117-00		1	.PULL, SOC, PL-IN:	80009	367-0117-00
-256	343-0254-00		1	.CLAMP, CRT SKT:	80009	343-0254-00
-257	131-0707-00		7	.CONTACT ELEC: .48"L, 22-26 A-G WIRE	22526	47439
-258	131-0621-00		6	.CONTACT, EEC: 0.577"L, 22-26 AWG WIRE	22526	46231
-259	348-0012-00		1	.GROMMET, RUBBER: 0.625 INCH DIA	72653	1043-1M
-260	352-0161-05		1	.CONN BODY, PL, EL: 3 WIRE GREEN	80009	352-0161-05
-261	352-0162-09		1	.CONN BODY, PL, EL: 4 WIRE WHITE	80009	352-0162-09
-262	352-0205-00		1	.CONN BODY, PL, EL: 9 WIRE BLACK	80009	352-0205-00
-263	179-1825-00		1	WIRING HARNESS, : VERTICAL SIGNAL	80009	179-1825-00
	131-0707-00		1	.CONTACT, ELEC: 0.48"L, 22-26 A-G WIRE	22526	47439
	131-0708-00		2	.CONTACT, ELEC: 0.48"L, 28-32 AWG WIRE	22526	47437
-264	210-0774-00		2	.EYELET, METALLIC: 0.152 OD X 0.245 INCH L, BDS	80009	210-0774-00
-265	210-0775-00		2	.EYELET, METALLIC: 0.126 OD X 0.23 INCH L, BRS	80009	210-0775-00
	352-016-09		1	.CONN BODY, PL, EL: 4 WIRE WHITE	80009	352-0162-09
	179-1826-00		1	WIRING HARNESS, : SWEEP GATE	80009	79-1826-00
	131-0707-00		8	.CONTACT, ELEC: 0.48"L, 22-26 AWG WIRE	22526	47439
	131-0708-00		8	.CONTACT, ELEC: 0.48"L, 28-32 A-G WIRE	22526	47437
-266	352-0166-03		1	.CONN BODY, PL, EL: WIRE ORANGE	80009	352-0166-03
	179-1828-01		1	WIRING HARNESS: COAX	80009	179-1828-01
	131-0707-00		2	.CONTACT, ELEC: 0.48"L, 22-26 AW WIRE	22526	47439
	131-0708-00		2	.CONTACT, ELEC: 0.48"L, 28-32 AWG WIRE	22526	47437
-267	352-0169-05		1	.CONN BODY, PL, EL: 2 WIRE GREEN	80009	352-0169-05
	352-0169-09		1	.CONN BODY, PL, EL: 2 WIRE WHITE	80009	32-0169-09
	131-0621-00		6	CONTACT, ELEC: 0.577"L, 22-26 AWG WIRE	22526	4231
	131-0707-00		393	CONTACT, ELEC: 0.48"L, 22-26 AWG WIRE	22526	47439

Mechanical Parts List - 7623A/R7623A Service

Fig. & Index No.	Tektronix Part No.	Serial/Model No Eff Dscont	Qty	1 2 3 4 5 Name & Description	Mfr Code	Mfr Part Number
4-	131-0708-00		27	CONTACT, ELEC: 0.48"L, 28-32 AWG WIRE	22526	47437
-268	131-0861-00		4	CONTACT, ELEC: QUICK DISCONNECT	00779	42617-2
-269	131-1538-00		4	CONTACT, ELEC: CRIMP-ON, 22-26 AWG WIRE	22526	75369-002
	210-0774-00		13	EYELET, METALLIC: 0.152 OD X 0.245 INCH L, BRS	80009	210-0774-00
	210-0775-00		13	EYELET, METALLIC: 0.126 OD X 0.23 INCH L, BRS	80009	210-0775-00
-270	175-0825-00		FT	WIRE, ELECTRICAL: 2 WIRE RIBBON	23499	TEK-175-0825-00
-271	175-0826-00		FT	WIRE, ELECTRICAL: 3 WIRE RIBBON	08261	TE-175-0826-00
-272	175-0827-00		FT	WIRE, ELECTRICAL: 4 WIRE RIBBON	08261	TEK-175-0827-00
-273	175-0828-00		FT	WIRE, ELECTRICAL: 5 WIRE RIBBON	23499	TEK-175-0828-00
-274	175-0829-00		FT	WIRE, ELECTRICAL: 6 WIRE RIBBON	83501	TEK-175-0829-00
-275	175-0830-00		FT	WIRE, ELECTRICAL: 7 WIRE RIBBON	08261	TEK-175-0830-00
-276	175-0831-00		FT	WIRE, ELECTRICAL: 8 WIRE RIBBON	08261	TEK-175-0831-00
	175-0857-00		FT	WIRE, ELECTRICAL: B WIRE RIBBON	80009	175-0857-00
-277	175-0832-00		FT	WIRE, ELECTRICAL: 9 WIRE RIBBON	23499	TEX-175-0832-00
-278	175-0833-00		FT	WIRE, ELECTRICAL: 10 WIRE RIBBON	23499	TEK-175-0833-00
	175-0855-00		FT	WIRE, ELECTRICAL: 10 WIRE RIBBON	23499	TEK-175-0855-00
-279	200-1075-00		4	COVER, ELEC CONN: PLASTIC	00779	1-480435-0
	352-0161-00		4	CONN BODY, PL, EL: 3 WIRE BLACK	80009	352-0161-00
	352-0161-02		1	HOLDER, TERM, CON: 3 WIRE, RED	80009	352-0161-02
	352-0161-03		1	CONN BODY, PL, EL: 3 WIRE ORANGE	80009	352-0161-03
	352-0161-05		1	CONN BODY, PL, EL: 3 WIRE GREEN	80009	352-0161-05
	352-0161-06		2	CONN BODY, PL, EL: 3 WIRE BLUE	80009	352-0161-06
	352-0161-08		1	CONN BODY, PL, EL: 3 WIRE GRAY	80009	352-0161-08
	352-0161-09		2	HOLDER, TERM, CON: 3 WIRE, WHITE	80009	352-0161-09
	352-0162-00		4	CONN BODY, PL, EL: 4 WIRE BLACK	80009	352-0162-00
	352-0162-01		4	CONN BODY, PL, EL: 4 WIRE BROWN	80009	352-0162-01
	352-0162-09		2	HOLDER, TERM, CON: 4 WIRE, WHITE	80009	352-0162-09
-280	352-0163-00		1	CONN BODY, PL, EL: 5 WIRE BLACK	80009	352-0163-00
	352-0163-01		2	CONN BODY, PL, EL: 5 WIRE BROWN	80009	352-0163-01
	352-0163-05		1	CONN BODY, PL, EL: 5 WIRE GREEN	80009	352-0163-05
	352-0163-06		2	CONN BODY, PL, EL: 5 WIRE BLE	80009	352-0163-06
	352-0163-08		3	CONN BODY, PL, EL: 5 WIRE GRAY	80009	352-0163-08
-281	352-0164-01		2	CONN BODY, PL, EL: 6 WIRE BROWN	80009	352-0164-01
	352-0164-09		1	HOLDER, TERM, CON: 6 WIRE, WHITE	80009	352-0164-09
-282	352-0165-08		1	HOLDER, TERM, CON: 7 WIRE, GRAY	80009	352-0165-08
	352-0166-00		4	CONN BODY, PL, EL: 8 WIRE BLACK	80009	352-0166-00
	352-0166-01		2	CONN BODY, PL, EL: 8 WIRE BROWN	80009	352-0166-01
	352-0166-03		2	CONN BODY, PL, EL: 8 WIRE ORANGE	80009	352-0166-03
-283	352-0167-00		2	CONN BODY, PL, EL: 9 WIRE BLACK	80009	352-0167-00
	352-0167-04		2	HOLDER, TERM, CON: 9 WIRE, YELLOW	80009	352-0167-04
	352-0167-05		2	CONN BODY, PL, EL: 9 WIRE GREEN	80009	352-0167-05
-284	352-0168-00		2	CONN BODY, PL, EL: 10 WIRE B- ACK	80009	352-0168-00
	352-0168-02		3	CONN BODY, PL, EL: 10 WIRE RED	80009	352-0168-02
	352-0168-05		2	CONN BODY, PL, EL: 10 WIRE GREEN	80009	352-0168-05
	352-0168-07		2	CONN BODY, PL, EL: 10 WIRE VIOLET	80009	352-0168-07
	352-0169-00	B010100 B059999	3	CONN BODY, PL, EL: 2 WIRE BLACK	80009	352-0169-00
	352-0169-00	B060000	2	CONN BODY, PL, EL: 2 WIRE BLACK	80009	352-0169-00
	352-0169-01		1	CONN BODY, PL, EL: 2 WIRE BROWN	80009	352-0169-01
	352-0169-02		1	CONN BODY, PL, EL: 2 WIRE RED	80009	352-0169-02
	352-0169-04		1	CONN BODY, PL, EL: 2 WIRE YEL	80009	352-0169-04
	352-0169-08		4	HOLDER, TERM, CON: 2 WIRE, GRAY	80009	352-0169-08
	352-0169-09		2	CONN BODY, PL, EL: 2 WIRE WHITE	80009	352-0169-09
-285	352-0171-00		3	CONN BODY, PL, EL: 1 WIRE BLACK	80009	352-0171-00
	352-0171-03		2	HOLDER, TERM, CON: 1 WIRE, ORANGE	80009	352-0171-03
	352-0205-00		1	CONN BODY, PL, EL: 9 WIRE BLACK	80009	352-0205-00

**APPENDIX A
REFERENCES**

The following is a list of applicable references that are available to the operator and maintenance personnel of Oscilloscope OS-262(P)/U:

DA Pam 310-4	Index of Technical Manuals, Technical Bulletins, Supply Manuals (Types 7, 8, and 9), Supply Bulletins, and Lubrication Orders.
DA Pam 3107	US Army Index of Modification Work Orders.
SB 38-100	Preservation, Packaging, Packing and Marking Materials, Supplies, and Equipment Used by the Army.
SC 5180-91-CL-R07	Tool, Electronic Equipment T-105/G.(NSN 5180-00-610-8177) (Line Item W37388)
SM 11-4-5180-S05	Tool Equipment TE-50B.
TB 43-0118	Field Instructions for Painting and Preserving Electronics Command Equipment Including Camouflage Pattern Painting of Electrical Equipment Shelters.
TM 38-750	The Army Maintenance Management System (TAMMS).
TM 740-90-1	Administrative Storage of Equipment.
TM 750-244-2	Procedures for Destruction of Electronics Materiel to Prevent Enemy Use (Electronics Command).

APPENDIX D MAINTENANCE ALLOCATION

Section I. INTRODUCTION

D-1. General

This appendix provides a summary of the maintenance operations for OS-262(P)/U. It authorizes categories of maintenance for specific maintenance functions on repairable items and components and the tools and equipment required to perform each function. This appendix may be used as an aid in planing maintenance operations.

D-2. Maintenance Function

Maintenance functions will be limited to and defined as follows:

a. Inspect. To determine the serviceability of an item by comparing its physical, mechanical, and/or electrical characteristics with established standards through examination.

b. Test. To verify serviceability and to detect incipient failure by measuring the mechanical or electrical characteristics of an item and comparing those characteristics with prescribed standards.

c. Service. Operations required periodically to keep an item in proper operating condition, i. e., to clean (decontaminate), to preserve, to drain, to paint, or to replenish fuel, lubricants, hydraulic fluids, or compressed air supplies.

d. Adjust. To maintain, within prescribed limits, by bringing into proper or exact position, or by setting the operating characteristics to the specified parameters.

e. Align. To adjust specified variable elements of an item to bring about optimum or desired performance.

f. Calibrate. To determine and cause corrections to be made or to be adjusted on instruments or test measuring and diagnostic equipments used in precision measurement. Consists of comparisons of two instruments, one of which is a certified standard of known accuracy, to detect and adjust any discrepancy in the accuracy of the instrument being compared.

g. Install. The act of emplacing, seating, or fixing into position an item, part, module (component or assembly) in a manner to allow the proper functioning of the equipment or system.

h. Replace. The act of substituting a serviceable like type part, subassembly, or module (component or assembly) for an unserviceable counterpart.

i. Repair. The application of maintenance services (inspect, test, service, adjust, align, calibrate, replace) or other maintenance actions (welding,

grinding, riveting, straightening, facing, remachining, or resurfacing) to restore serviceability to an item by correcting specific damage, fault, malfunction, or failure in a part, subassembly, module (component or assembly), end item, or system. This function does not include the trial and error replacement of running spare type items such as fuses, lamps, or electron tubes.

j. Overhaul. That maintenance effort (service/action) necessary to restore an item to a completely serviceable/operational condition as prescribed by maintenance standards (i. e., DMWR) in appropriate technical publications. Overhaul is normally the highest degree of maintenance performed by the Army. Overhaul does not normally return an item to like new condition.

k. Rebuild. Consists of those services/actions necessary for the restoration of unserviceable equipment to a like new condition in accordance with original manufacturing standards. Rebuild is the highest degree of materiel maintenance applied to Army equipment. The rebuild operation includes the act of returning to zero those age measurements (hours, miles, etc.) considered in classifying Army equipments components.

D-3. Column Entries

a. Column 1, Group Number. Column 1 lists group numbers, the purpose of which is to identify components, assemblies, subassemblies, and modules with the next higher assembly.

b. Column 2, Component/Assembly Column 2 contains the noun names of components, assemblies, subassemblies, and modules for which maintenance is authorized.

c. Column 3, Maintenance Functions. Column 3 lists the functions to be performed on the item listed in column 2. When items are listed without maintenance functions, it is solely for purpose of having the group number in the MAC and RPSTL coincide.

d. Column 4, Maintenance Category. Column 4 specifies, by the listing of a "work time" figure in the appropriate subcolumn(s), the lowest level of maintenance authorized to perform the function listed in column 3. This figure represents the active time required

to perform that maintenance function at the indicated category of maintenance. If the number or complete of the tasks within the listed maintenance function vary at different maintenance categories, appropriate "work time" figures will be shown for each category. The number of task-hours specified by the "work time" figure represents the average time required to restore an item (assembly, subassembly, component, module, end item or system) to a serviceable condition under typical field operating conditions. This time includes preparation time, troubleshooting time, and quality assurance/quality control time in addition to the time required to perform the specific tasks identified for the maintenance functions authorized in the maintenance allocation chart. Subcolumns of column 4 are as follows:

- C-Operator/Crew
- O-Organizational
- F-Direct Support
- H-General Support
- D-Depot

e. *Column 5, Tools and Equipment.* Column 5 specifies by code, those common tool sets (not individual tools) and special tools, test, and support equipment required perform the designated function.

f. *Column 6, Remarks.* Column 6 contains an alphabetic code which leads to the remark in section IV, Remarks, which is pertinent to the item opposite the

particular code.

D-4. Tool and Test Equipment Requirements (Sec. III)

a. *Tool or Test Equipment Reference Code.* The numbers in this column coincide with the numbers used in the tools and equipment column of the MAC. The numbers indicate the applicable tool or test equipment for the maintenance functions.

b. *Maintenance Category.* The codes in this column indicate the maintenance category allocated the tool or test equipment.

c. *Nomenclature.* This column lists the noun name and nomenclature of the tools and test equipment required to perform the maintenance functions.

d. *National NATO Stock Number.* This column lists the National NATO stock number of the specific tool or test equipment.

e. *Tool Number.* This column lists the manufacturer's part number of the tool followed by the Federal Supply Code or manufacturers (digit) in parentheses.

D-5. Remarks (Sec. IV)

Not Applicable.

(Next printed page is D-3)

SECTION II MAINTENANCE ALLOCATION CHART FOR OSCILLOSCOPE OS-262 (P)/U

(1) GROUP NUMBER	(2) COMPONENT ASSEMBLY	(3) MAINTENANCE FUNCTION	(4) MAINTENANCE CATEGORY					(5) TOOLS AND EQUIPMENT	(6) REMARKS
			C	O	F	H	D		
00	OSCILLOSCOPE OS-262(P)/U	Inspect Test Calibrate Repair Overhaul		0.1		1.0 2.0 1.0		1 thru 20 1 thru 20 16 1 thru 20	
01	Circuit Card Assembly (A1)	Inspect Test Replace Repair				0.1 0.5 0.2 1.0	16	16 16,18,19 16 16	
02	Circuit Card Assembly (A)	Inspect Test Replace Repair				0.1 0.5 0.2 1.0		16 9,12,16 18,19,20 16 16	
03	Circuit Card Assembly (A3)	Inspect Test Replace Repair				0.1 0.5 0.2 1.0		16 9,12,16 18,19,20 16 16	
04	Circuit Card Assembly (A)	Inspect Test Replace Repair				0.1 0.5 0.2 1.0		16 9,12,16 18,19,20 16 16	
05	Circuit Card Assembly (MA)	Inspect Test Replace Repair				0.1 0.5 0.2 1.0		16 9,12,16 20 16 16	
06	Circuit Card Assembly (A6)	Inspect Test Replace Repair				0.1 0.5 0.2 1.0		16 9,16,18 19 16 16	
07	Sub-Panel Assembly, Rear (MP1)	Inspect Test Repair Repair				0.1 0.5 0.5 1.0		16 9,10,12 16,19,20 16 16	
08	Circuit Card Assembly (A2)	Inspect Test Replace Repair				0.1 0.5 0.2 1.0		16 16,18,19 16 16	
09	Circuit Card Assembly (A13)	Inspect Test Replace Repair				0.1 0.5 0.2 1.0		16 16,18,19 16 16	
10	Circuit Card Assembly (A4)	Inspect Test Replace Repair				0.2 0.5 0.2 1.0		16 2,3,5,6 10,11,12 13,16,19 16 16	
11	Power Supply, High Voltage (PS1)	Inspect Test Repair				0.1 0.5 0.5		16 16,18,19 16	
1101	Circuit Card Assembly (PS\$1A)	Inspect Test Replace Repair				0.1 0.5 0.5 1.0		16 16,18,19 16 16	

*The subcolumns are as follows:

- C - operator/crew
- O - organizational
- F - direct support
- H - general support
- D- depot

SECTION II MAINTENANCE ALLOCATION CHART FOR OSCILLOSCOPE OS-262 (P)/U

(1) GROUP NUMBER	(2) COMPONENT ASSEMBLY	(3) MAINTENANCE FUNCTION	(4) MAINTENANCE CATEGORY					(5) TOOLS AND EQUIPMENT	(6) REMARKS
			C	O	F	H	D		
1102	Circuit Card Assembly (PSA9)	Inspect				0.1			
		Test				0.5		16,18,19	
		Replace				0.2		16	
11 03	Circuit Card Assembly (PSA10)	Repair				1.0		16	
		Inspect				0.1		16	
		Test				0.5		16,18,19	
12	Power Supply, Low Voltage (PS2)	Replace				0.2		16	
		Repair				1.0		16	
		Inspect				0.1		16	
1201	Circuit Card Assembly (PS2A11)	Test				0.5		16,18,19	
		Inspect				0.1		16	
		Test				0.5		16,18,19	
13	Circuit Card Assembly A(17)	Replace				0.2		16	
		Repair				1.0		16	
		Inspect				0.1		16	
		Test				0.5		16,18	
		Replace				0.2		16	
		Repair				0.5		16	

SECTION III MAINTENANCE ALLOCATION CHART FOR OSCILLOSCOPE OS-262 (P)/U

(1) TOOL OR TEST EQUIPMENT REF CODE	(2) MAINTENANCE LEVEL	(3) NOMENCLATURE	(4) NATIONAL/NATO STOCK NUMBER	(5) TOOL NUMBER
1	H, D	BNC TO PIN JACK CABLE, EQUIVALENT TO TEKTRONIX PART NO. 175-1178-00		
2	H, D	CABLE, RG-58/U, 18 IN, EQUIVALENT TO TEKTRONIX PART NO. 012-0076-00	6625-00-916-8025	
3	H, D	CABLE, RF-58/U, 42 IN, EQUIVALENT TO TEKTRONIX PART NO. 012-00570-01	6625-00-498-4834	
4	H, D	CALIBRATION FIXTURE, EQUIVALENT TO TEKTRONIX PART NO. 057-0587-01	6625-00-115-6711	
5	H, D	GENERATOR, LOW-FREQUENCY SIGNAL, EQUIVALENT TO TEKTRONIX FG502		
6	H, D	GENERATOR, MEDIUM-FREQUENCY, EQUIVALENT TO TEKTRONIX 191	6625-00-957-0421	
7	H, D	GENERATOR, TIME MARK, EQUIVALENT TO TEKTRONIX 2901	6625-00-483-2619	
8	H, D	GR IN-LINE TERMINATION, EQUIVALENT TO TEKTRONIX PART NO. 017-0083-00	5985-00-087-4953	
9	H, D	OSCILLOSCOPE, TEST, SYSTEM, DUAL-TRACE, EQUIVALENT TO TEKTRONIX 7603	6625-00-106-9622	
10	H, D	AMPLIFIER, 2 EA EQUIVALENT TO TEKTRONIX 7A15A		
11	H, D	100X PROBE, EQUIVALENT TO TEKTRONIX P6009		
12	H, D	10X PROBE, EQUIVALENT TO TEKTRONIX P6053B		
13	H, D	TIME BASE, PLUG-IN, UNIT, EQUIVALENT TO TEKTRONIX 7B53A	6625-00-261-5139	
14	H, D	T CONNECTOR, EQUIVALENT TO TEKTRONIX PART NO. 103-0030-00		
15	H, D	TERMINATION, EQUIVALENT TO TEKTRONIX PART NO. 011-0049-01	5985-00-087-4954	
16	H, D	TOOLKIT, ELECTRONIC EQUIPMENT, TK-100/6	5180-00-605-0079	
17	H, D	AMPLIFIER, 2 EA, EQUIVALENT TO TEKTRONIX 718	6625-00-185-7817	
18	H, D	VOLTMETER, DC, (VOM), EQUIVALENT TO SIMPSON 262	6625-00-034-4865	
19	H, D	VOLTMETER, PRECISION DC, EQUIVALENT TO FLUKE 825A		
20	H, D	COMPARATOR, DIFFERENTIAL, EQUIVALENT TO TEKTRONIX TK-7A13	6625-00-707-3406	

By Order of the Secretaries of the Army, the Navy, and the Air Force:

BERNARD W. ROGERS
General, United States Army
Chief of Staff

Official:

J.C. PENNINGTON
Brigadier General, United States Army
The Adjutant General

EARL B. FOLWLER
Rear Admiral, United States Navy
Commander, Naval
Systems Command

Official:

F. M. ROGERS, *General, USAF*
Commander, Air Force Logistics
Command

DAVID C. JONES, *General USAF*
Chief of Staff

DISTRIBUTION:

Active Army

USASA (2)
COE (1)
TSG (1)
USAARENBD (1)
DARCOM (1)
TRADOC
OS Maj Cmd (4)
TECOM (2)
USACC (4)
MDW (1)
Armies (2)
Corps (2)
HISA (Ft Monmouth) (33)
Scv Colleges (1)
USASIGS (5)
USAADS (2)
USAFAS (2)
USAARMS (2)
USAIS (2)

USAES (2)
USAICS ()
MAAG (1)
USARMIS (1)
USAERDAA(1)
USAERDAW(1)
Instls (2) except
Ft Gordon (10)
R Huachuca (10)
Ft Carson (5)
Ft Richardson (ECOM Ofc) (2)
LBAD (14)
SAAD (30)
TOAD (14)
SHAD (3)
Ft Gillem (10)
ag FLDMS (1)

NG: None

USAR: None

For explanation of abbreviations used, see AR 310-50.

***U.S. GOVERNMENT PRINTING OFFICE: 1994-300-421/82703**

DIAGRAMS AND CIRCUIT BOARD ILLUSTRATIONS

Symbols and Reference Designators

Electrical components shown on the diagrams are in the following units unless noted otherwise:

- Capacitors = Values one or greater are in picofarads (pF)
- Values less than one are in microfarads (μF).
- Resistors = Ohms (Ω).

Symbols used on the diagrams are based on ANSI Standard Y32.2-1970.

Logic symbology is based on ANSI Y32.14-1973 in terms of positive logic. Logic symbols depict the logic function performed and may differ from the manufacturer's data.

The following prefix letters are used as reference designators to identify components or assemblies on the diagrams.

A	Assembly, separable or repairable (circuit board, etc.)	H	Heat dissipating device (heat sink, heat radiator, etc.)	RT	Thermistor
AT	Attenuator, fixed or variable	HR	Heater	S	Switch
B	Motor	HY	Hybrid circuit	T	Transformer
BT	Battery	J	Connector, stationary portion	TC	Thermocouple
C	Capacitor, fixed or variable	K	Relay	TP	Test point
CB	Circuit breaker	L	Inductor, fixed or variable	U	Assembly, inseparable or non-repairable (integrated circuit, etc.)
CR	Diode, signal or rectifier	LR	Inductor/resistor combination	V	Electron tube
DL	Delay line	M	Meter	VR	Voltage regulator (zener diode, etc.)
DS	Indicating device (lamp)	P	Connector, movable portion	Y	Crystal
E	Spark Gap	Q	Transistor or silicon-controlled rectifier	Z	Phase shifter
F	Fuse	R	Resistor, fixed or variable		
FL	Filter				

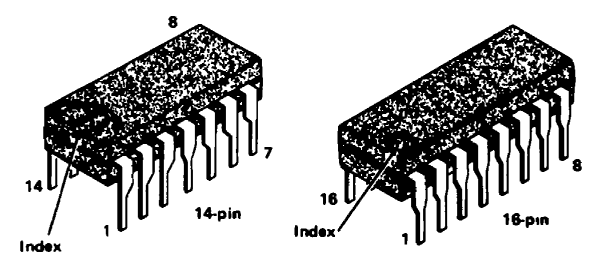
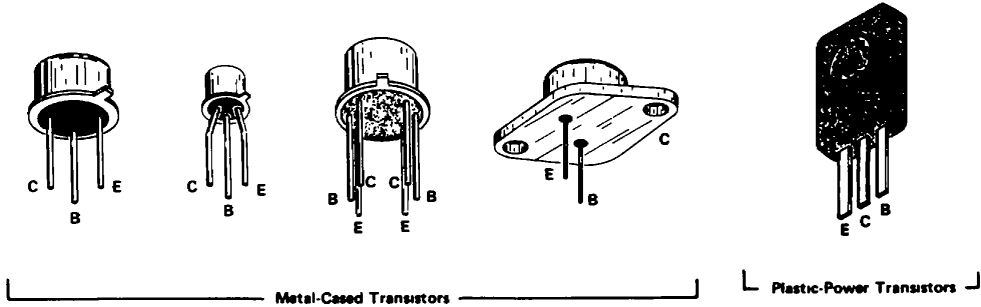
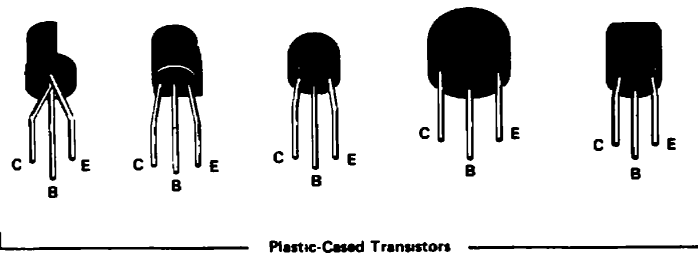
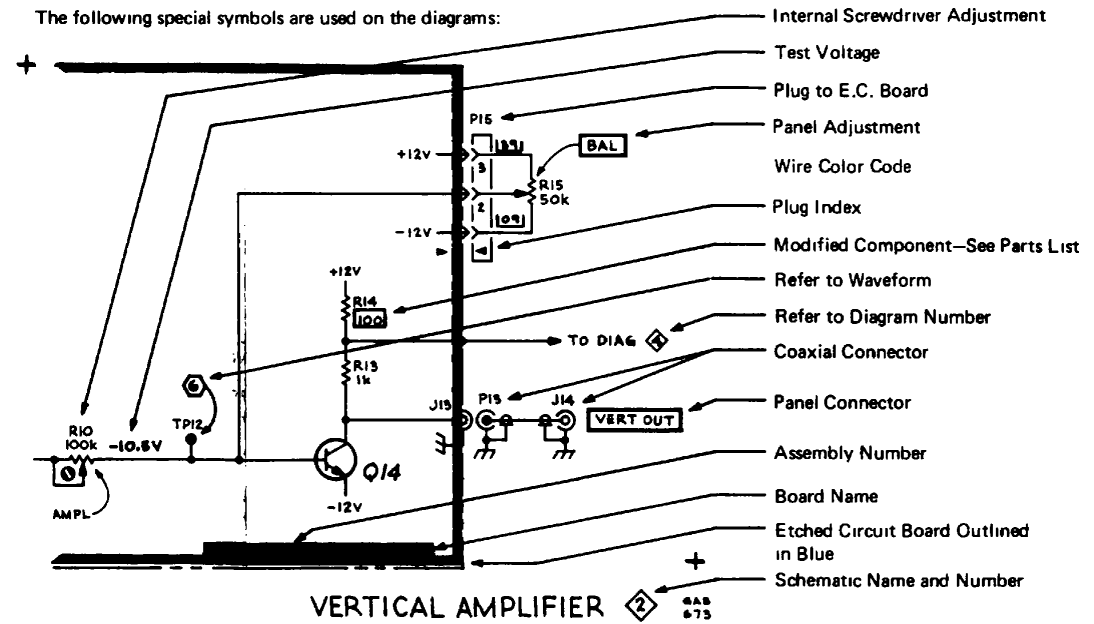

Figure 8-1. Semiconductor Lead configurations.

ⓐ



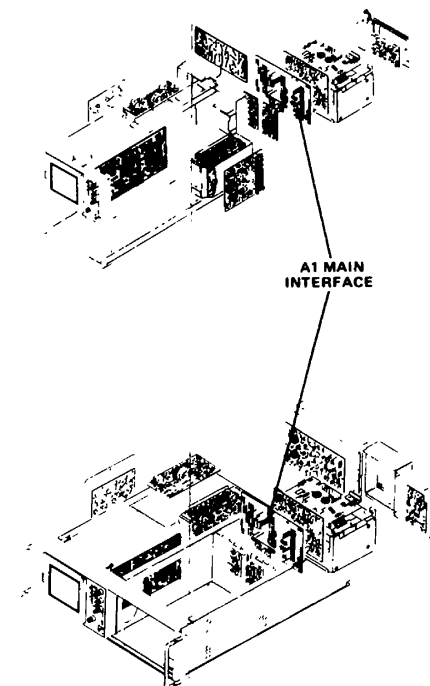
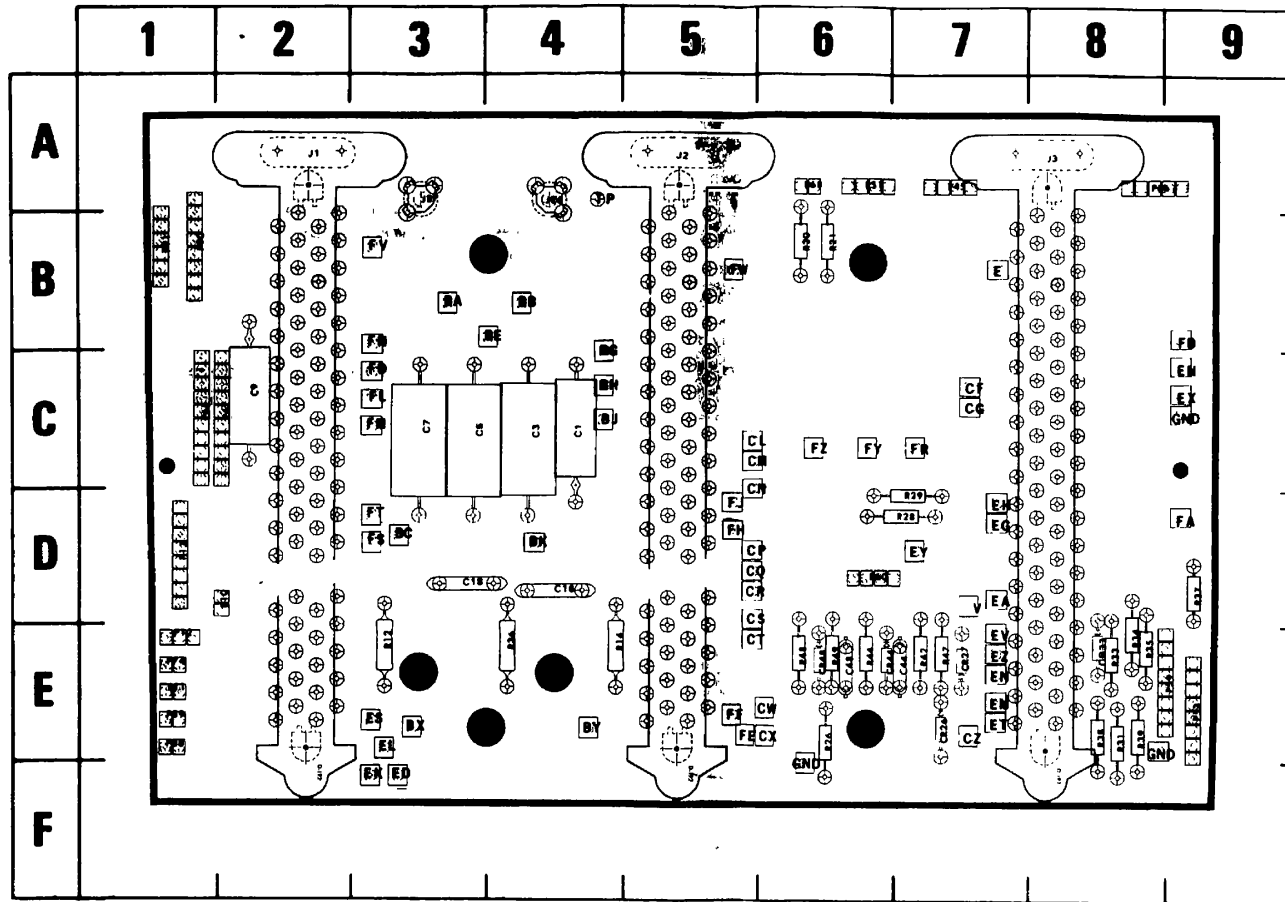

Figure 8-2. A1-Main Interface board.

CKT NO	GRID LOC	CKT NO	GRID LOC	CKT NO	GRID LOC	CKT NO	GRID LOC	CKT NO	GRID LOC
C1	4C	CR33	8E	P12	1E	P68	6A	R31	8E
C3	4C	CR44	6E	P13	1D	P74	1E	R33	8E
C5	3C	CR48	6E	P38	1E	P90	1B	R34	8E
C7	3C			P39	1E	P91	1B	R35	8E
C9	2C	J1	2A	P45	7A			R36	4E
C16	4D	J2	5A	P51	6A	R12	3E	R37	9D
C18	3D	J3	8A	P53	9E	R14	4E	R38	8E
C44	7E	J26	4A	P59	9E	R20	6B	R39	8E
C48	6E	J27	3A	P60	6D	R21	6B	R42	7E
				P65	1C	R26	6E	R44	6E
CR26	7E	P10	2D	P66	8A	R28	7D	R47	7E
CR27	7E	P11	1E	P67	2C	R29	7D	R48	6E
								R49	6E

MORE

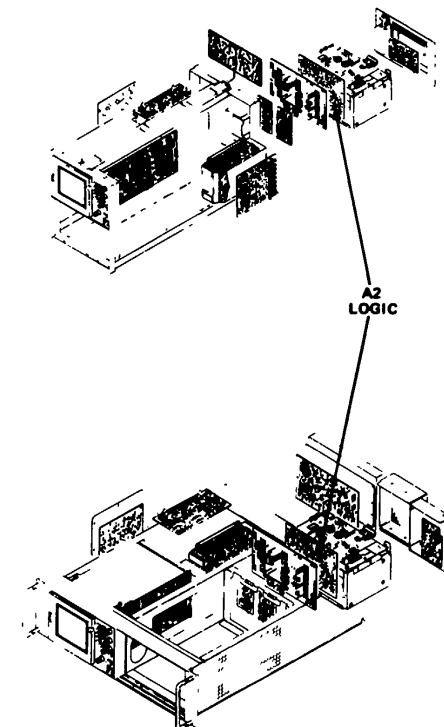
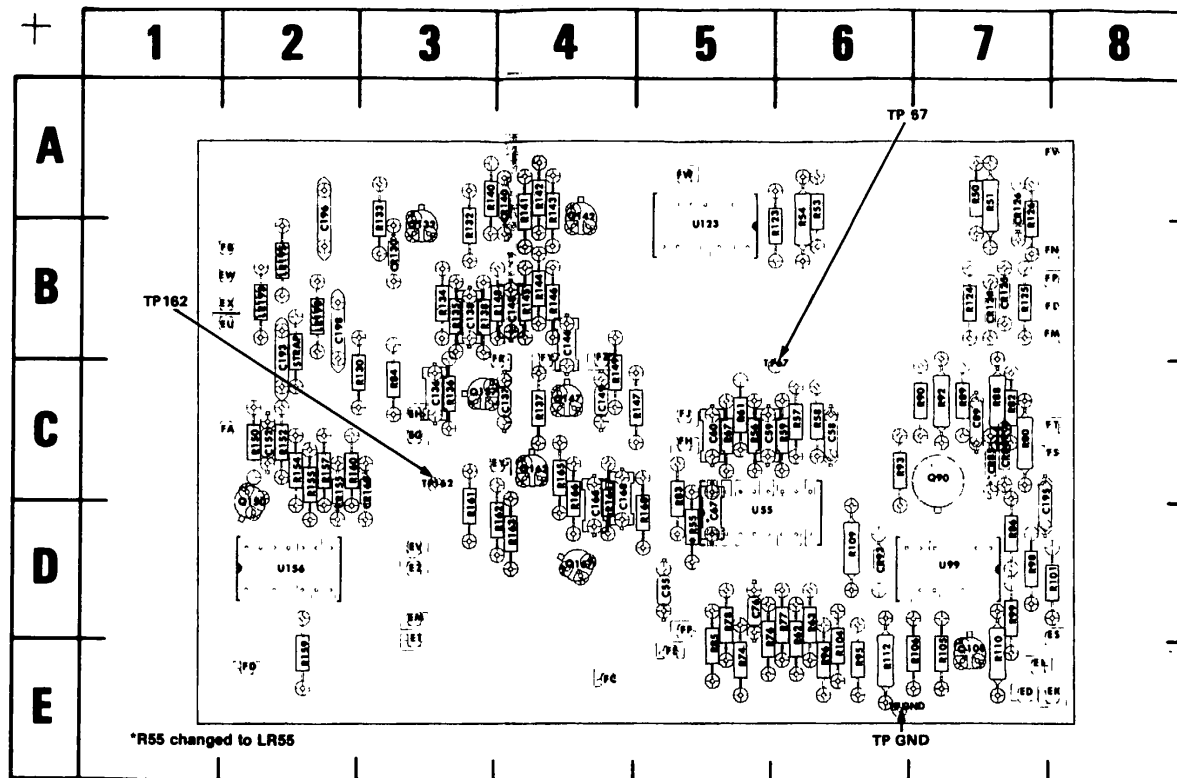

Figure 8-3. A2-Logic board.

CKT NO	GRID LOC	CKT NO	GRID LOC	CKT NO	GRID LOC	CKT NO	GRID LOC	CKT NO	GRID LOC	CKT NO	GRID LOC
C56	5D	CR85	7C	Q167	4D	R83	5C	R124	7B	R150	2C
C58	6C	CR93	6D	R80	7A	R84	3C	R125	7B	R152	2C
C59	5C	CR124	7B	R81	7A	R85	5E	R126	7A	R154	2C
C60	5C	CR125	7B	R82	7A	R86	7D	R130	3C	R155	2C
C67	5D	CR126	7A	R83	6A	R88	7C	R132	3B	R157	2C
C76	5D	CR130	3B	R84	6A	R89	7C	R133	3A	R159	2E
C89	7C	CR140	4A	R85	5D	R90	7C	R134	3B	R160	2C
C136	3C	CR155	2C	R86	5C	R92	7C	R135	3B	R161	3C
C137	4C	CR160	3C	R87	6C	R93	6C	R136	3C	R162	4D
C138	3B			R88	6C	R95	6E	R137	4C	R163	4D
C146	4B	LR193	2B	R89	6C	R96	6E	R138	3B	R164	4C
C148	4B	LR195	2B	R90	5C	R98	7D	R140	3A	R165	4C
C149	4C	LR198	2B	R92	6D	R99	7D	R145	4B	R166	4C
C152	2C	Q80	7C	R93	6D	R101	8D	R141	4A	R168	5D
C166	4C	Q108	7E	R97	5C	R104	6E	R142	4A	TP67	6C
C168	4C	Q132	3B	R74	5E	R105	7E	R143	4A	TP162	3C
C193	2B	Q137	3C	R76	5D	R106	7E	R144	4B		
C195	7C	Q142	4A	R77	6D	R109	6D	R146	4B	U55	5D
C196	2A	Q147	4C	R78	5D	R110	7E	R147	5C	U99	7D
C198	2B	Q150	2D	R80	7C	R112	6E	R148	4B	U123	5B
CR84	7C	Q162	4C	R82	7C	R123	6B	R149	4C	U156	2D

REV B, AUG 74

MORE

VOLTAGES AND WAVEFORMS

The voltages and waveforms shown on this diagram were obtained using the recommended test equipment and test set-ups listed below.

ITEM	RECOMMENDED TEST EQUIPMENT	
	SPECIFICATIONS	RECOMMENDED TYPE
Oscilloscope	Frequency response Deflection factor Input impedance Sweep rate	DC to 65 MHz 5 mV to 5 V/Div 10 MΩ, 20 pF 500 ns
Probe	Fast rise 10X attenuation probe compatible with the vertical amplifier of the test oscilloscope.	Tektronix P6053B, or equivalent.
Voltmeter (Non-Loading Digital Multimeter)	Input impedance Range	10 MΩ 0 to 500 V

VOLTAGE MEASUREMENTS

Voltage measurements on this diagram were made under the following conditions:
 Set front panel controls (knob type) to mid-range.
 Set VERT MODE for CHOP.
 Set TRIG SOURCE for VERT MODE.
 Set for NON STORE condition.
 No plug-in units are installed.
 Voltmeter common is connected to chassis ground.

WAVEFORMS

Waveforms shown on this diagram were obtained under the following conditions:
7623A OSCILLOSCOPE UNDER TEST. Front panel controls are set the same as for voltage measurements. A 7A15A Amplifier unit and a 7B53A Time-Base unit are installed in the mainframe under test. The test oscilloscope 4 Volts calibrator signal is applied to the amplifier unit. The amplifier unit is set for 1 V/division deflection centered on the crt. The 7B53A is set for internal auto-trigger, 0.5 ms/division sweep rate.
TEST OSCILLOSCOPE. The test oscilloscope is externally triggered from the +GATE OUT (MAIN) of the 7623A mainframe under test. The test oscilloscope is dc coupled.

Tolerances of voltages and waveforms shown are 20%.

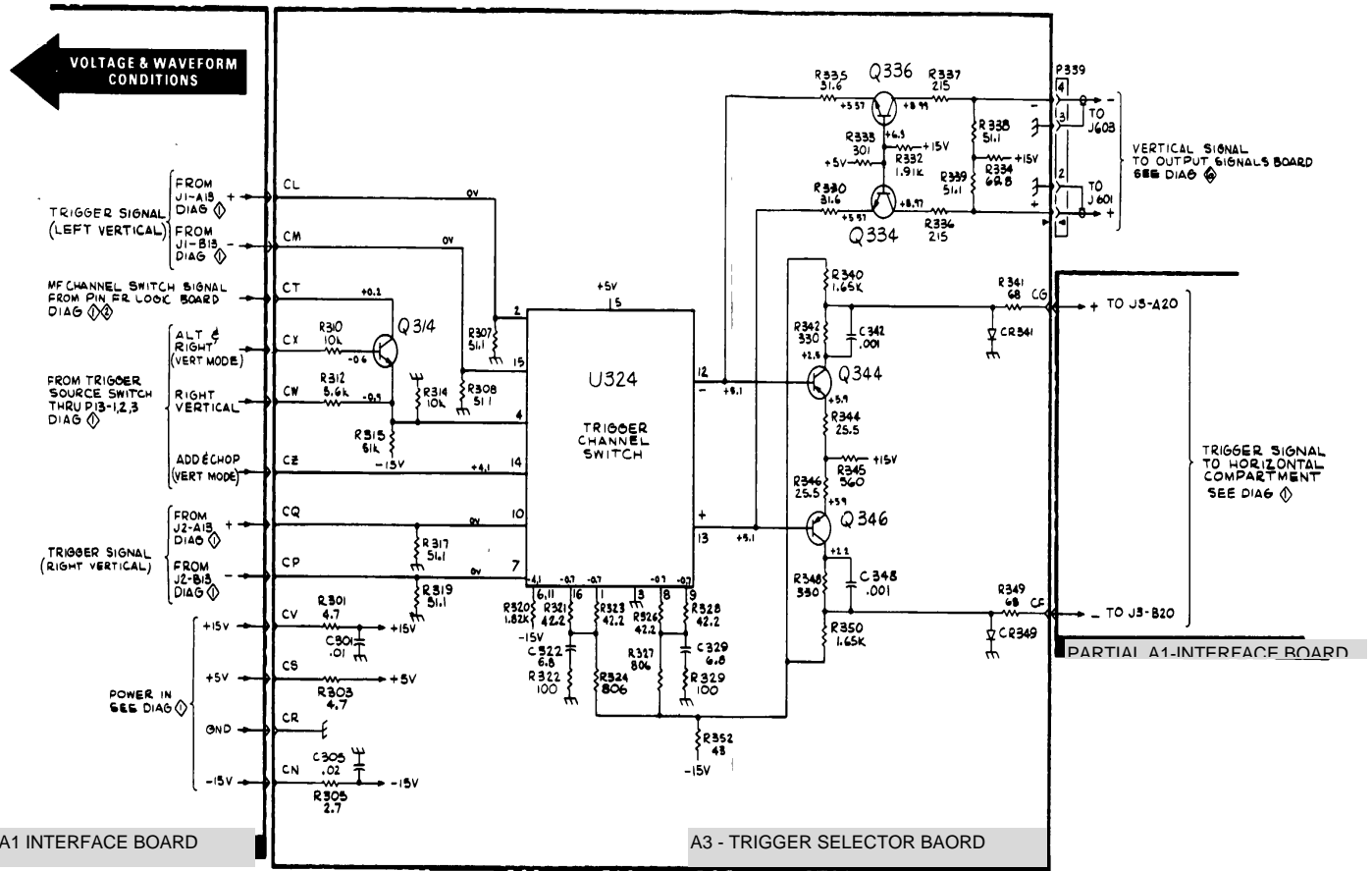

SEE PARTS LIST FOR SEMICONDUCTOR TYPES

7623A

TRIGGER SELECTOR ③
975 W-2

⊕
Figure 8-4. A3 Trigger Selector Board.

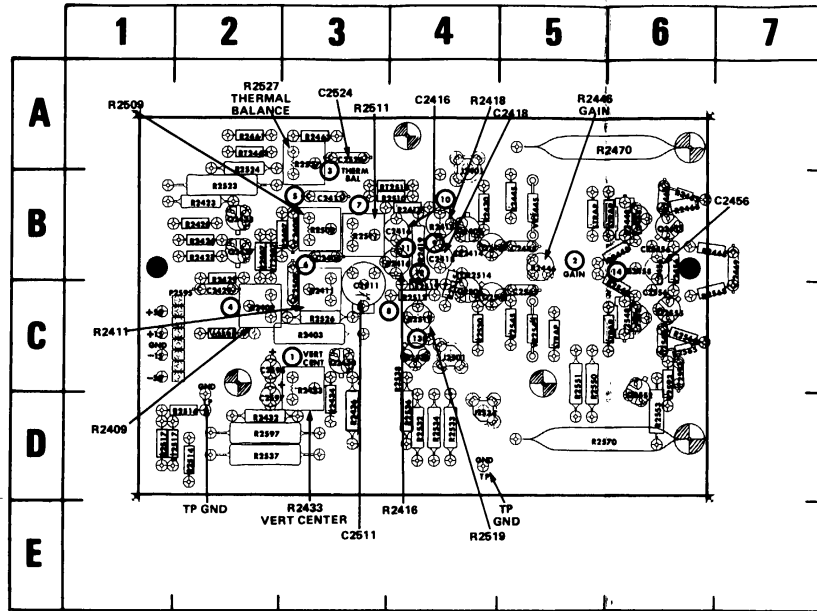

Figure 8-6. A5-Vertical Amplifier board (front).

CKT NO	GRID LOC	CKT NO	GRID LOC	CKT NO	GRID LOC	CKT NO	GRID LOC	CKT NO	GRID LOC	CKT NO	GRID LOC
C2403	3B	CR2414	4B	Q2455	8B	R2432	2D	R2512	4C	R2551	5C
C2409	3B	CR2456	8B	Q2505	4C	R2433	3C	R2514	2D	R2553	8D
C2411	3B	CR2514	4B	Q2530	4C	R2434	3D	R2515	4C	R2555	6C
C2416	4B			Q2541	4C	R2436	3D	R2516	2D	R2556	5B
C2418	4B	J2401	4A	Q2552	6D			R2517	1D	R2557	7C
C2429	2C	J2501	4C	Q2555	6C			R2519	4C	R2558	5D
C2445	5B	J2534	4D			R2445	5B	R2523	2B	R2559	6C
C2456	8B			R2403	3C	R2446	5B	R2524	2A	R2560	2D
C2465	8B	L2448	6B	R2407	3B	R2448	6B	R2526	3C		
C2469	7B	L2519	4C	R2409	2C	R2456	6B	R2527	3A	RT2463	2A
C2509	3C	L2548	6C	R2411	3C	R2458	6B	R2530	4C	RT2507	2B
C2511	3C	L2595	2C	R2412	4B	R2461	2A	R2532	4D	RT2510	4B
C2524	3A			R2416	4B	R2463	3A	R2533	4D	RT2517	2D
C2545	5C	P2595	2C	R2418	4B	R2465	6B	R2534	4D		
C2548	6C			R2419	4B	R2466	6B	R2536	4D	VR2445	5B
C2566	6C	Q2405	4B	R2423	2B	R2468	7B	R2537	2D	VR2545	5C
C2593	6C	Q2423	2B	R2425	2B	R2470	6A				
C2595	2C	Q2427	2B	R2426	2B	R2507	2B				
C2597	2D	Q2430	3C	R2427	2B	R2509	3B	R2545	5C		
C2665	6C	Q2441	4B	R2429	2B	R2510	4B	R2548	6C		
				R2430	4B	R2511	3B	R2550	5C		

MORE

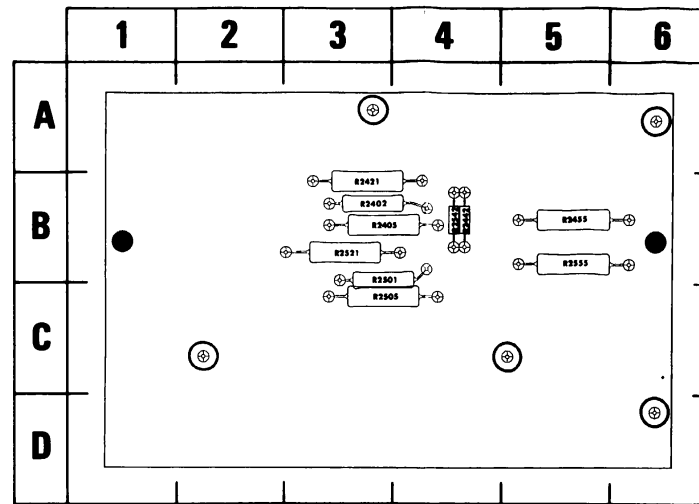
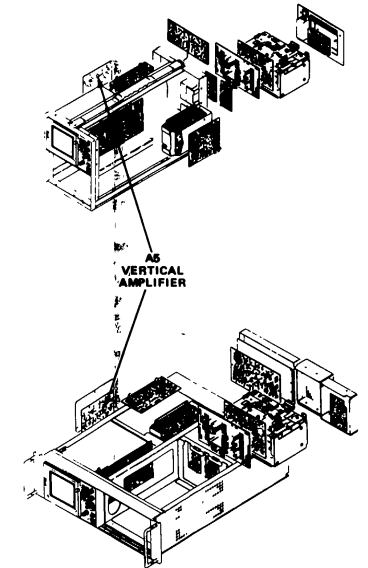

Figure 8-7. A5-Vertical Amplifier board (rear).

CKT NO	GRID LOC
R2402	3B
R2405	3B
R2421	3B
R2442	4B
R2455	5B
R2501	3C
R2505	3B
R2521	3B
R2542	4B
R2555	5B



VOLTAGES AND WAVEFORMS

The voltages and waveforms shown on this diagram were obtained using the recommended test equipment and test set-ups listed below

ITEM	RECOMMENDED TEST EQUIPMENT SPECIFICATIONS		RECOMMENDED TYPE
	Frequency response	DC to 65 MHz	
Oscilloscope	Deflection factor	5 mV to 5 V/Div	Tektronix 7603 or 7613 equipped with 7A15A Amplifier and 7B53A Time-Base unit, or equivalent. A 7A13 Differential Comparator was used to obtain offset
	Input impedance	10 MΩ, 20 pF	
	Sweep rate	500 ns	
Probe	Fast rise 10X attenuation probe compatible with the vertical amplifier of the test oscilloscope.		Tektronix P6053B, or equivalent
	Input impedance	10 MΩ	
Voltmeter (Non-Loading Digital Multimeter)	Range	0 to 500 V	Tektronix 7D13 Digital Multimeter (test oscilloscope must have readout system) or Tektronix DM 501 Digital Multimeter with power module, or equivalent
	Range	0 to 500 V	

VOLTAGE MEASUREMENTS

Voltage measurements on this diagram were made under the following conditions:
 Set front panel controls (knob type) to mid-range.
 Set VERT MODE for CHOP.
 Set TRIG SOURCE for VERT MODE.
 Set for NON STORE condition.
 No plug-in units are installed.
 Voltmeter common is connected to chassis ground.

WAVEFORMS

Waveforms shown on this diagram were obtained under the following conditions:

7623A OSCILLOSCOPE UNDER TEST Front panel controls are set the same as for voltage measurements. A 7A15A Amplifier unit and a 7B53A Time-Base unit are installed in the mainframe under test. The test oscilloscope 4 Volts calibrator signal is applied to the amplifier unit. The amplifier unit is set for 1 V/division deflection centered on the crt. The 7B53A is set for internal auto-trigger, 0.5 ms/division sweep rate.

TEST OSCILLOSCOPE. The test oscilloscope is externally triggered from the +GATE OUT (MAIN) of the 7623A mainframe under test. The test oscilloscope is dc coupled.

Tolerances of voltages and waveforms shown are 20%.

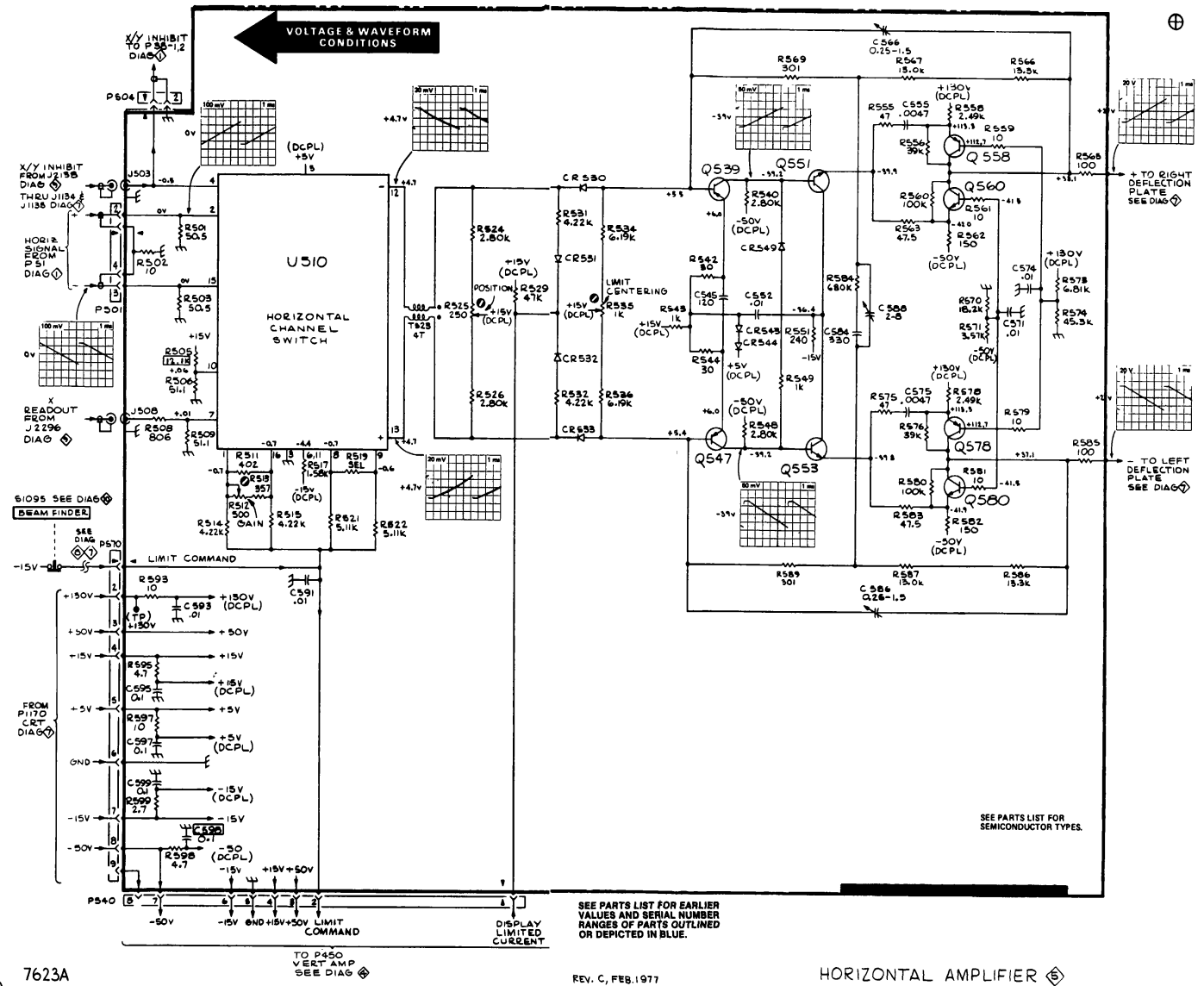

7623A

SEE PARTS LIST FOR EARLIER VALUES AND SERIAL NUMBER RANGES OF PARTS OUTLINED OR DEPICTED IN BLUE.

REV. C, FEB. 1977

HORIZONTAL AMPLIFIER

Figure 8-8. A6-Horizontal Amplifier Board.

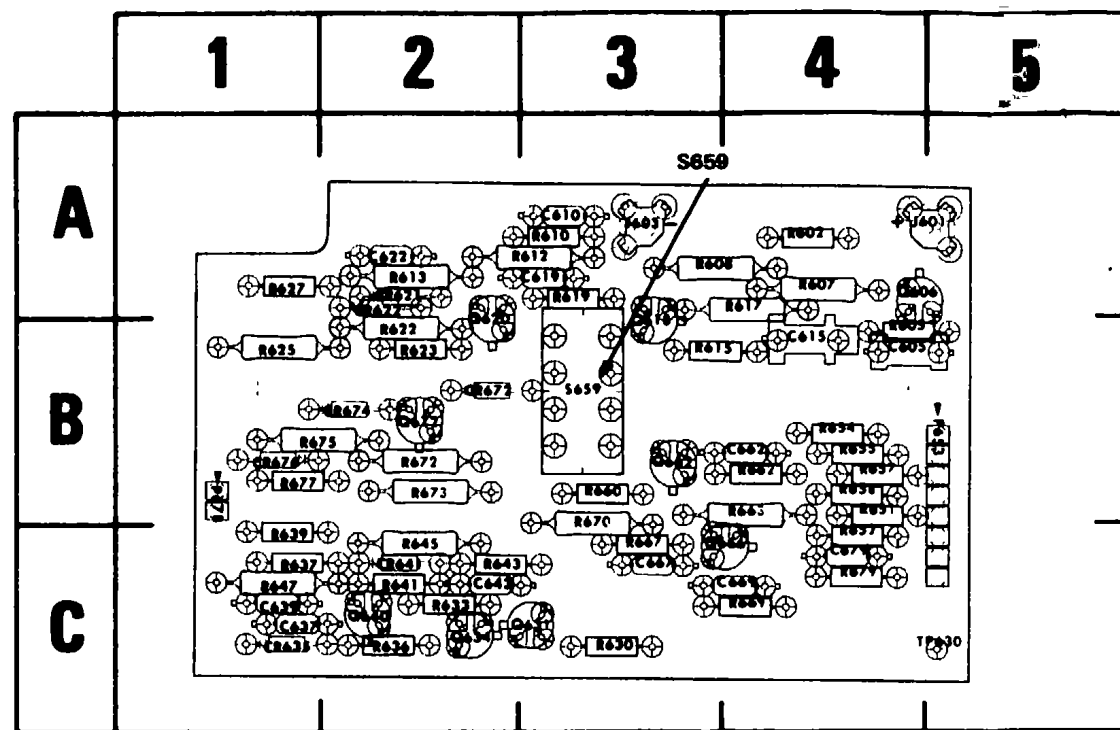
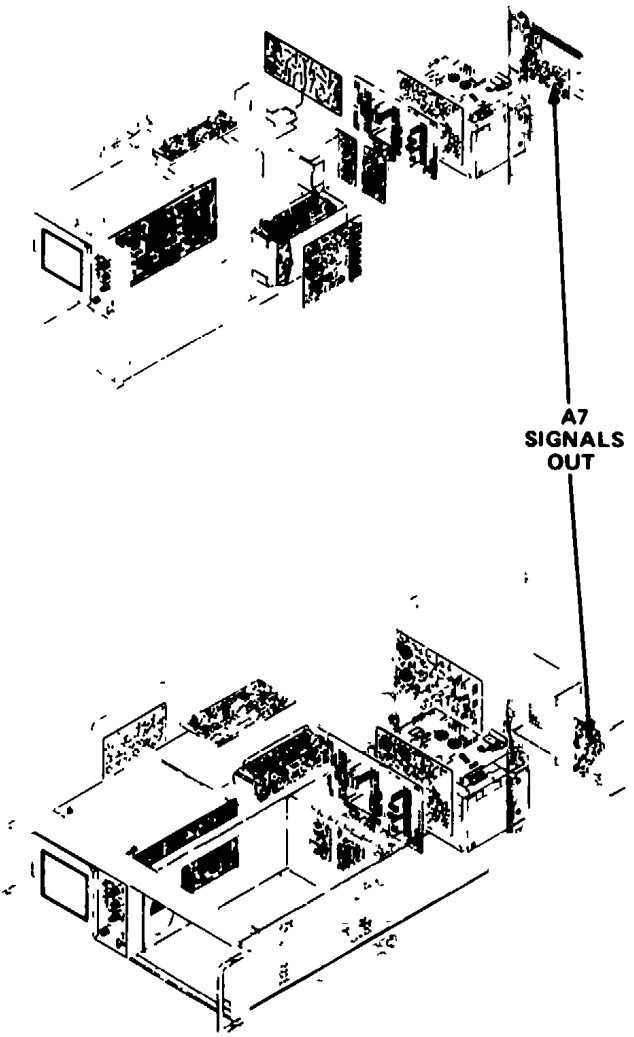

Figure 8-9. A7-Output Signals board.

CKT NO	GRID LOC	CKT NO	GRID LOC	CKT NO	GRID LOC	CKT NO	GRID LOC
C805	4B	J603	3A	R615	3B	R660	3B
C810	3A			R617	4A	R662	4B
C815	4B	P653	5B	R619	3A	R663	4B
C819	3A	P678	1B	R622	2B	R667	3C
C822	2A			R623	2B	R669	4C
C837	1C	Q606	4A	R625	1B	R670	3B
C839	1C	Q618	3B	R627	1A	R672	2B
C643	2C	Q620	2A	R630	3C	R673	2B
C662	4B	Q631	3C	R633	2C	R675	2B
C667	3C	Q634	2C	R636	2C	R677	1B
C669	4C	Q640	2C	R637	1C	R679	4C
C679	4C	Q662	3B	R639	1C		
		Q666	4C	R641	2C	S659	3B
CR621	2A	Q672	2B	R643	2C		
CR622	2A			R645	2C	TP630	5C
CR636	1C	R602	4A	R647	1C		
CR641	2C	R605	4B	R651	4B		
CR672	2B	R607	4A	R652	4C		
CR674	2B	R608	3A	R654	4B		
CR676	1B	R610	3A	R655	4B		
		R612	3A	R657	4B		
J601	5A	R613	2A	R658	4B		

(A)

MORE



VOLTAGES AND WAVEFORMS

The voltages and waveforms shown on this diagram were obtained using the recommended test equipment and test set-ups listed below

ITEM	SPECIFICATIONS	RECOMMENDED TYPE
Oscilloscope	Frequency response DC to 85 MHz Deflection factor 5 mV to 5 V/Div Input impedance 10 MΩ, 20 pF Sweep rate 500 ns	Tektronix 7603 or 7613 equipped with 7A15A Amplifier and 7B53A Time-Base unit, or equivalent. A 7A13 Differential Comparator was used to obtain offset.
Probe	Fast rise 10X attenuation probe compatible with the vertical amplifier of the test oscilloscope.	Tektronix P6053B, or equivalent
Voltmeter (Non-Loading Digital Multimeter)	Input impedance 10 MΩ Range 0 to 500 V	Tektronix 7D13 Digital Multimeter (test oscilloscope must have readout system) or Tektronix DM 501 Digital Multimeter with power module, or equivalent

VOLTAGE MEASUREMENTS

Voltage measurements on this diagram were made under the following conditions
 Set front panel controls (knob type) to mid-range
 Set VERT MODE for CHOP.
 Set TRIG SOURCE for VERT MODE.
 Set for NON STORE condition.
 No plug-in units are installed.
 Voltmeter common is connected to chassis ground.

WAVEFORMS

Waveforms shown on this diagram were obtained under the following conditions.

7823A OSCILLOSCOPE UNDER TEST. Front panel controls are set the same as for voltage measurements. A 7A15A Amplifier unit and a 7B53A Time-Base unit are installed in the mainframe under test. The test oscilloscope 4 Volts calibrator signal is applied to the amplifier unit. The amplifier unit is set for 1 V/division deflection centered on the crt. The 7B53A is set for internal auto-trigger, 0.5 ms/division sweep rate.

TEST OSCILLOSCOPE. The test oscilloscope is externally triggered from the +GATE OUT (MAIN) of the 7823A mainframe under test. The test oscilloscope is dc coupled.

Tolerances of voltages and waveforms shown are 20%.

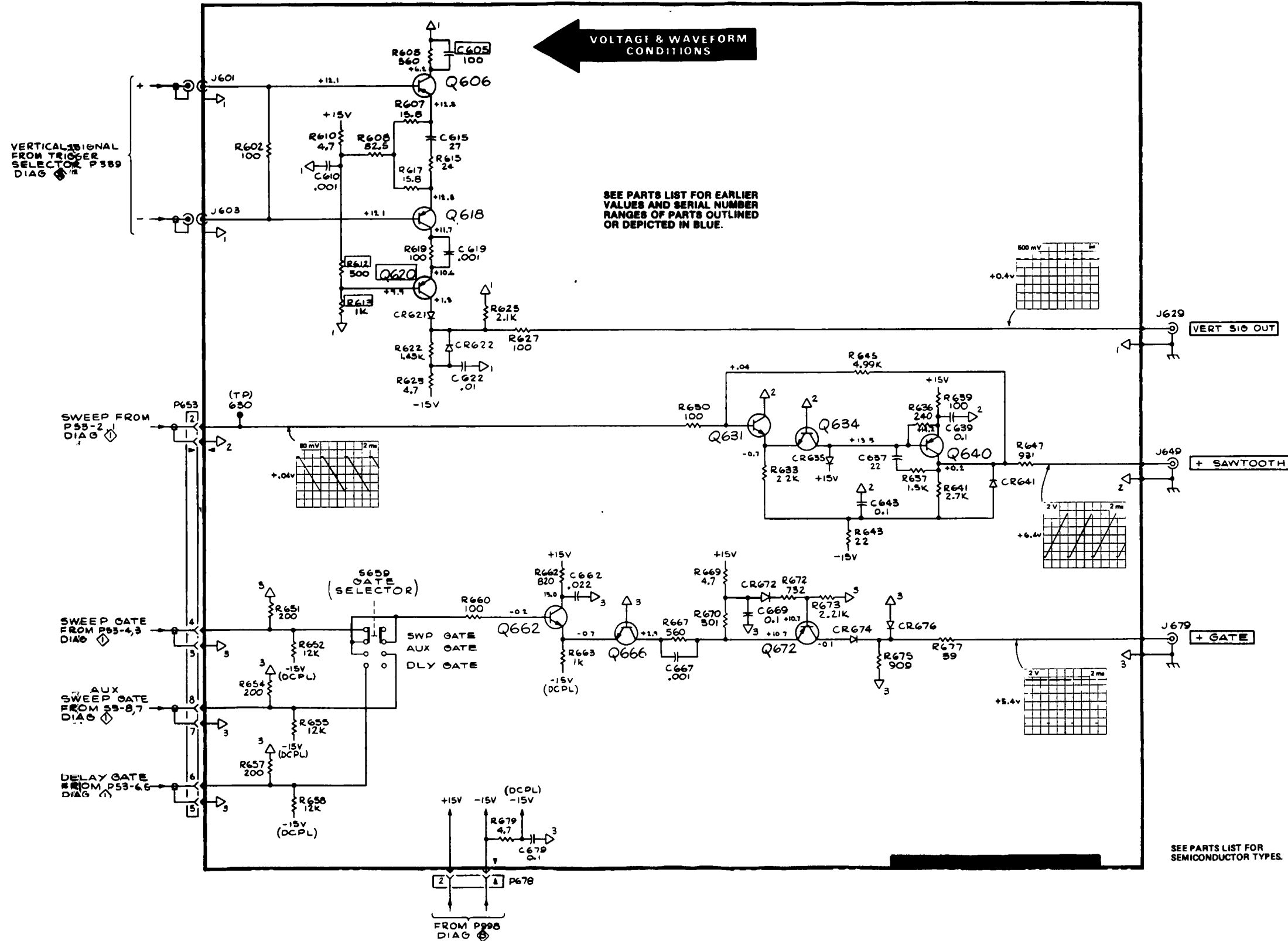

VOLTAGE & WAVEFORM CONDITIONS

SEE PARTS LIST FOR EARLIER VALUES AND SERIAL NUMBER RANGES OF PARTS OUTLINED OR DEPICTED IN BLUE.

SEE PARTS LIST FOR SEMICONDUCTOR TYPES.

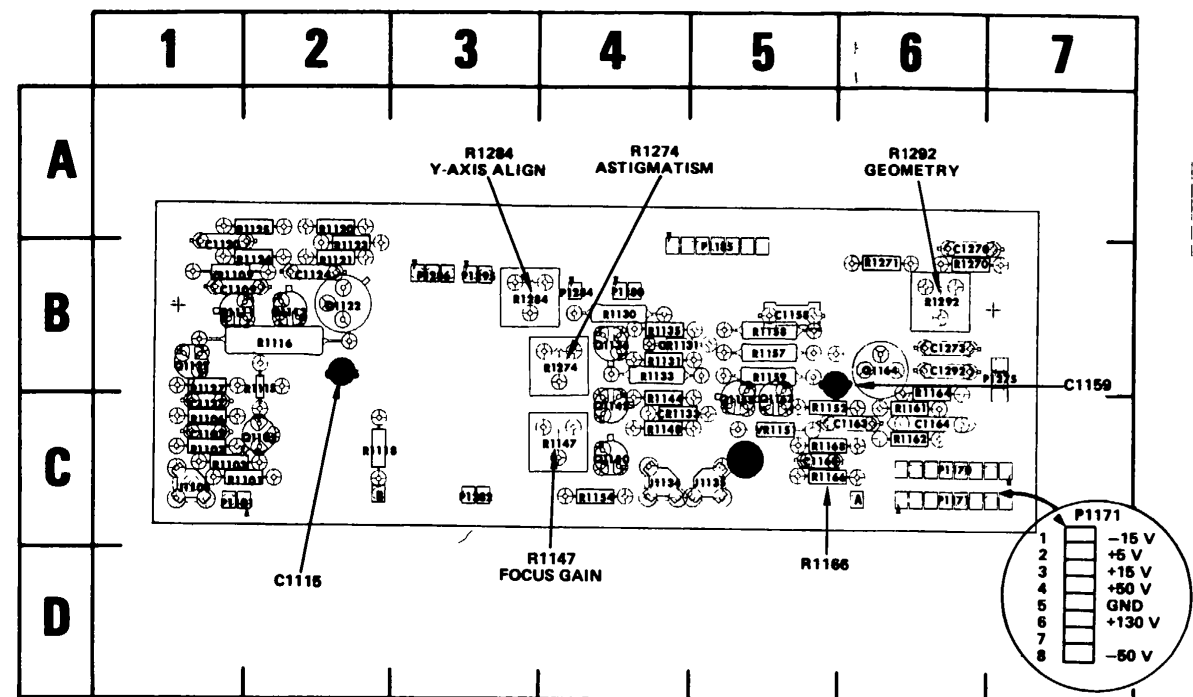
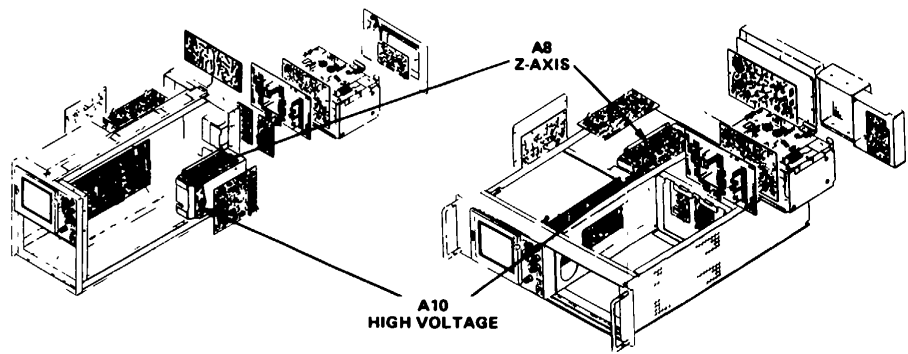

Figure 8-10. A8-Z-Axis board.

CKT NO	GRID LOC	CKT NO	GRID LOC	CKT NO	GRID LOC	CKT NO	GRID LOC
C1107	1C	P1180	4B	R1116	2B	R1270	6B
C1109	1B	P1185	5B	R1118	2C	R1271	6B
C1115	2B	P1265	3B	R1120	2A	R1274	4B
C1120	1B	P1275	7B	R1121	2B	R1284	3B
C1124	2B	P1282	3C	R1123	2B	R1292	6B
C1127	1C	P1284	4B	R1124	2A		
C1158	5B	P1286	3B	R1125	2A	VR1109	1B
C1159	5B			R1127	1B	VR1151	5C
C1163	6C	Q1105	2C	R1131	4B		
C1164	6C	Q1111	1B	R1133	4B		
C1168	5C	Q1113	2B	R1136	4B		
C1270	6B	Q1122	2B	R1144	4C		
C1273	6B	Q1127	1B	R1147	4C		
C1292	6B	Q1136	4B	R1148	4C		
		Q1145	4C	R1152	5C		
CR1131	4B	Q1150	4C	R1154	4C		
CR1133	4C	Q1155	5C	R1157	5B		
		Q1164	6B	R1158	5B		
J1103	1C	Q1167	5C	R1159	5B		
J1134	4C			R1161	6C		
J1135	5C	R1101	1C	R1162	6C		
		R1103	1C	R1164	6B		
P1101	1C	R1106	1C	R1166	5C		
P1170	6C	R1107	1C	R1168	5C		
P1171	6C	R1115	2B	R1180	4B		

MORE



CKT NO	GRID LOC
C1201	D2
C1202	2B
C1206	B3
CR1202	4D
CR1203	3C
R1204	4C
R1205	4B
R1206	4B
R1207	4B
R1208	3A

Located on front of board:
 C1201
 C1202 (relocated from back of board SN B050000-up)
 C1206 (relocated to back of board SN B050000-up)

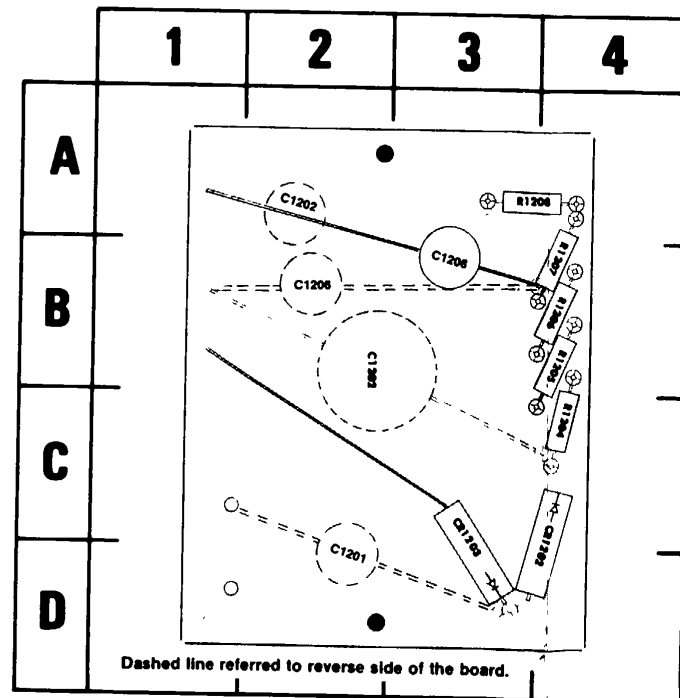

Figure 8-11. A9-Anode board (back view).

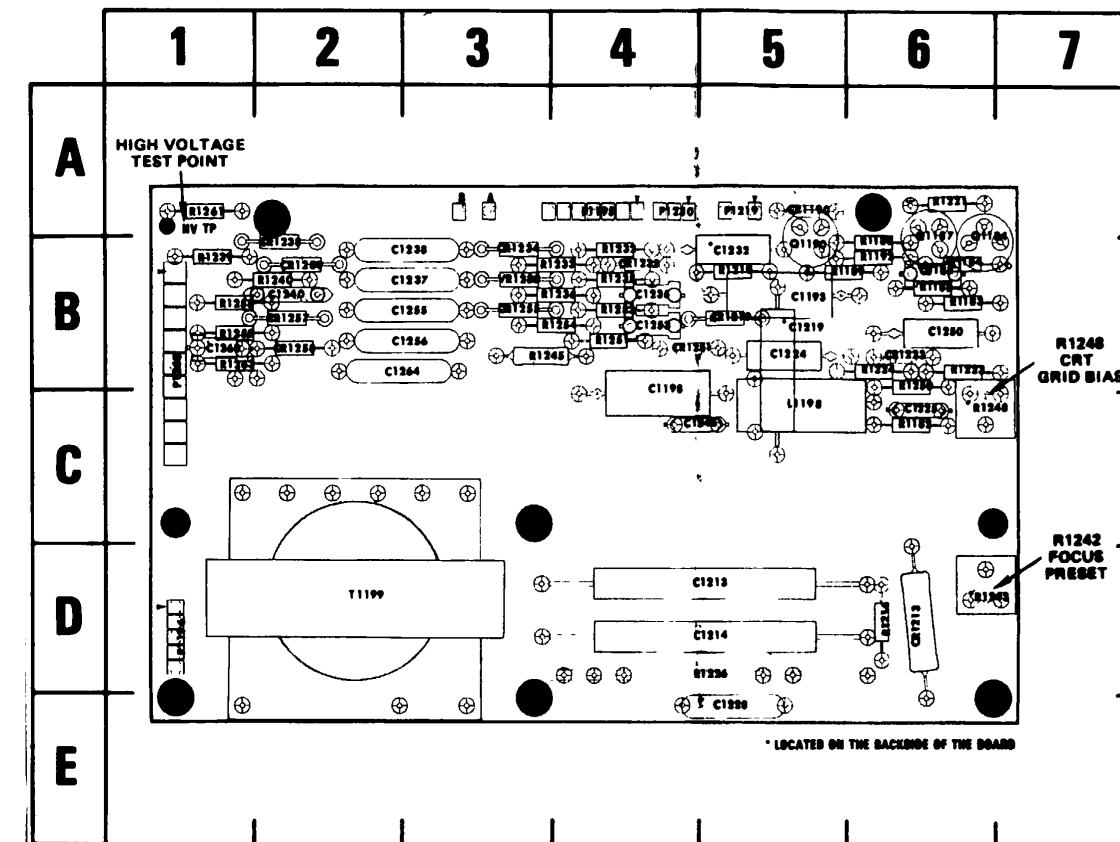

Figure 8-12. A10-High Voltage board.

CKT NO	GRID LOC	CKT NO	GRID LOC	CKT NO	GRID LOC	CKT NO	GRID LOC
C1185	6B	C1264	2B	P1230	4A	R1226	5D
C1193	5B			P1260	1B	R1232	4B
C1198	4B	CR1190	5A			R1233	4B
C1213	5D	CR1213	6D	Q1184	6A	R1235	4B
C1214	5D	CR1219	5B	Q1187	6A	R1236	4B
C1219	5B	CR1223	6B	Q1190	5B	R1239	1B
C1224	5B	CR1233	4B			R1240	2B
C1225	6C	CR1234	3B			R1242	6D
C1228	5E	CR1238	2B	R1182	6C	R1245	4B
C1232	5B	CR1239	2B	R1183	6B	R1248	6C
C1235	4B	CR1251	4B	R1184	6B	R1250	6B
C1237	3B	CR1255	3B	R1185	6B	R1251	4B
C1238	3B	CR1257	2B	R1188	6B	R1253	4B
C1240	2B	CR1258	2B	R1189	6B	R1254	4B
C1245	5C			R1192	6B	R1258	1B
C1250	6B	L1198	5C	R1214	6D	R1259	1B
C1253	4B			R1219	5B	R1271	1A
C1255	3B	P1195	4A	R1221	6A	R1263	1B
C1256	3B	P1196	1D	R1223	6B	T1199	2D
C1263	1B	P1219	5A	R1224	6B	VR1233	3B

7623A/R7623A Service

VOLTAGES AND WAVEFORMS

The voltages and waveforms shown on this diagram were obtained using the recommended test equipment and test set-ups listed below.

ITEM	RECOMMENDED TEST EQUIPMENT SPECIFICATIONS		RECOMMENDED TYPE
	Frequency response	DC to 15 MHz	
Oscilloscope	Deflection factor	5 mV to 5 V/Div	Tektronix 7603 or 7613 equipped with 7A15A Amplifier and 7B53A Time-Base unit, or equivalent. A 7A13 Differential Comparator was used to obtain offset.
	Input impedance	10 MΩ 20 pF	
	Sweep rate	500 ns	
Probe	Fast rise 10X attenuation probe compatible with the vertical amplifier of the test oscilloscope.		Tektronix P6053B, or equivalent.
	Input impedance	10 MΩ	
Voltmeter (Non-Loading Digital Multimeter)	Range	0 to 50 V	Tektronix 7D13 Digital Multimeter (test oscilloscope must have readout system) or Tektronix DM 501 Digital Multimeter with power module, or equivalent.

VOLTAGE MEASUREMENTS

Voltage measurements on this diagram were made under the following conditions:
 Set front panel controls (knob type) to mid-range.
 Set VERT MODE for CHOP.
 Set TRIG SOURCE for VERT (MODE).
 Set for NON STORE condition.
 No plug-in units are installed.
 Voltmeter common is connected to chassis ground.

WAVEFORMS

Waveforms shown on this diagram were obtained under the following conditions:
 7623A OSCILLOSCOPE UNDER TEST. Front panel controls are set the same as for voltage measurements. A 7A15A Amplifier unit and a 7B53A Time Base unit are installed in the mainframe under test. The test oscilloscope 4 Volts calibrator signal is applied to the amplifier unit. The amplifier unit is set for 1 V/division deflection centered on the crt. The 7B53A is set for internal auto-trigger, 0.5 ms/division sweep rate.

TEST OSCILLOSCOPE. The test oscilloscope is dc coupled and internally triggered.
 Tolerances of voltages and waveforms shown are 20%.

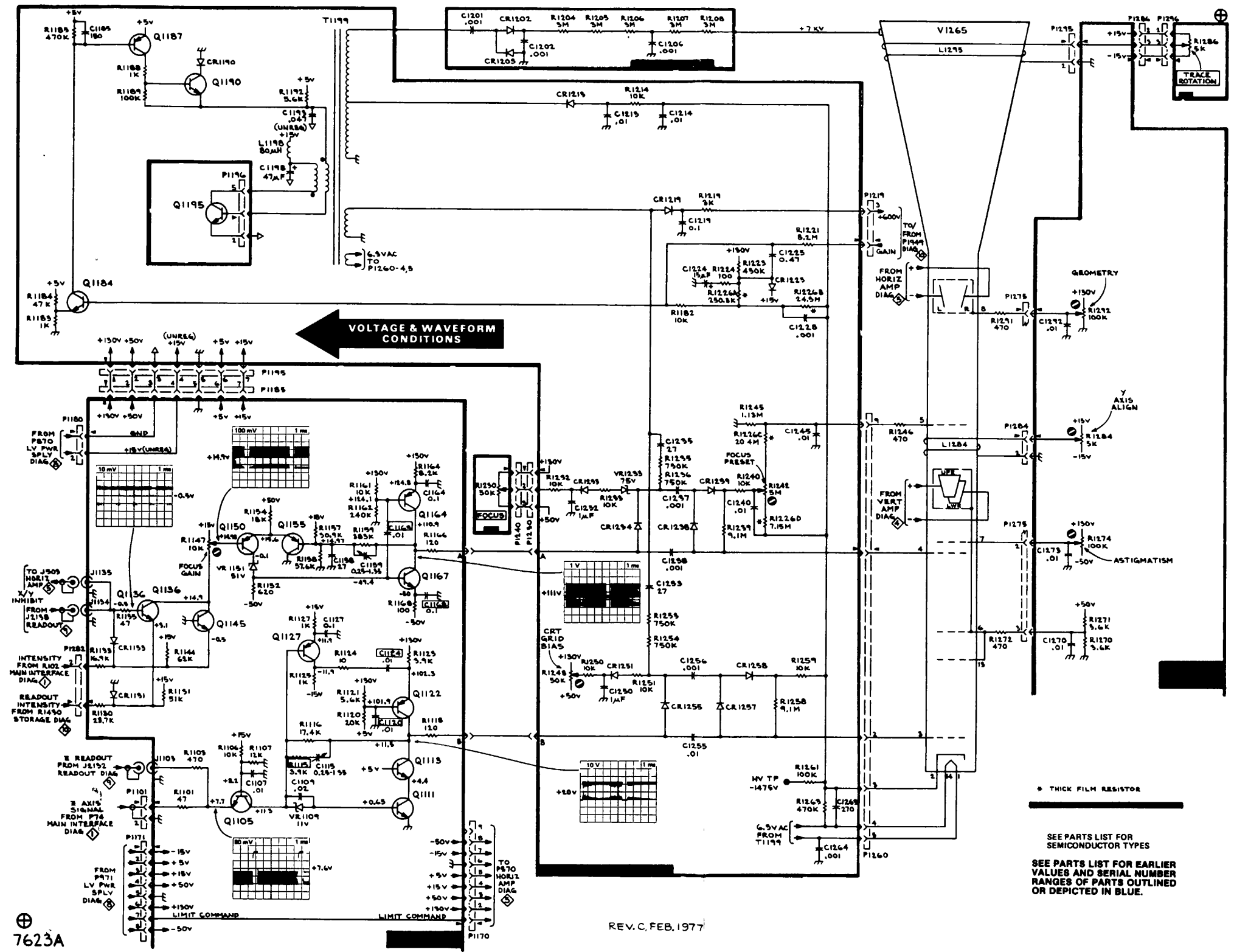

7623A

REV. C, FEB. 1977

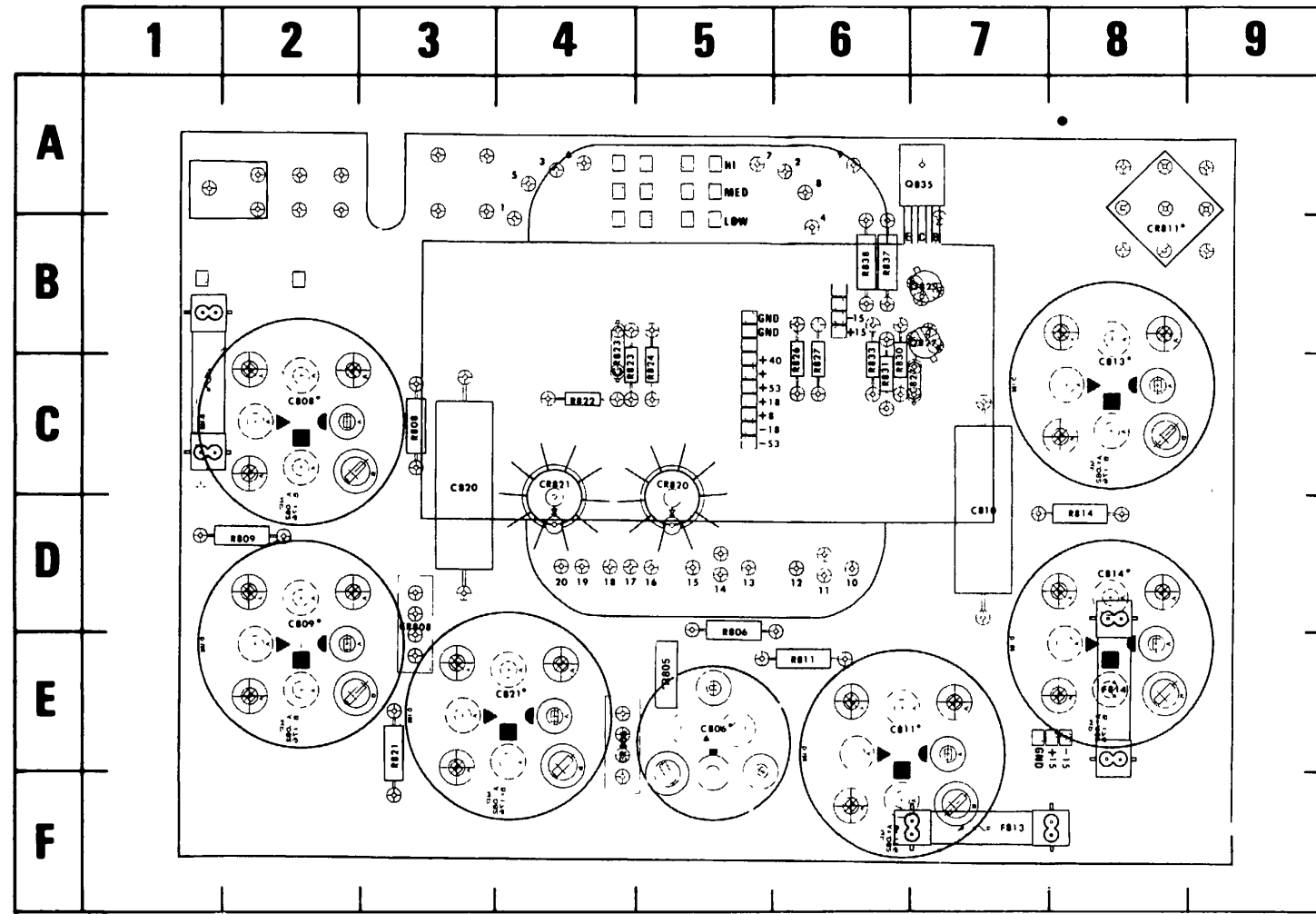

Figure 8-13. A11-Low Voltage Rectifier board.

REV B, AUG 74

*Located on backside of board
*See Parts List for serial number ranges

CKT NO	GRID LOC	CKT NO	GRID LOC	CKT NO	GRID LOC
C806	5E	CR811	8B	R808	3C
C808	2C	CR820	5C	R809	2D
C809	2D	CR821	4C	R811	6E
C810	7D	CR823	4C	R814	8D
C811	6E			R821	3E
C813	8C	F813	7F	R822	4C
C814	8D	F814	8E	R824	5C
C820	3D			R826	5C
C821	4E	Q825	7A	R827	6C
C827	7C	Q877	7B	R830	6C
		Q829	7B	R831	6C
CR806	4E	R805	5E	R833	6C
CR808	3D	R806	5D	R837	6B
				R838	6B

MORE

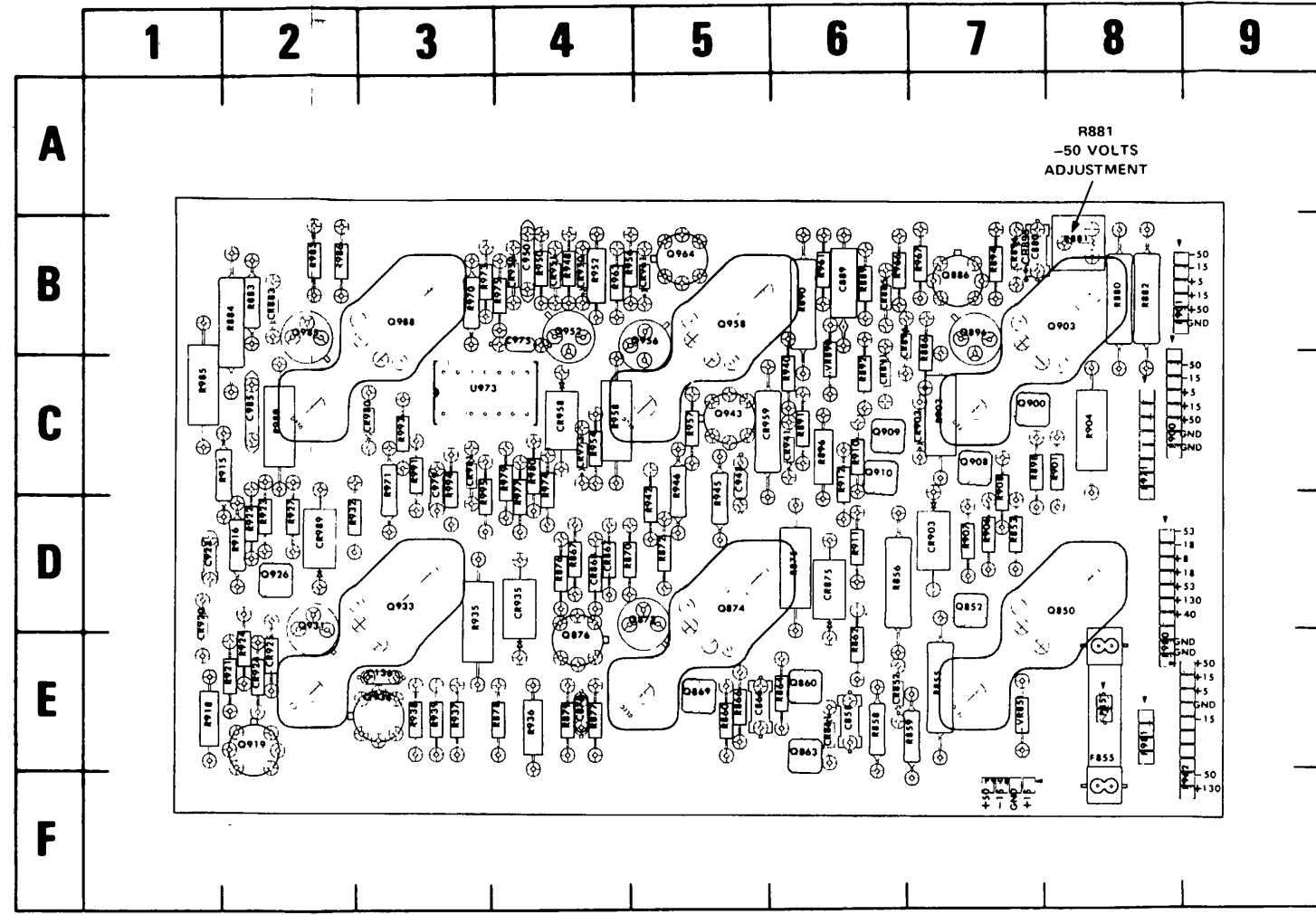
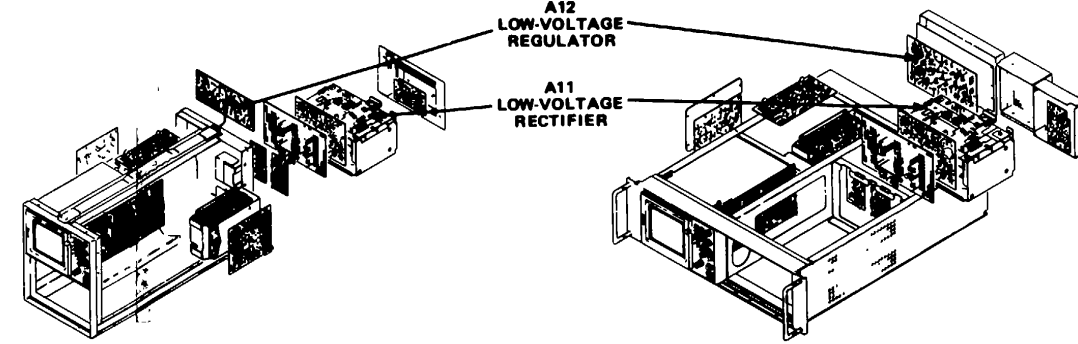

Figure 8-14. A12-Low-Voltage Regulator board.

REV B, JAN 1975



CKT NO	GRID LOC	CKT NO	GRID LOC	CKT NO	GRID LOC
C136	3E	Q874	5D	R907	7D
C858	6E	Q876	4E	R908	7C
C866	5E	Q886	7B	R910	6C
C876	4E	Q896	7B	R911	6D
C880	7B	Q900	7C	R912	6C
C889	6B	Q903	8B	R915	2C
C923	1D	Q908	7C	R916	2D
C943	5C	Q909	6C	R918	1E
C950	4B	Q910	6C	R921	2E
C975	4B	Q919	2E	R922	2D
C979	3C	Q926	2D	R923	2D
C985	2C	Q931	2D	R924	2E
		Q933	3D	R927	2D
CR852	6E	Q936	3E	R932	2D
CR861	6E	Q943	5C	R935	3D
CR867	4D	Q952	4B	R936	4E
CR868	4D	Q956	5B	R937	3E
CR875	6D	Q958	5B	R938	3E
CR883	2B	Q964	5B	R939	3E
CR885	6B	Q985	2B	R940	6C
CR891	6C	Q988	3B	R942	5D
CR894	7B			R945	5C
CR895	7B	R853	7D	R946	5C
CR896	6B	R855	7E	R948	4B
CR903	7D	R856	6D	R950	4B
CR920	1D	R858	6E	R952	4B
CR924	2E	R859	7E	R954	4C
CR925	2E	R860	5E	R956	4B
CR935	4D	R862	6E	R957	5C
CR941	6C	R864	6E	R958	4C
CR950	4B	R866	5E	R961	6B
CR951	4B	R867	4D	R963	4B
CR952	4B	R870	4D	R966	6B
CR958	4C	R872	5D	R967	7B
CR959	5C	R875	6D	R970	3B
CR961	5B	R876	4D	R971	3C
CR973	4C	R877	4E	R973	3B
CR980	3C	R878	4E	R974	4C
CR981	3C	R879	4E	R975	4B
CR989	2D	R880	8B	R977	4C
		R881	8B	R979	4C
F855	8E	R882	8B	R980	4C
		R883	2B	R983	2B
P855	8E	R884	2B	R985	1C
P900	8C	R886	7B	R986	2B
P901	8B	R889	6B	R989	2C
P971	8C	R890	6B	R991	3C
P980	8E	R891	6C	R993	3C
P981	8E	R892	6C	R994	3C
P998	7F	R894	7B	R995	3C
		R896	6C		
Q850	8D	R898	7C	U973	3C
Q852	7D	R901	8C		
Q860	6E	R903	7C	VR851	7E
Q863	6E	R904	8C	VR890	6C
Q869	5E	R906	7D		
Q872	5D				

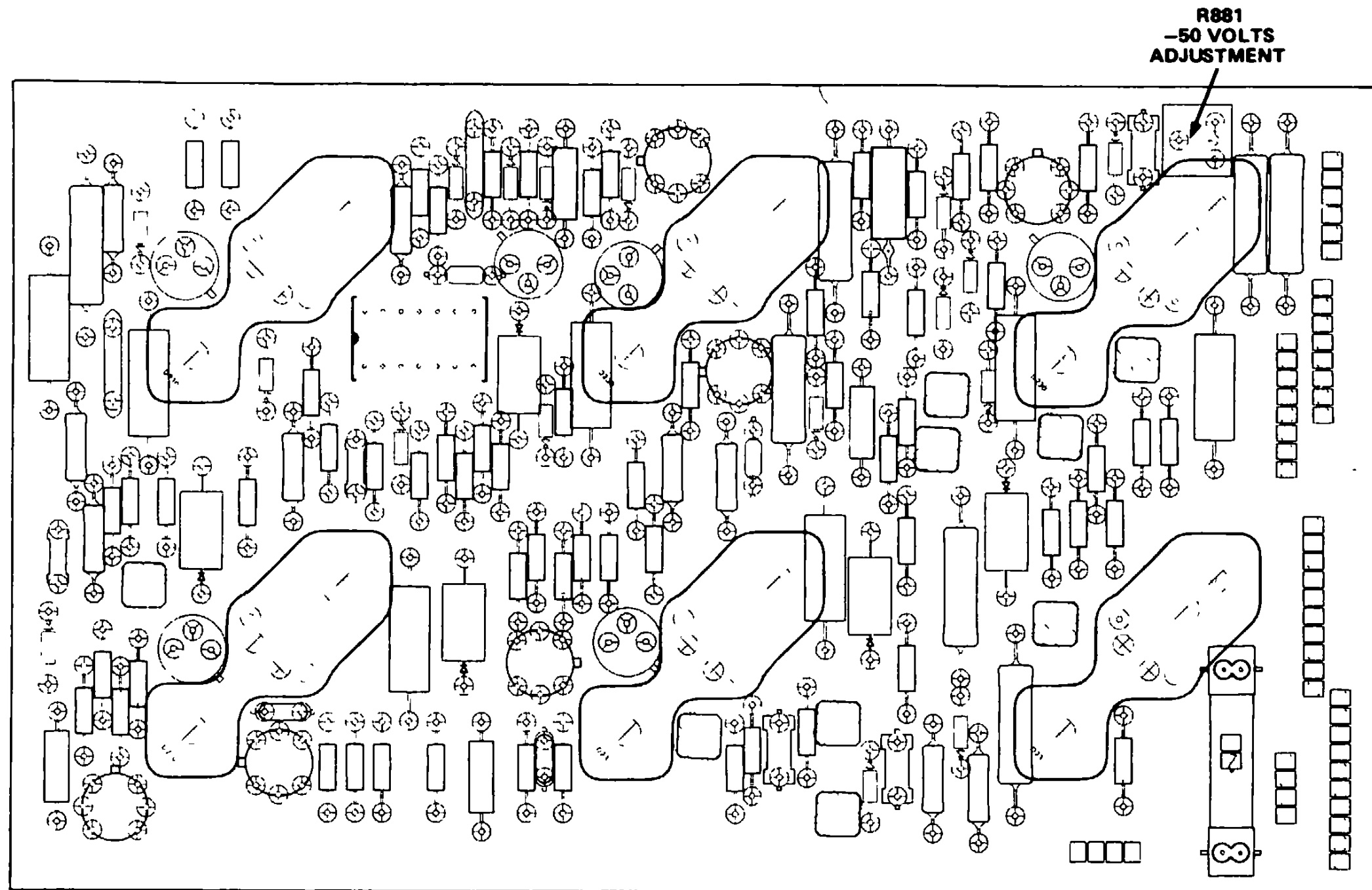
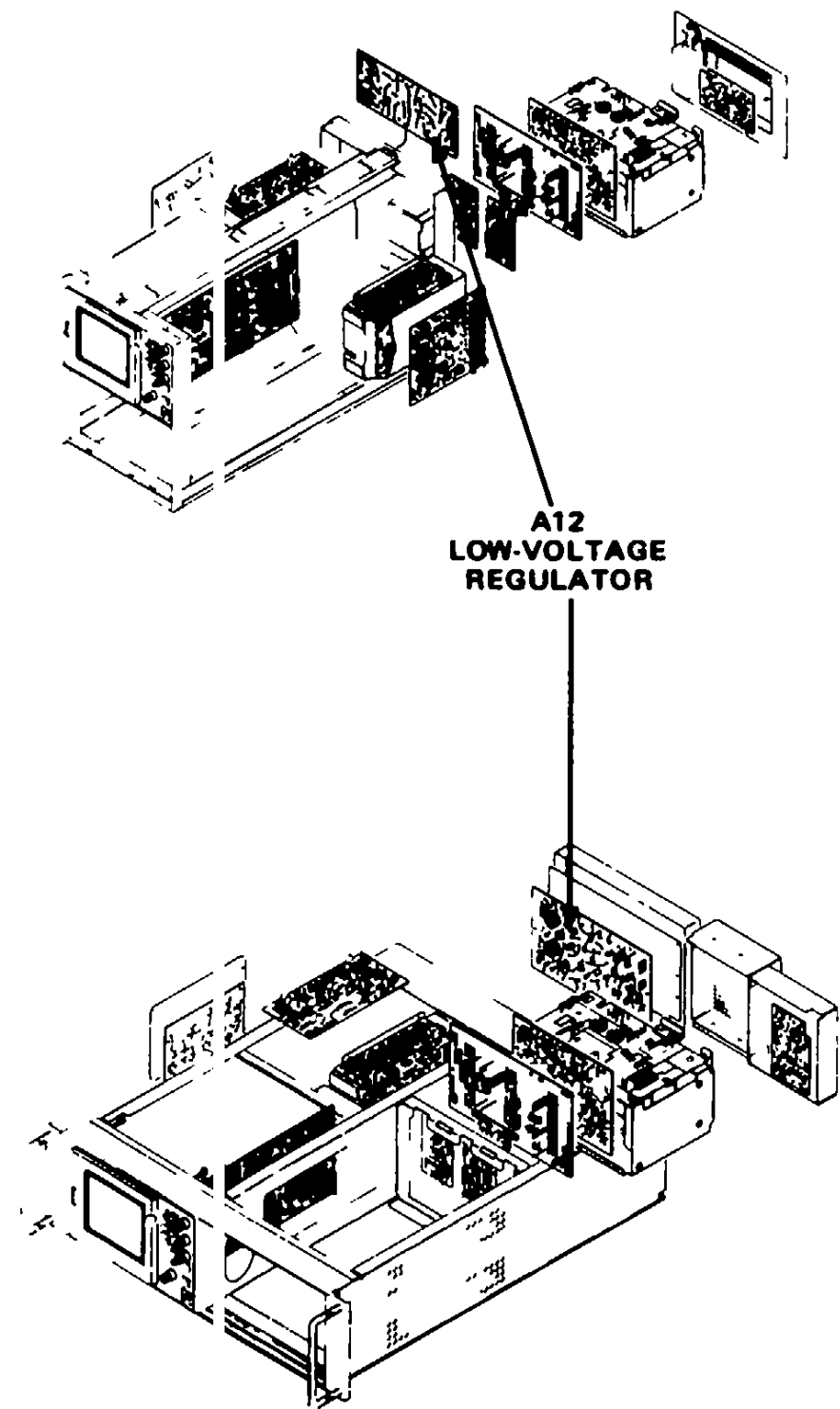

Figure 8-17. Low Voltage Regulator board.

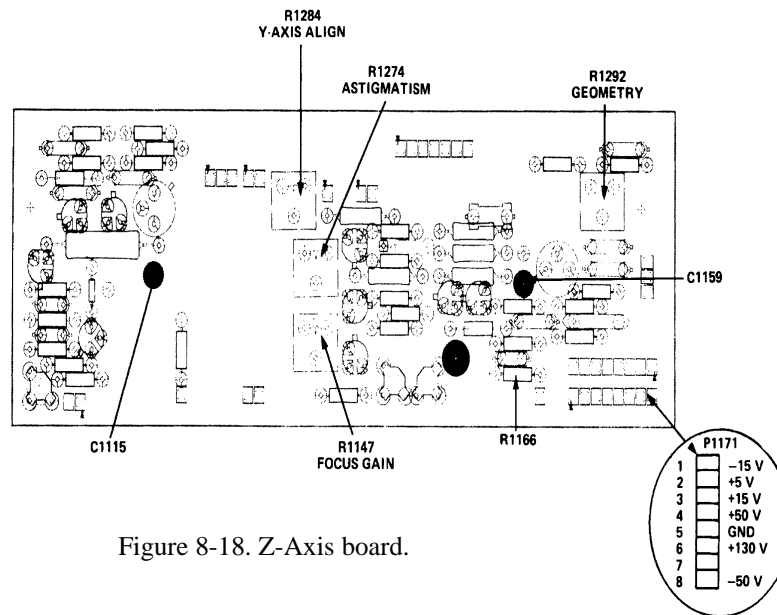
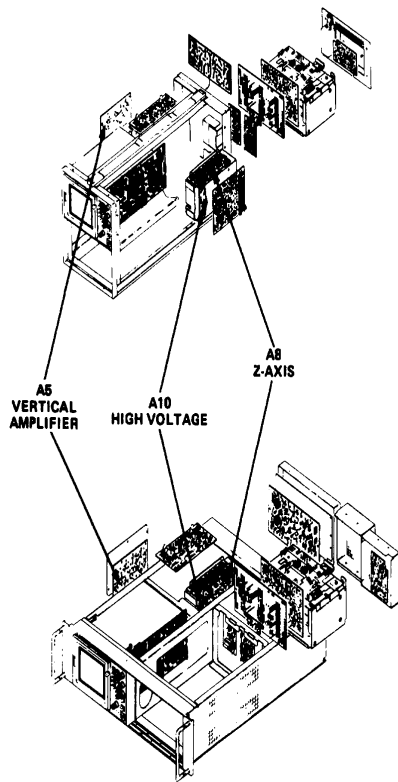

Figure 8-18. Z-Axis board.

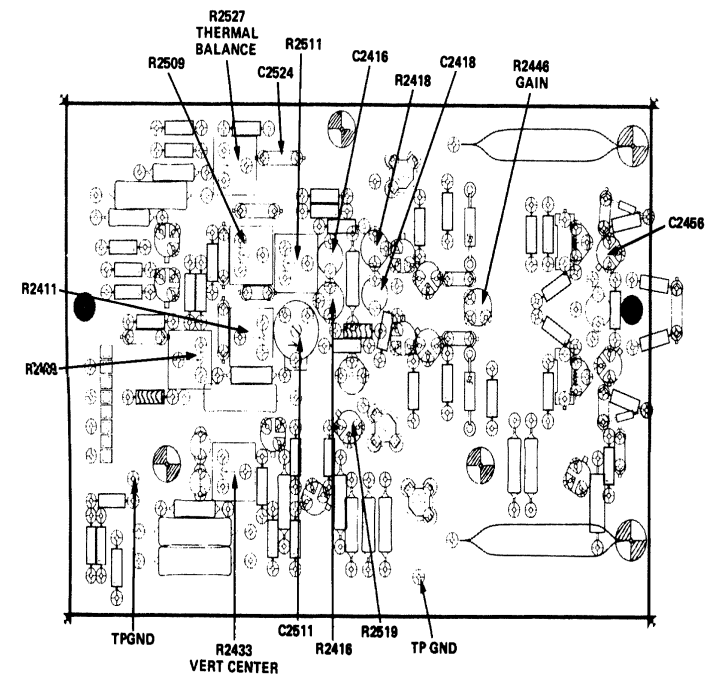

Figure 8-20. Vertical Amplifier board

MORE

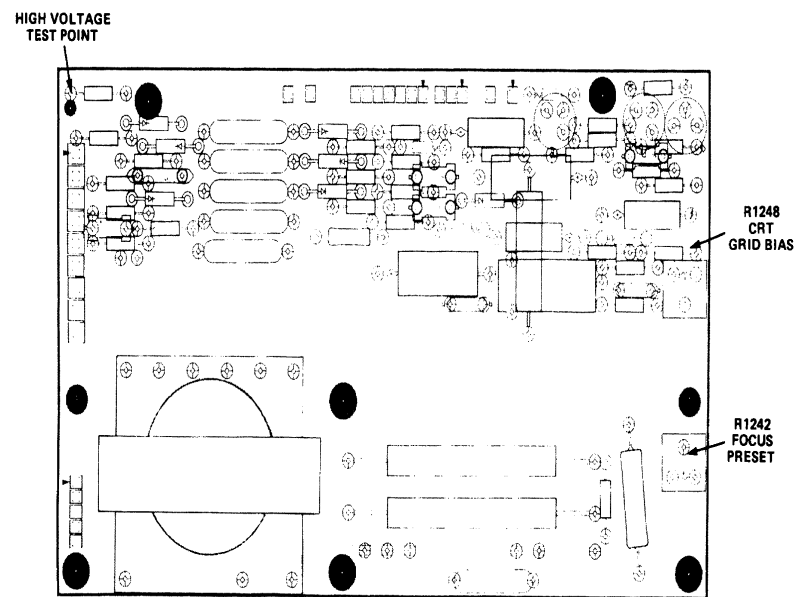

Figure 8-19. High Voltage board.

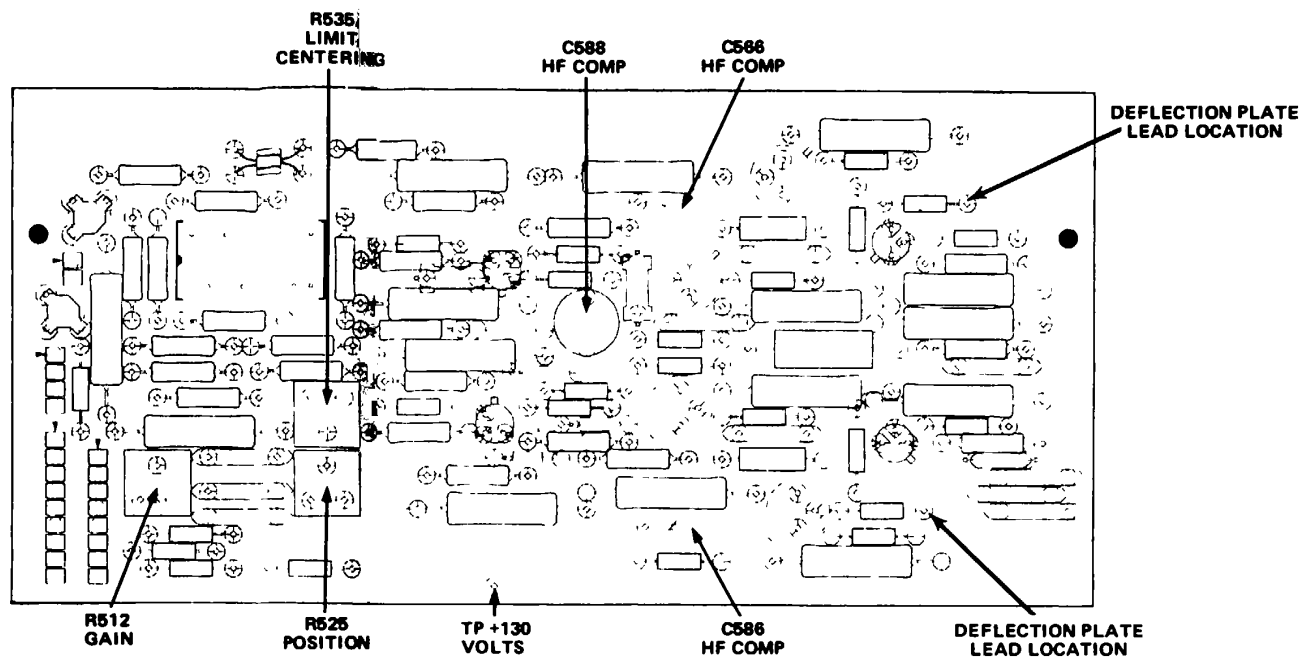
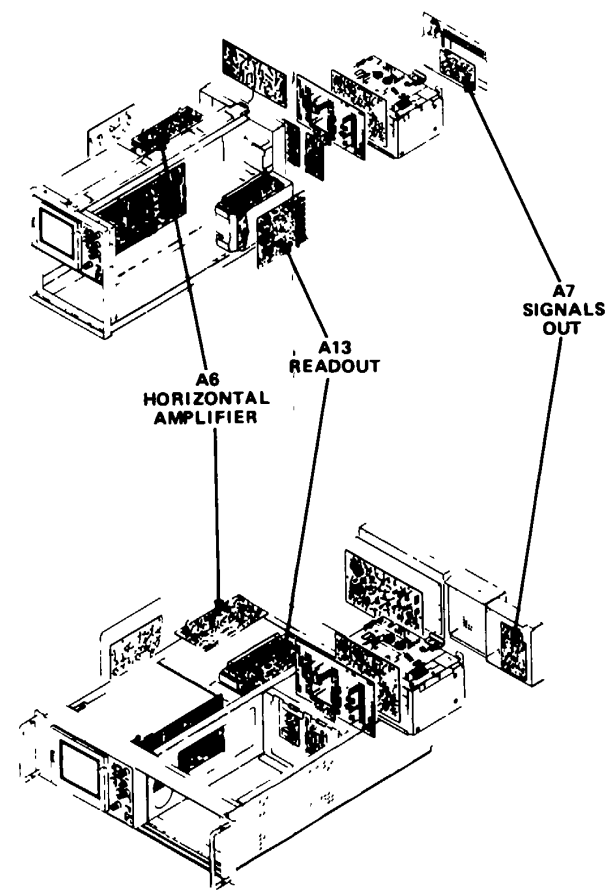

Figure 8-21. Horizontal Amplifier board.

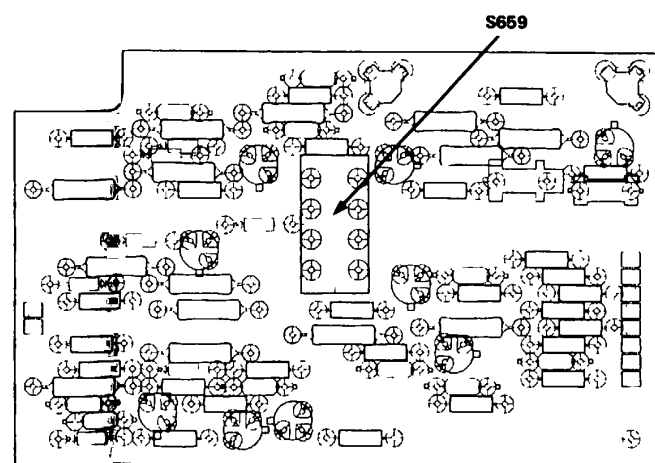

Figure 8-22. Signals Out board.

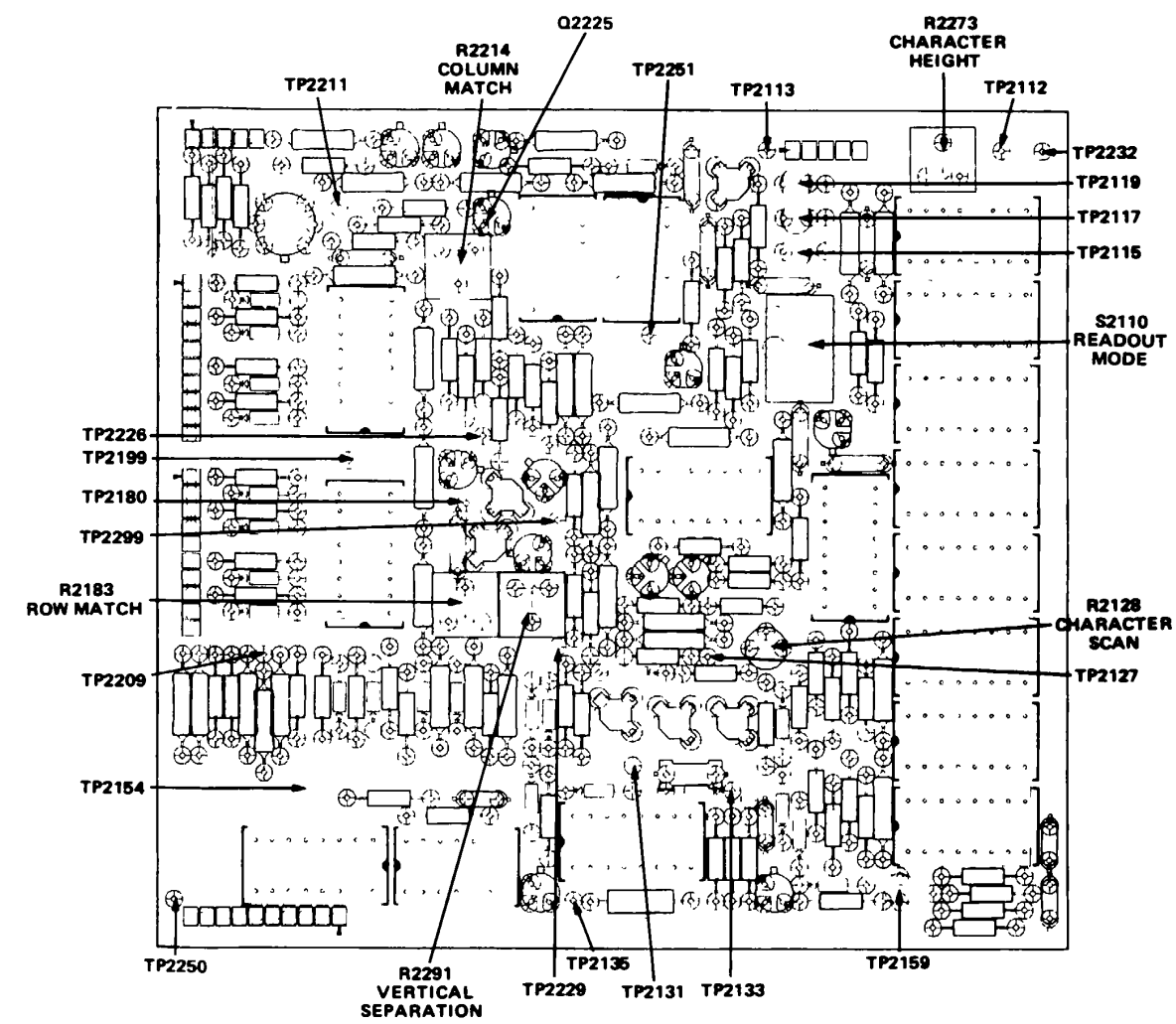
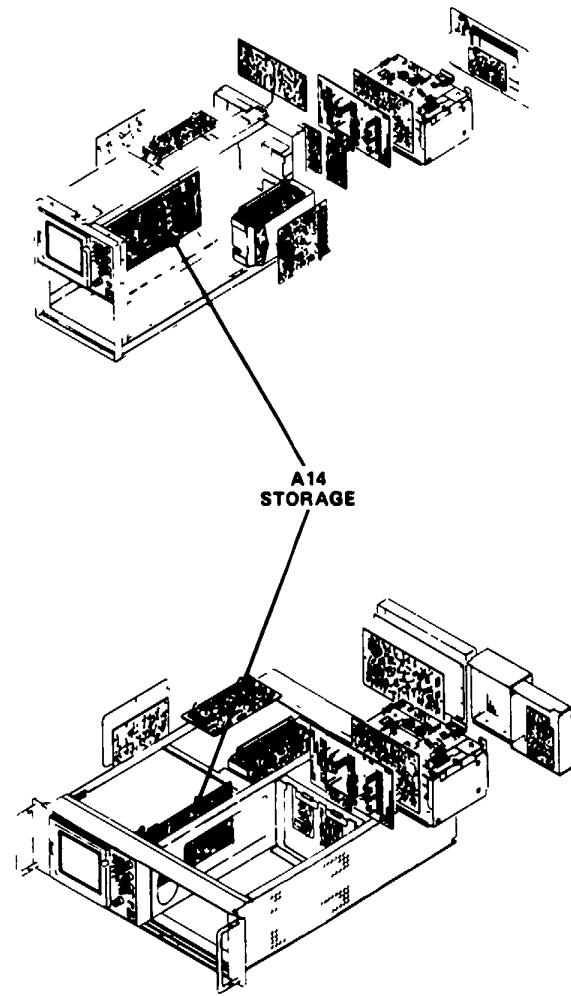

Figure 8-23. Readout board.



MORE 

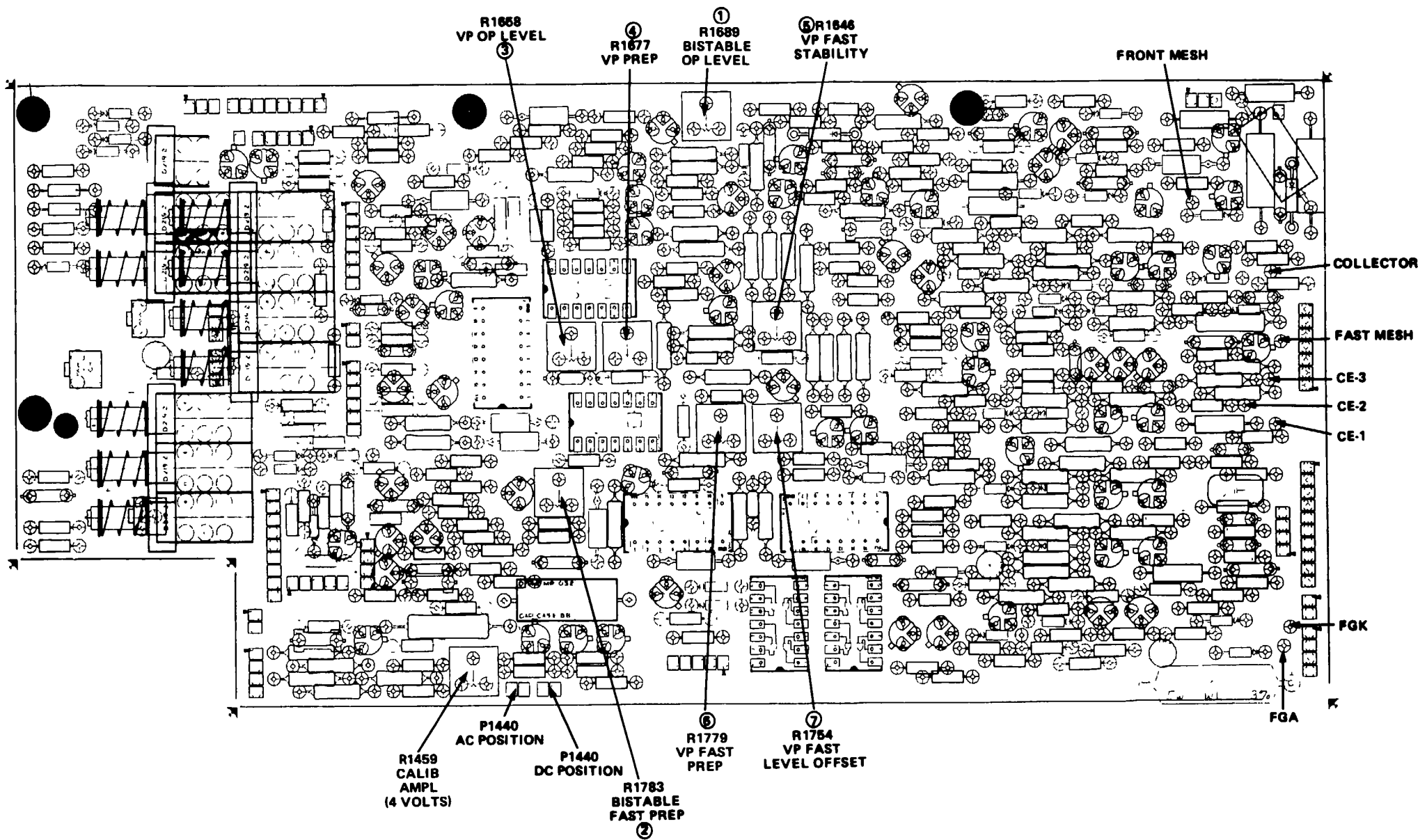
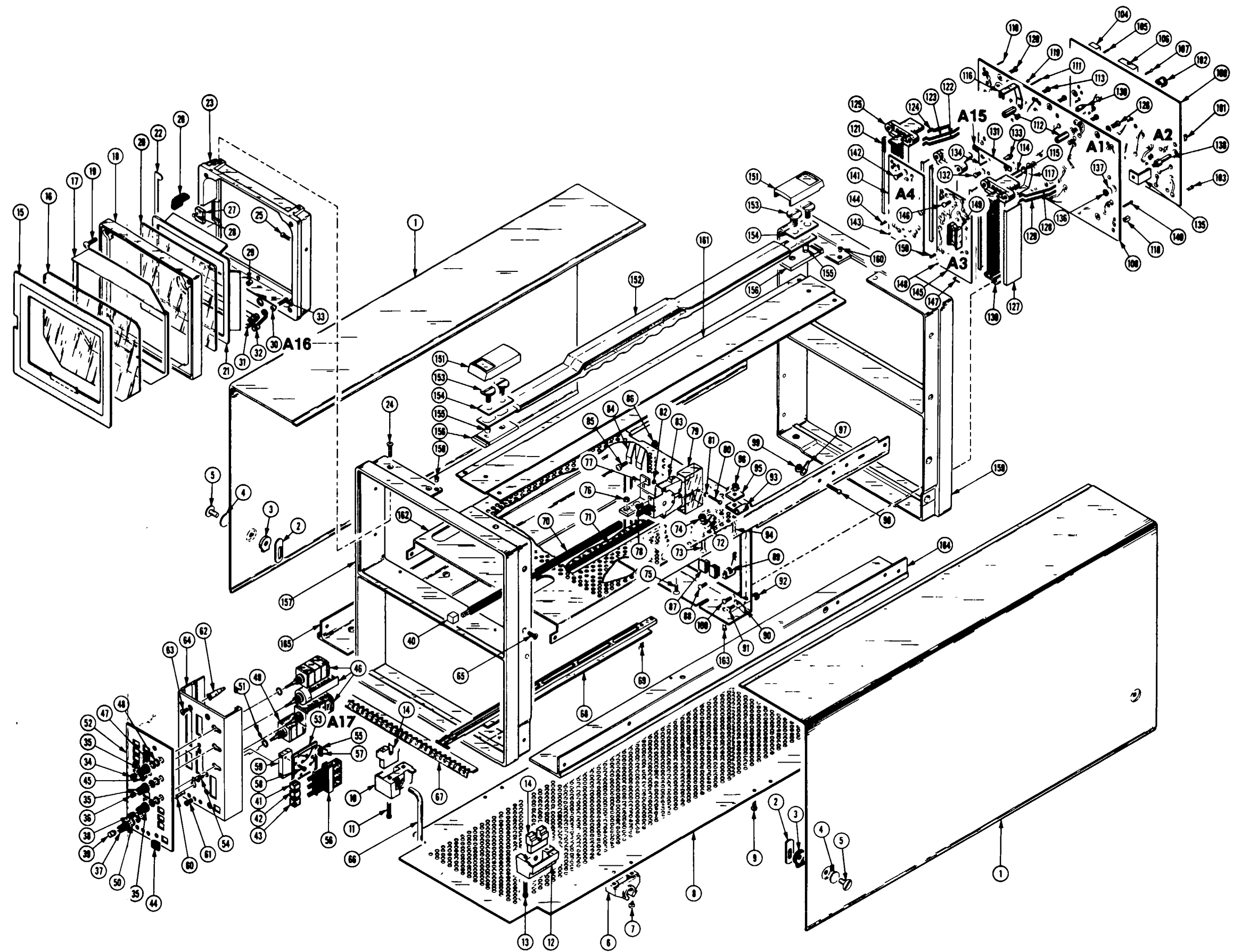
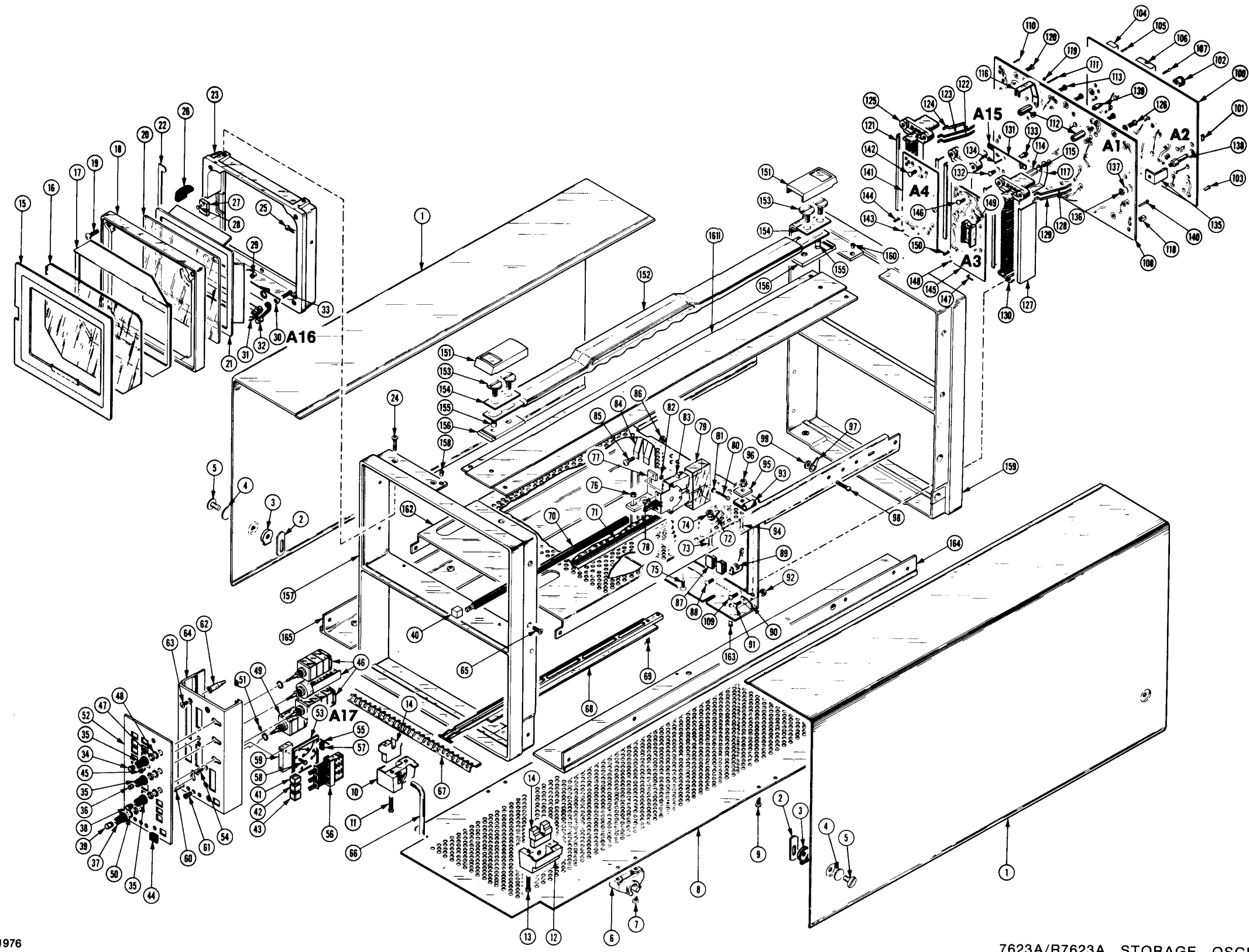

Figure 8-24. Storage board.





REV. B MAY 1976

7623A/R7623A STORAGE OSCILLOSCOPE

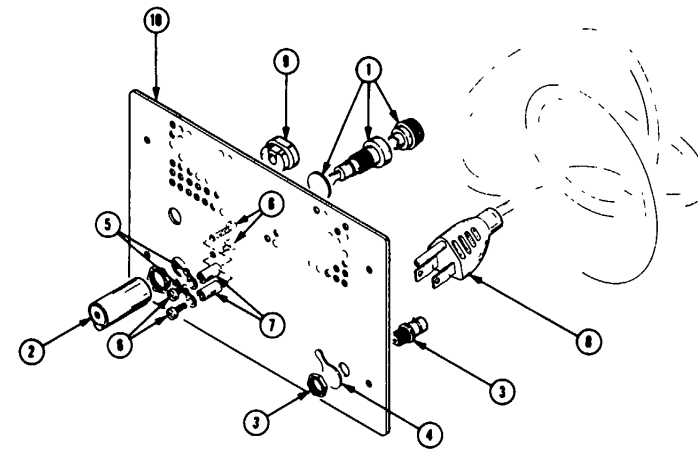

Fig. & Index No.	Tektronix Part No.	Serial/Model No. Eff	Qty	1	2	3	4	5	Name & Description	Mfr Code	Mfr Part Number
-1	352-0076-00		1						FUSEHOLDER:	75915	342012
-2	200-1388-00		1						COVER, FUSE:	80009	200-1388-00
-3	131-0955-00		1						CONNECTOR, RCPT: BNC FEMALE	24931	28JR200-1
-4	210-0255-00		1						TERMINAL, LUG: 0.391 INCH DIA	80009	210-0255-00
-5	210-0201-00		2						TERMINAL, LUG: SE #4	78189	2104-04-00-2520N
-6	211-0008-00		4						SCREW, MACHINE: 4-40 x 0.25 INCH, PNH STL	83385	OBD
-7	385-0149-00		2						INS STANDOFF:	80009	385-0149-00
-8	161-0033-09		1						CABLE ASSY, FWR: 3 WIRE 92 INCH LONG	70903	KH8035
-9	358-0323-00		1						BSHG STRAIN RLF:	28520	SR15-1
-10	386-2329-00		1						PANEL, REAR:	80009	386-2329-00

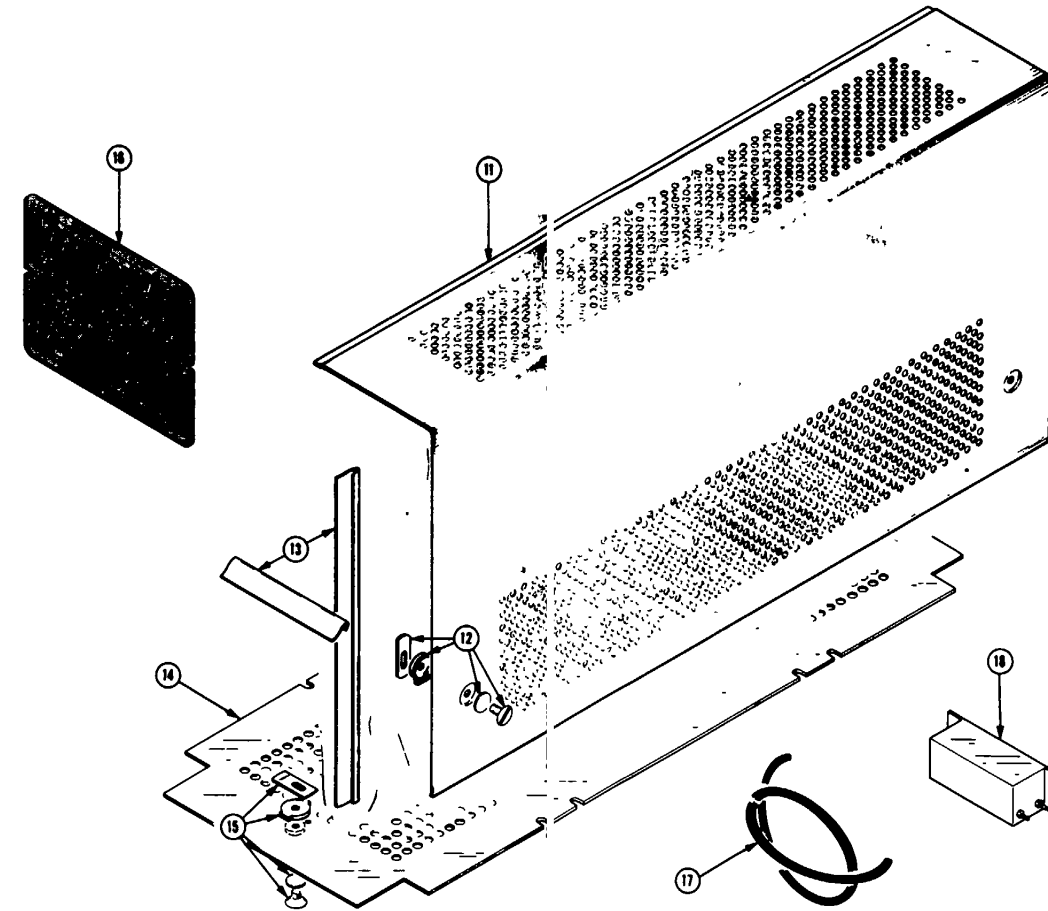
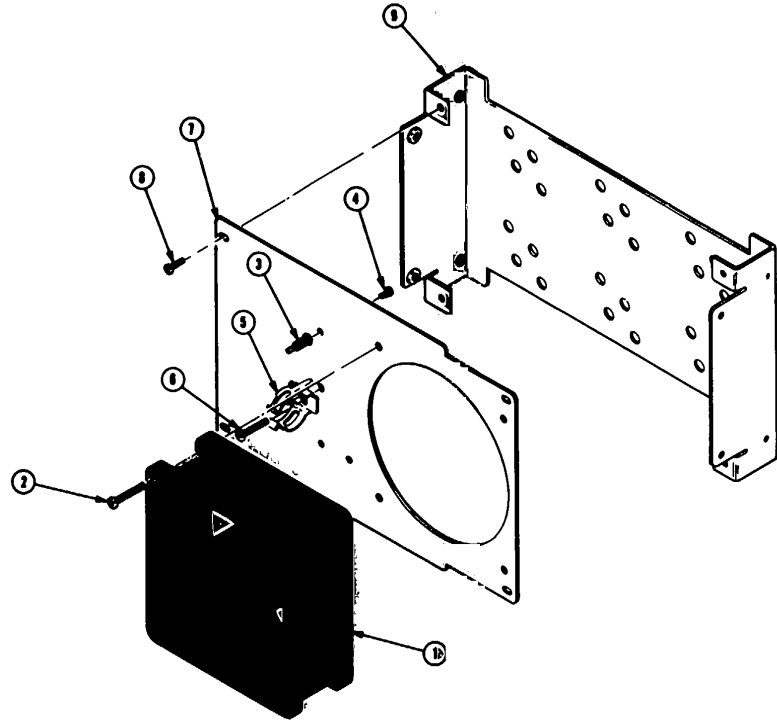

Fig & Index No	Tektronix Part No	Serial/Model No Eff	Qty	1	2	3	4	5	Name & Description	Mfr Code	Mfr Part Number
-11	390-0346-00		2						CABINET, SIDE:	80009	390-0346-00
-12	214-0816-00		6						LATCH ASSEMBLY:	80009	214-0816-00
-13	348-0274-01		4						SHLDG GSKT, ELECT: 48 INCHES LONG	80009	348-0274-01
-14	390-0355-00		1						CABINET, BOTTOM	80009	390-0355-00
-15	214-0816-00		2						LATCH ASSEMBLY:	80009	214-0816-00
-16	378-0603-00		1						FILTER, CRT:	80009	378-0603-00
-17	348-0234-00		1						SHLDG GSKT, ELE: 39.50 INCHES LONG	80009	348-0234-00
-18	119-0113-05		1						FIL RAD INTE:	72982	9604-000-9000
									OPTIONAL ACCESSORY FOR EMI		
	016-0155-00		1						PLUG-IN PANEL: BLANK	80009	016-0155-00

7623A/R7623A STORAGE OSCILLOSCOPE

7623A OPTION 5



R7623A OPTION 5

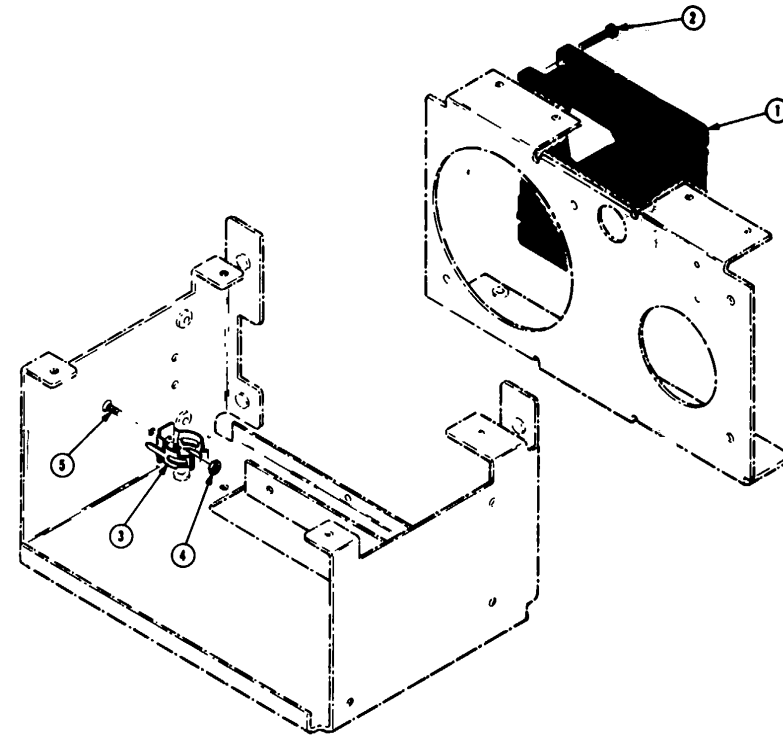

Fig & Index No	Tektronix Part No.	Serial/Model No Eff	Dscont	Qty	1	2	3	4	5	Name & Description	Mfr Code	Mfr Part Number
-1	-----			1						FAN, TUBE AXIAL: 50-400HZ, 115V, AC (SEE B1001 EPL) (ATTACHING PARTS)		
-2	211-0530-00			4						SCREW, MACHINE: 6-32 X 1.75 INCH, PNH STL	83385	OBD
-3	131-0761-00			3						TERMINAL STUD: SCREW MTD, FLAT TAB (ATTACHING PARTS FOR EACH)	71279	4897-1-0516
-4	211-0504-00			1						SCREW, MACHINE: 6-32 X 0.25 INCH, PNH STL	83385	OBD
-5	344-0116-00			1						RTNR, CAPACITOR (ATTACHING PARTS)	TH-17	90210
-6	211-0008-00			1						SCREW, MACHINE: 4-40 X 0.25 INCH, PNH STL	83385	OBD
-7	378-0050-00			1						BAFFLE, AIR: (ATTACHING PARTS)	80009	378-0050-00
-8	211-0507-00			4						SCREW, MACHINE: 6-32 X 0.312 INCH, PNH STL	83385	OBD
-9	441-1201-00			1						CHAS, ELEC EQPT	80009	441-1201-00

Fig & Index No	Tektronix Part No.	Serial/Model No Eff	Dscont	Qty	1	2	3	4	5	Name & Description	Mfr Code	Mfr Part Number
-1	-----			1						FAN, TUBE AXIAL: 50-400HZ, 115V, AC (SEE B1001 EPL) (ATTACHING PARTS)		
-2	211-0530-00			4						SCREW, MACHINE: 6-32 X 1.75 INCH, PNH, STL	83385	OBD
-3	344-0116-00			1						RTNR, CAPACITOR (ATTACHING PARTS)	TH-17	90210
-4	210-0407-00			1						NUT, PLAIN, HEX: 6-32 X 0.25 INCH, BRS	73743	3038-0228-402
-5	211-0541-00			1						SCREW, MACHINE: 6-32 X 0.25 INCH, 100 DEG, FLH STL	83385	OBD

R7623A

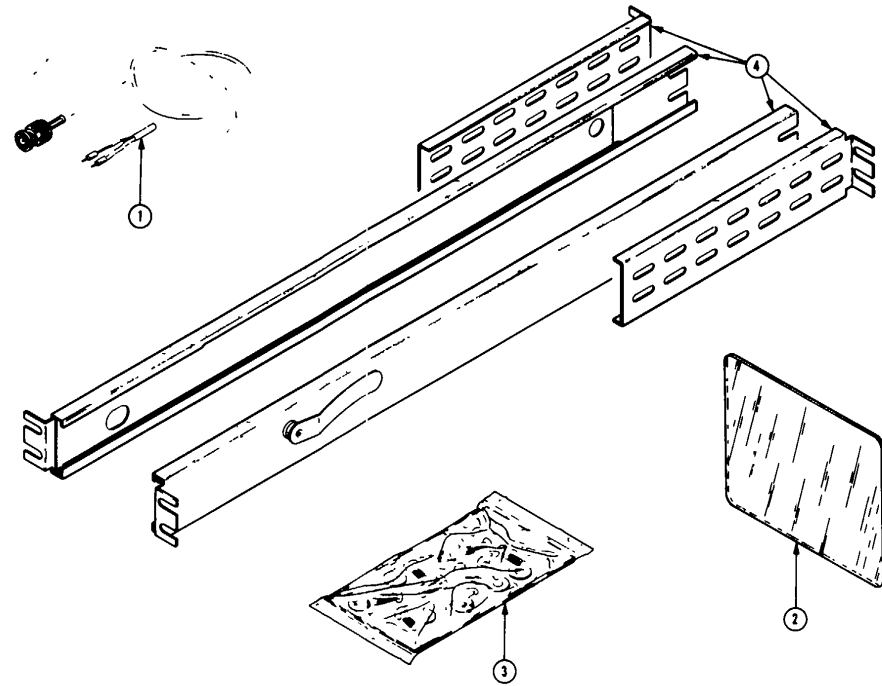

Fig. & Index No.	Tektronix Part No.	Serial/Model No. Eff	Qty	Name & Description					Mfr	
				1	2	3	4	5	Code	Mfr Part Number
-1	175-1178-00		2	CABLE, SPL PURP:					80009	175-1178-00
-2	378-0625-08		1	FILTER, LIGHT:					80009	378-0625-08
-3	016-0131-00		1	HARDWARE, KIT:					80009	016-0131-00
-4	351-0314-00		1	SLIDE-GUIDE:19.25 INCHES LONG					80009	351-0314-00
	070-1362-00		1	MANUAL, TECH:OPERATOR'S					80009	070-1362-00
	070-1363-00		1	MANUAL, TECH:SERVICE					80009	070-1363-00

7623A

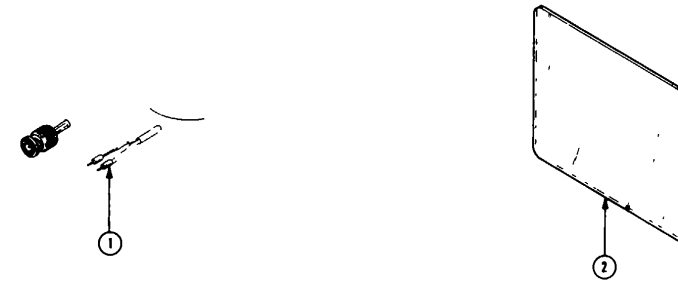
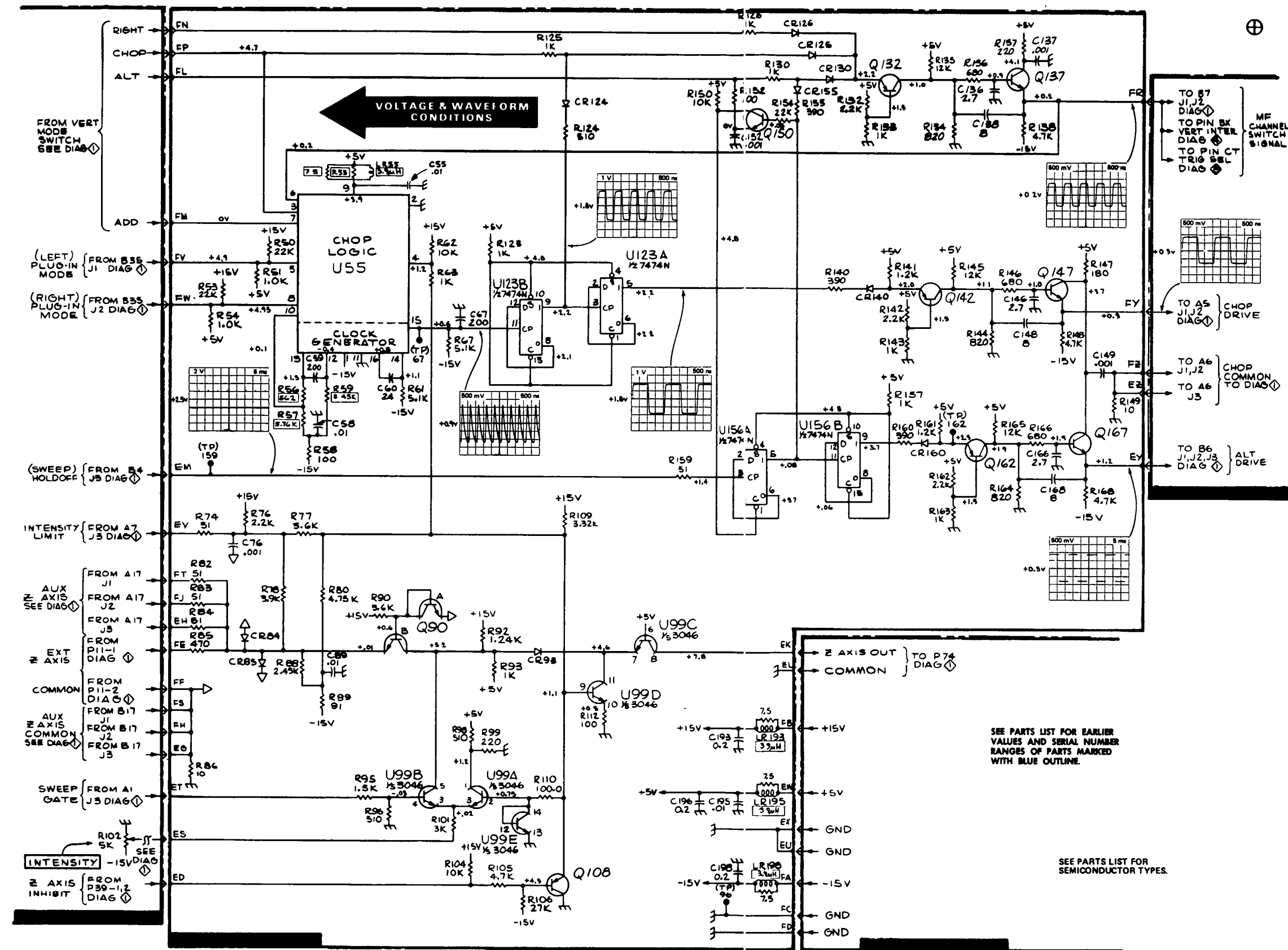

Fig. & Index No.	Tektronix Part No.	Serial/Model No. Eff	Qty	Name & Description					Mfr	
				1	2	3	4	5	Code	Mfr Part Number
6-1	175-1178-00		2	CABLE, SPL PURP:					80009	175-1178-00
-2	378-0625-08		1	FILTER, LIGHT:GREEN					80009	378-0625-08
	070-1684-00		1	MANUAL, TECH:OPERATOR'S (NOT SHOWN)					80009	070-1684-00
	070-1685-00		1	MANUAL, TECH:SERVICE (NOT SHOWN)					80009	070-1685-00



VOLTAGES AND WAVEFORMS

The voltages and waveforms shown on this diagram were obtained using the recommended test equipment and test set-ups listed below.

RECOMMENDED TEST EQUIPMENT

ITEM	SPECIFICATIONS	RECOMMENDED TYPE
Oscilloscope	Frequency response DC to 65 MHz Deflection factor 5 mV to 5 V/Div Input impedance 10 MΩ, 20 pF Sweep rate 500 ns	Tektronix 7803 or 7813 equipped with 7A15A Amplifier and 7B53A Time-Base unit, or equivalent. A 7A13 Differential Comparator was used to obtain offset.
Probe	Fast rise 10X attenuation probe compatible with the vertical amplifier of the test oscilloscope.	Tektronix P6053B, or equivalent.
Voltmeter (Non-Loading Digital Multimeter)	Input impedance 10 MΩ Range 0 to 500 V	Tektronix 7D13 Digital Multimeter (test oscilloscope must have readout system) or Tektronix DM 501 Digital Multimeter with power module, or equivalent.

VOLTAGE MEASUREMENTS

Voltage measurements on this diagram were made under the following conditions:
 Set front panel controls (knob type) to mid-range.
 Set VERT MODE for CHOP.
 Set TRIG SOURCE for VERT MODE.
 Set for NON STORE condition.
 No plug-in units are installed.
 Voltmeter common is connected to chassis ground.

WAVEFORMS

Waveforms shown on this diagram were obtained under the following conditions:
 7623A OSCILLOSCOPE UNDER TEST. Front panel controls are set the same as for voltage measurements. A 7A15A Amplifier unit and a 7B53A Time-Base unit are installed in the mainframe under test. The test oscilloscope 4 Volts calibrator signal is applied to the amplifier unit. The amplifier unit is set for 1 V/division deflection centered on the crt. The 7B53A is set for internal auto-trigger, 0.5 ms/division sweep rate.

TEST OSCILLOSCOPE. The test oscilloscope is externally triggered from the +GATE OUT (MAIN) of the 7623A mainframe under test. The test oscilloscope is dc coupled.

Tolerances of voltages and waveforms shown are 20%.

SEE PARTS LIST FOR EARLIER VALUES AND SERIAL NUMBER RANGES OF PARTS MARKED WITH BLUE OUTLINE.

SEE PARTS LIST FOR SEMICONDUCTOR TYPES.

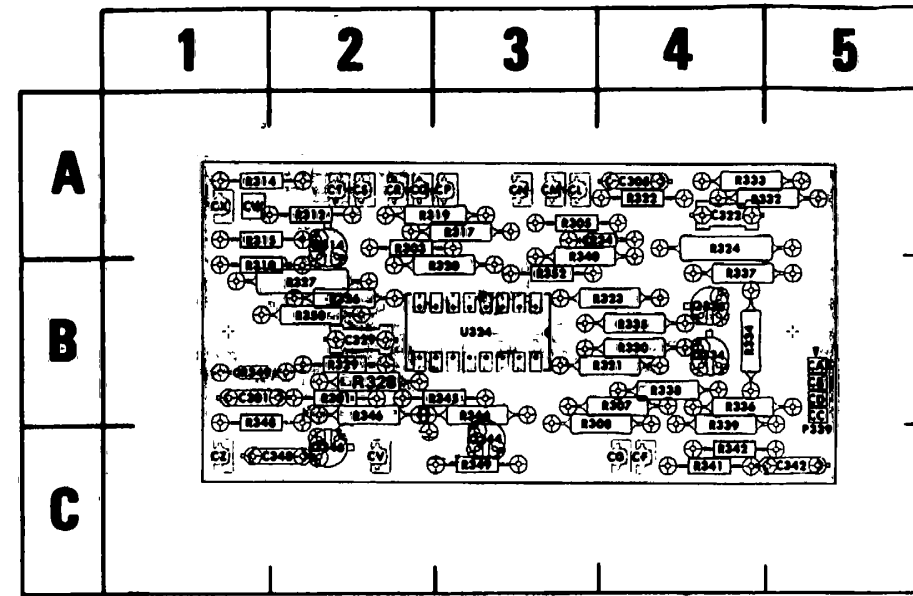
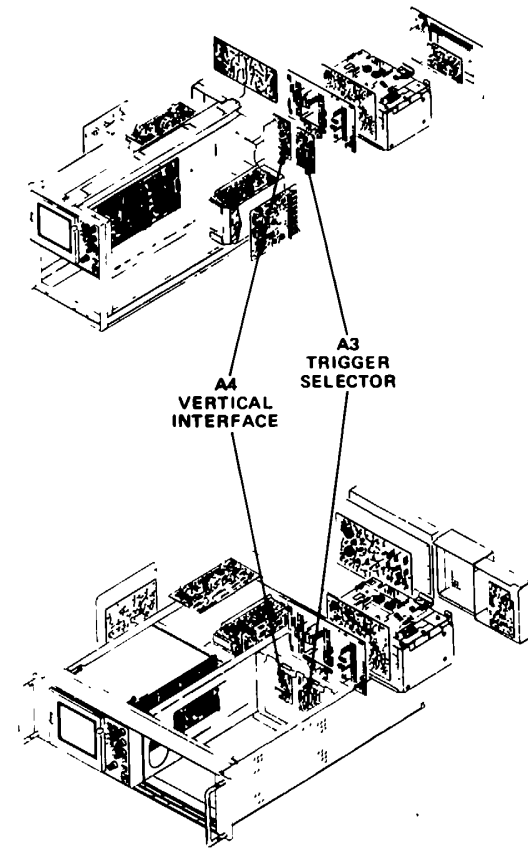

Figure 8-4. A3-Trigger Selector board.

CKT NO	GRID LOC	CKT NO	GRID LOC	CKT NO	GRID LOC	CKT NO	GRID LOC
C301	1B	Q344	3C	R322	4A	R340	3A
C306	4A	Q346	2C	R323	4B	R341	4C
C322	4A			R324	4A	R342	4C
C329	2B	R301	2B	R326	2B	R344	3B
C342	5C	R303	2A	R327	2B	R345	3B
C348	2C	R305	3A	R328	2B	R346	2B
		R307	4B	R329	2B	R348	1B
		R308	3B	R330	4B	R349	3C
CR341	4A	R310	1B	R332	4A	R360	2B
CR340	1B	R312	2A	R333	4A	R362	3B
		R314	1A	R334	4B		
P339	5C	R315	1A	R336	4B	U324	3B
		R317	3A	R338	4B		
Q314	2A	R319	3A	R337	4B		
Q334	4B	R320	3B	R338	4B		
Q336	4B	R321	4B	R339	4B		

Ⓐ

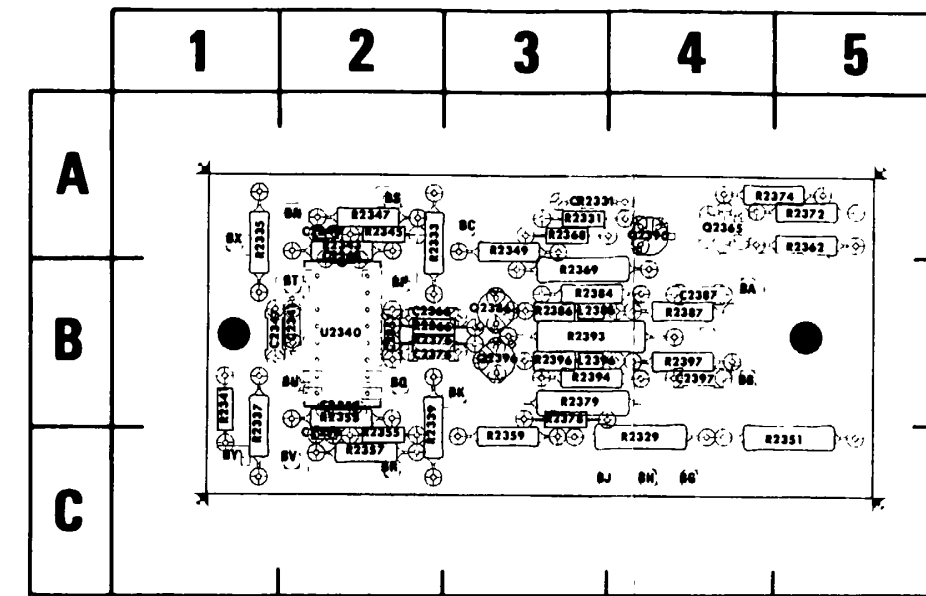

Figure 8-5. A4-Vertical Interface board.

CKT NO	GRID LOC	CKT NO	GRID LOC	CKT NO	GRID LOC	CKT NO	GRID LOC
C2341	2B	L2396	3B	R2347	2A	R2384	3B
C2345	2A			R2349	3A	R2386	3B
C2347	1B	Q2365	4A	R2351	5C	R2387	4B
C2348	2A	Q2306	3B	R2353	2B	R2393	3B
C2355	2C	Q2390	4A	R2355	2C	R2394	3B
C2357	2B	Q2396	3B	R2357	2C	R2396	3B
C2358	2B			R2359	3C	R2397	4B
C2366	2B	R2235	1A	R2362	5A		
C2376	2B	R2329	4C	R2366	2B	U2340	2B
C2387	4B	R2331	3A	R2368	3A		
C2397	4B	R2333	2A	R2369	3B		
		R2337	1B	R2372	5A		
		R2339	2B	R2375	5A		
CR2331	3A	R2341	1B	R2376	2B		
		R2343	2A	R2378	3B		
L2386	3B	R2345	2A	R2379	3B		

Ⓐ

VOLTAGES AND WAVEFORMS

The voltages and waveforms shown on this diagram were obtained using the recommended test equipment and test set-ups listed below

ITEM	RECOMMENDED TEST EQUIPMENT		
	SPECIFICATIONS	RECOMMENDED TYPE	
Oscilloscope	Frequency response Deflection factor Input impedance Sweep rate	DC to 65 MHz 5 mV to 5 V/Div 10 M Ω , 20 pF 500 ns	Tektronix 7603 or 7613 equipped with 7A15A Amplifier and 7B53A Time-Base unit, or equivalent. A 7A13 Differential Comparator was used to obtain offset.
Probe	Fast rise 10X attenuation probe compatible with the vertical amplifier of the test oscilloscope.	Tektronix P6053B, or equivalent	
Voltmeter (Non-Loading Digital Multimeter)	Input impedance Range	10 M Ω 0 to 500 V	Tektronix 7D13 Digital Multimeter (test oscilloscope must have readout system) or Tektronix DM 501 Digital Multimeter with power module, or equivalent.

VOLTAGE MEASUREMENTS

Voltage measurements on this diagram were made under the following conditions:
 Set front panel controls (knob type) to mid-range
 Set VERT MODE for CHOP.
 Set TRIG SOURCE for VERT MODE.
 Set for NON STORE condition.
 No plug-in units are installed.
 Voltmeter common is connected to chassis ground.

WAVEFORMS

Waveforms shown on this diagram were obtained under the following conditions:
 7623A OSCILLOSCOPE UNDER TEST. Front panel controls are set the same as for voltage measurements. A 7A15A Amplifier unit and a 7B53A Time-Base unit are installed in the mainframe under test. The test oscilloscope 4 Volts calibrator signal is applied to the amplifier unit. The amplifier unit is set for 1 V/division deflection centered on the crt. The 7B53A is set for internal auto-trigger, 0.5 ms/division sweep rate.

TEST OSCILLOSCOPE. The test oscilloscope is externally triggered from the +GATE OUT (MAIN) of the 7623A mainframe under test. The test oscilloscope is dc coupled.

Tolerances of voltages and waveforms shown are 20%

VOLTAGE & WAVEFORM CONDITIONS

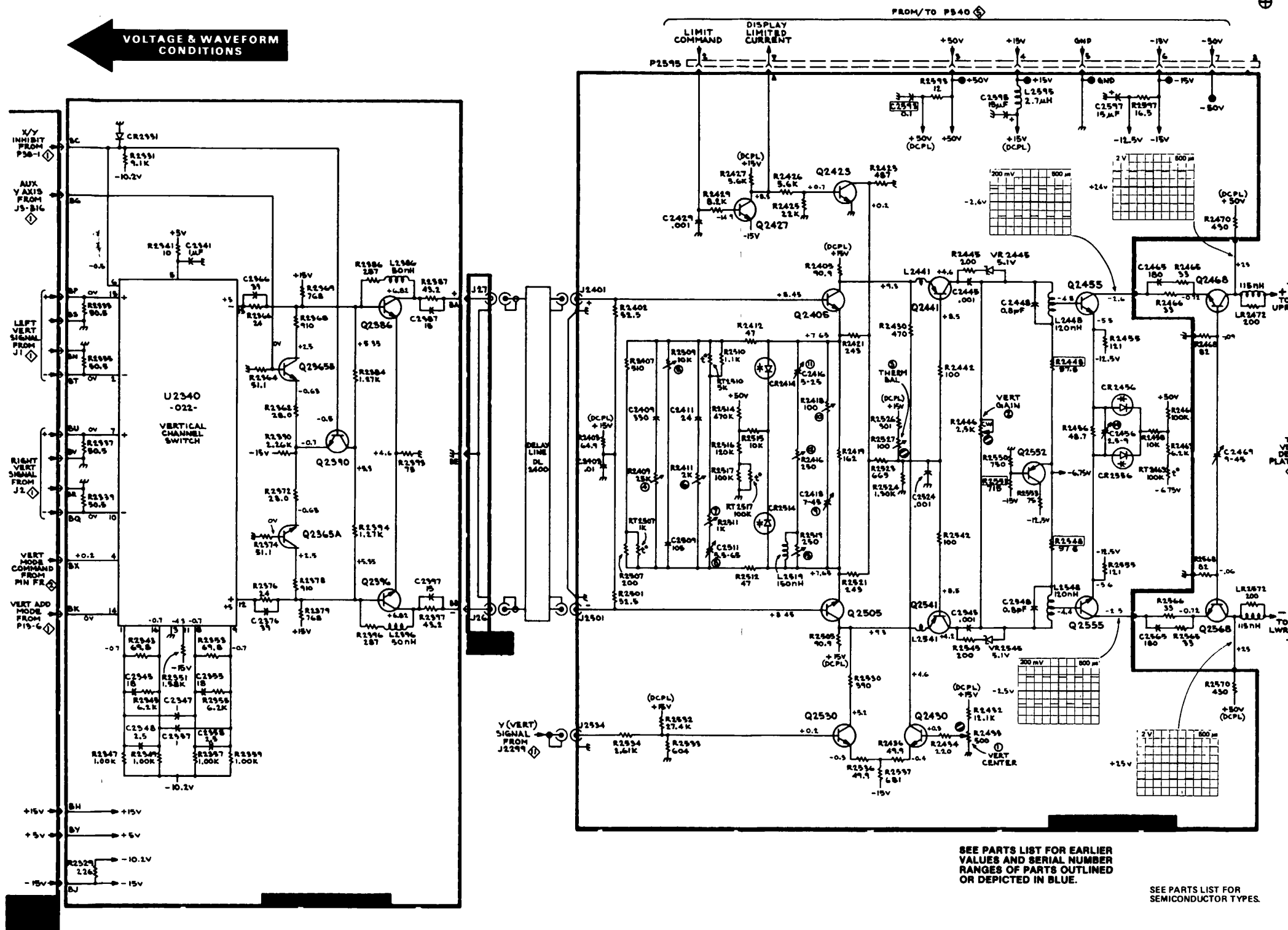

SEE PARTS LIST FOR EARLIER VALUES AND SERIAL NUMBER RANGES OF PARTS OUTLINED OR DEPICTED IN BLUE.

SEE PARTS LIST FOR SEMICONDUCTOR TYPES.

VERTICAL INTERFACE AMPLIFIER

7623A

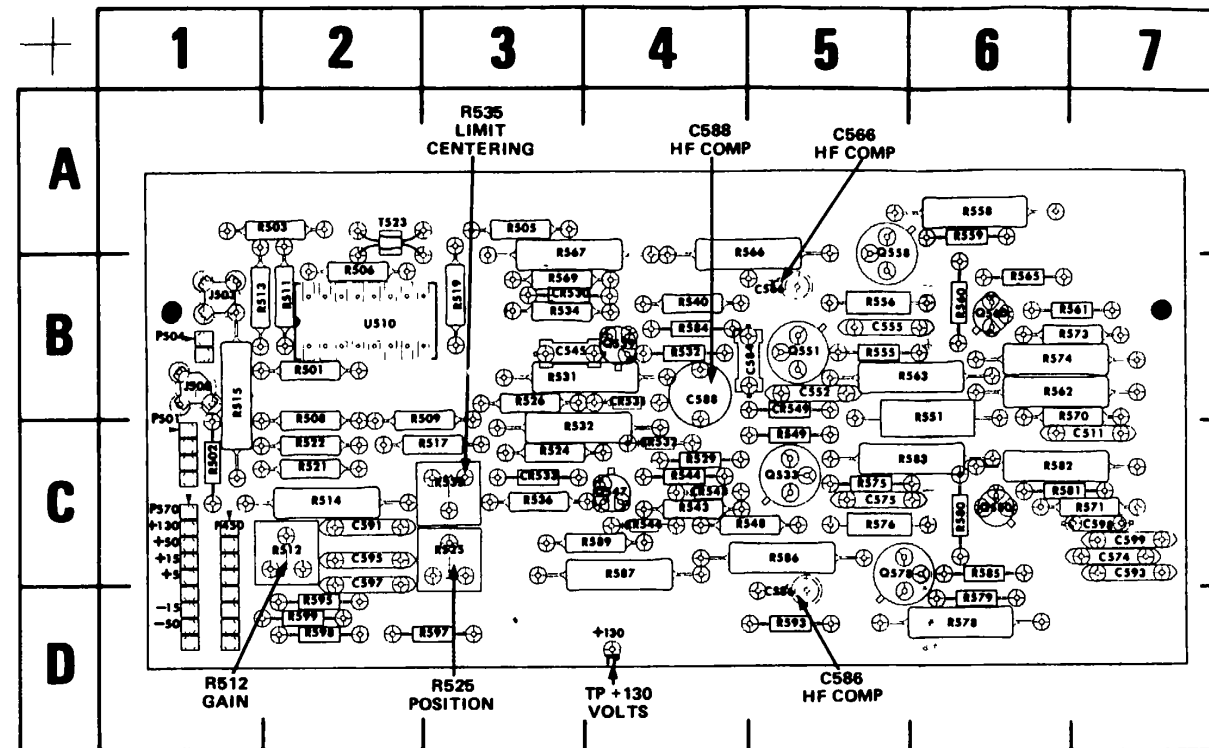
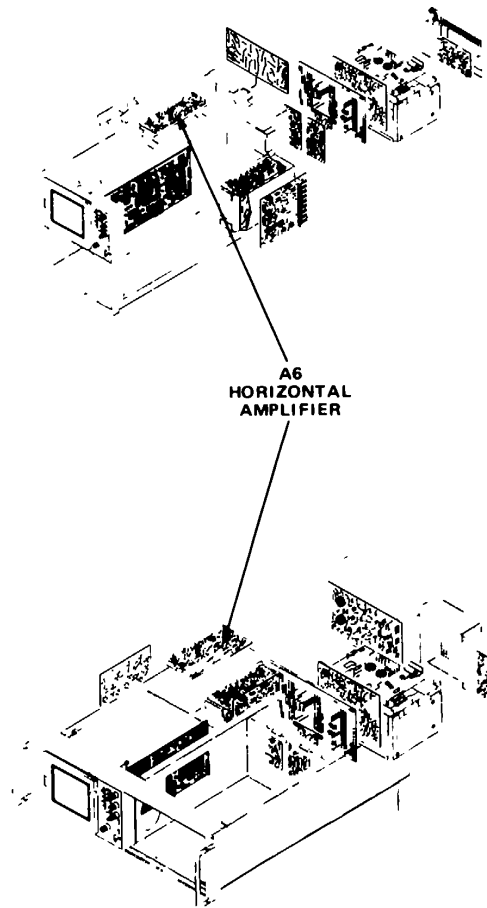

Figure 8-8. A6-Horizontal Amplifier board.

CKT NO	GRID LOC	CKT NO	GRID LOC	CKT NO	GRID LOC	CKT NO	GRID LOC	CKT NO	GRID LOC
C511	7B	CR549	5B	R506	2B	R536	3C	R575	5C
C545	3B			R508	2B	R540	4B	R576	5C
C552	5B	J503	1B	R509	2B	R543	4C	R578	6D
C555	5B	J508	1B	R511	2B	R544	4C	R579	6C
C566	5B			R512	2C	R548	4C	R580	6C
C574	7C	P450	1C	R513	1B	R549	5C	R581	6C
C575	5C	P501	1B	R514	2C	R551	6B	R582	6C
C584	4B	P504	1B	R515	1B	R555	5B	R583	5C
C586	5C	P670	1C			R556	5B	R584	4B
C588	4B			R517	3C	R558	6A	R585	6C
C591	2C					R559	6A	R586	5C
C593	7C	Q533	5C	R519	3B	R560	6B	R587	4C
C595	2C	Q539	4B			R561	6B	R589	4C
C597	2C	Q547	4C	R521	2C	R562	6B	R593	5D
C598	7C	Q551	5B	R522	2C	R563	5B	R595	2D
C599	7C	Q558	5A	R524	3C	R565	6B	R597	3D
		Q660	6B	R525	3C	R566	4A	R598	2D
		Q678	5C	R526	3B	R567	3A	R599	2D
CR530	3B	Q680	6C	R529	4C	R569	3B		
CR531	4B	R501	2B	R531	3B	R570	6B	T523	2A
CR532	4C	R502	1C	R532	4B	R571	7C		
CR533	3C	R503	2A	R534	3B	R573	6B	U510	2B
CR543	4C	R505	3A	R535	3C	R574	6B		
CR544	4C								

MORE



VOLTAGES AND WAVEFORMS
 The voltages and waveforms shown on this diagram were obtained using the recommended test equipment and test set-ups listed below

ITEM	RECOMMENDED TEST EQUIPMENT SPECIFICATIONS	RECOMMENDED TYPE
Oscilloscope	Frequency response DC to 85 MHz Deflection factor 5 mV to 5 V/Div Input impedance 10 MΩ, 20 pF Sweep rate 500 ns	Tektronix 7603 or 7613 equipped with 7A22 Amplifier and 7B53A Time-Base unit, or equivalent
Probe	Fast rise 10X attenuation probe compatible with the vertical amplifier of the test oscilloscope	Tektronix P6053B, or equivalent
Voltmeter (Non-Loading Digital Multimeter)	Input impedance 10 MΩ Range 0 to 500 V	Tektronix 7D13 Digital Multimeter (test oscilloscope must have readout system) or Tektronix DM 501 Digital Multimeter with power module, or equivalent
Calibration Fixture	Used for loading power supply for ripple waveforms.	Tektronix Signal Standardizer, Tektronix Part Number 067-0587-01, or equivalent

VOLTAGE MEASUREMENTS
 Voltage measurements on the diagram were made under the following conditions
 Set knob type front panel controls (except READOUT) to mid-range
 Turn READOUT to off
 Set VERT MODE for CHOP.
 Set for NON STORE condition.
 Set TRIG SOURCE for VERT MODE.
 No plug-ins are installed.
 Voltmeter common is connected to chassis ground

WAVEFORMS
 Waveforms shown on this diagram were obtained under the following conditions
 7623A OSCILLOSCOPE UNDER TEST. Front panel controls are set the same as for voltage measurements. A signal standardizer unit is installed in a vertical compartment and a 7B53A Time Base unit in the horizontal compartment. The signal standardizer is used for power supply loading and is set for AUX IN with a REP RATE of 100 Hz. No signal is applied. The 7B53A is set for internal auto-trigger, 0.5 ms/division sweep rate

TEST OSCILLOSCOPE The test oscilloscope is ac coupled and set for LINE trigger. A 7A22 Amplifier unit is installed and set as follows
 HF -3 dB POINT 30kHz
 LF -3 dB point DC
 +INPUT AC
 -INPUT GND

Tolerances of voltages and waveforms shown are 20%

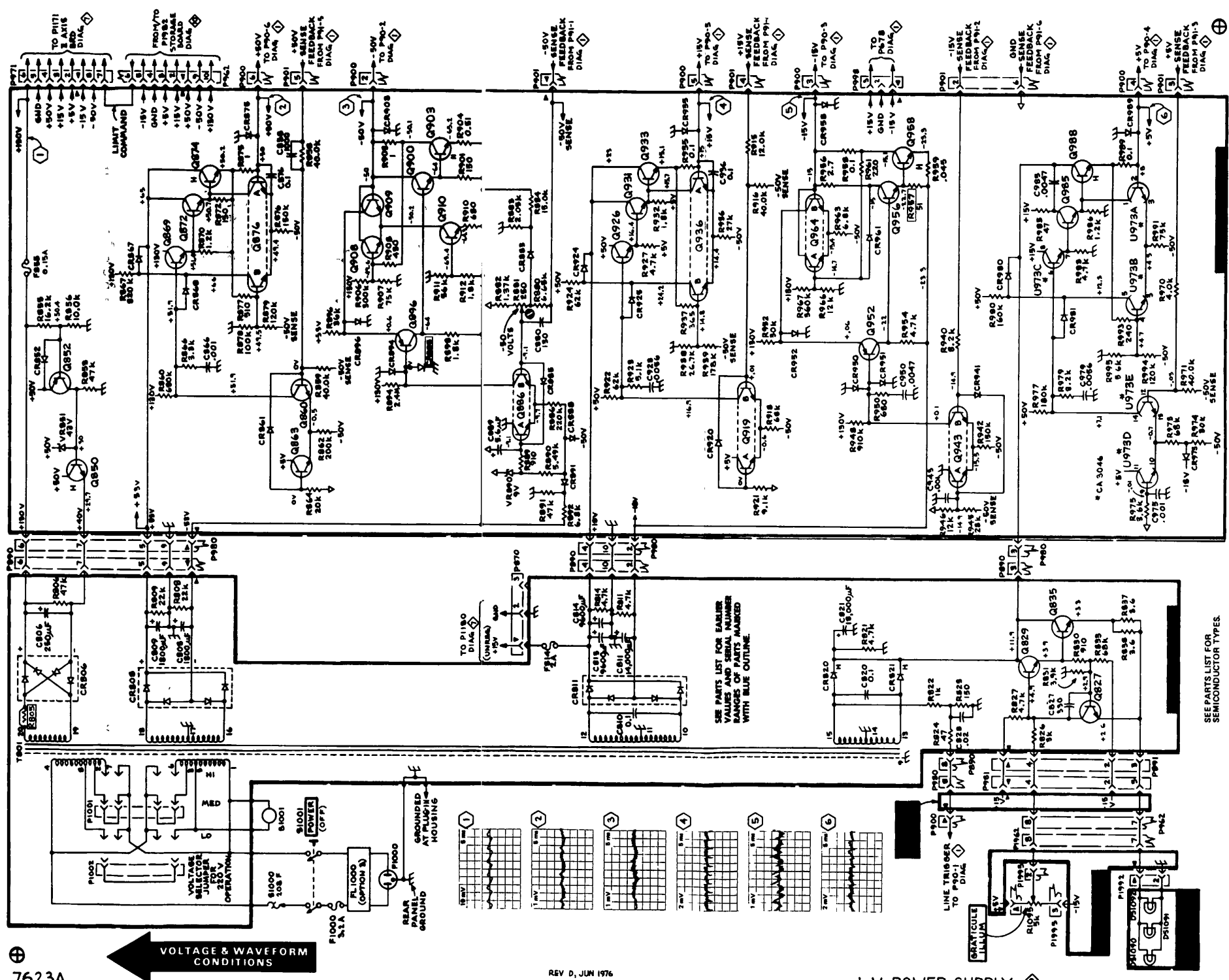

7623A

VOLTAGE & WAVEFORM CONDITIONS

REV D, JUN 1976

LV POWER SUPPLY

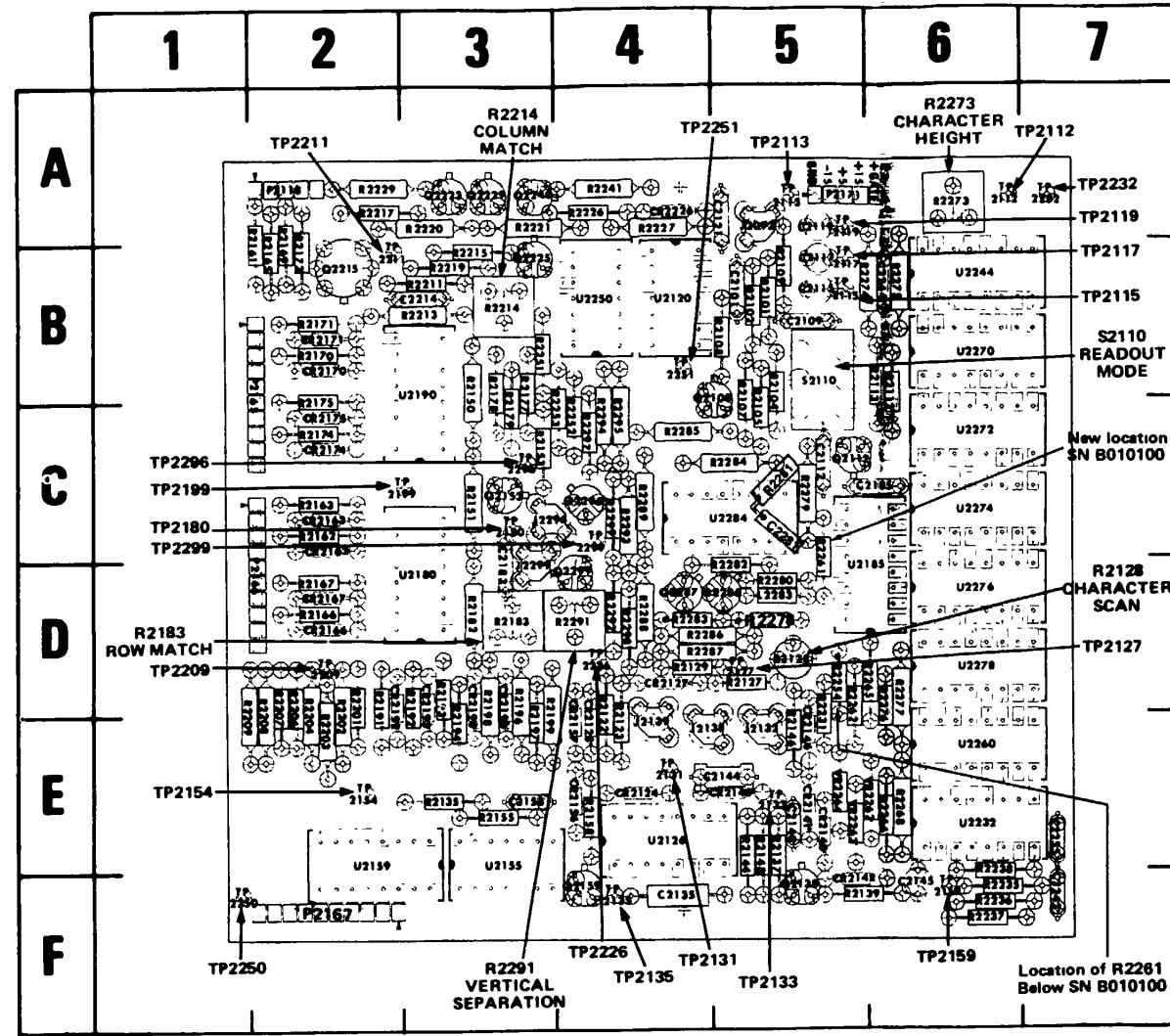

*See Parts List for serial number ranges

Figure 8-15. A13-Readout board.

COMPONENT LOCATION INDEX

CKT NO	GRID LOC	CKT NO	GRID LOC	CKT NO	GRID LOC	CKT NO	GRID LOC
C2101	5B	P2166	2D	R2182	3D	R2285	4C
C2109	5B	P2171	5A	R2183	3D	R2286	4D
C2112	5C			R2185	3E	R2287	4D
C2115	5B	Q2108	4C	R2191	2D	R2288	4C
C2117	5B	Q2112	5C	R2192	3D	R2289	4C
C2119	5A	Q2138	6F	R2193	3D	R2292	4D
C2121	5A	Q2163	3C	R2194	3E	R2291	4D
C2135	4F	Q2199	4F	R2196	3D	R2293	4C
C2140	5E	Q2215	2B	R2197	3D	R2294	4C
C2242	7F	Q2223	3A	R2198	3D	R2295	4C
C2144	5E	Q2225	3B	R2199	3D	R2297	4C
C2146	6F	Q2229	3A	R2201	2D	R2298	4D
C2155	3E	Q2240	3A	R2202	2D	R2299	4C
C2185	6C	Q2287	4D	R2203	2E	S2110	5B
C2183	3D	Q2296	4C	R2204	2D	TP2112	6A
C2214	3B	Q2299	4D	R2206	2D	TP2113	5A
C2244	6B			R2207	2D	TP2115	5B
C2255	7E	R2101	5B	R2208	2D	TP2117	5B
C2281	5C	R2102	5B	R2209	1E	TP2127	5D
C2286	5D	R2104	5B	R2211	3B	TP2119	5A
CR2124	4E	R2105	5C	R2213	3B	TP2127	5D
CR2125	4E	R2107	5C	R2214	3B	TP2131	4E
CR2127	4D	R2108	5B	R2215	3B	TP2133	5E
CR2140	5E	R2109	5B	R2217	2A	TP2135	4F
CR2141	5E	R2112	6B	R2219	3B	TP2154	2E
CR2142	5F	R2113	6B	R2220	3A	TP2159	6F
CR2145	5E	R2122	4D	R2221	3A	TP2180	3C
CR2146	5E	R2123	4E	R2226	4A	TP2199	3C
CR2156	4E	R2127	5D	R2227	4A	TP2209	2D
CR2157	4E	R2128	5D	R2229	2A	TP2211	2B
CR2162	2C	R2129	4D	R2231	5D	TP2232	7A
CR2163	2C	R2137	5E	R2235	6F	TP2226	4D
CR2166	2D	R2139	5F	R2236	6F	TP2250	1F
CR2167	2D	R2144	5E	R2237	6F	TP2251	4B
CR2170	2B	R2146	5E	R2238	6E	TP2296	3C
CR2171	2B	R2148	5E	R2241	4A	TP2299	4C
CR2174	2C	R2150	3B	R2251	3B	U2120	4B
CR2175	2C	R2151	3C	R2252	4C	U2126	4E
CR2182	2D	R2153	3C	R2253	4C	U2155	3E
CR2183	3D	R2155	3E	R2254	5D	U2159	2E
CR2198	3D	R2158	4E	R2251	5C	U2180	3D
CR2198	3D	R2161	2B	R2262	5D	U2185	6D
CR2226	4A	R2162	2C	R2265	6D	U2190	3B
J2092	5A	R2163	2C	R2266	6E	U2232	6E
J2132	5E	R2165	2B	R2268	5E	U2244	6B
J2138	4E	R2166	2D	R2273	6A	U2250	4B
J2138	4E	R2167	2D	R2274	6B	U2260	6E
J2296	3C	R2168	2B	R2275	6B	U2270	6B
J2298	3D	R2170	2B	R2276	6D	U2272	6C
		R2171	2B	R2277	6D	U2274	6C
L2283	5D	R2173	2B	R2278	5D	U2276	6D
		R2174	2C	R2279	5C	U2278	6D
P2118	2A	R2175	2C	R2280	5D	U2284	5C
P2167	2F	R2177	3B	R2281	5C	VR2262	6E
P2250	2F	R2178	3B	R2282	5D	VR2263	6E
P2165	2B	R2179	3C	R2283	4D	VR2264	6E
				R2284	5C		

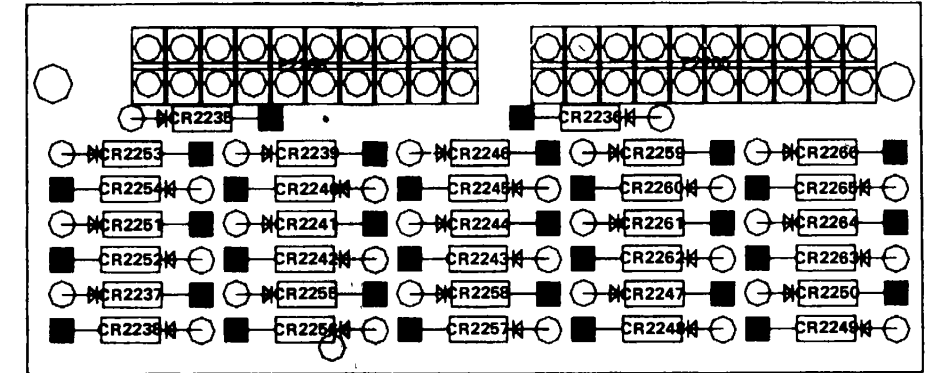
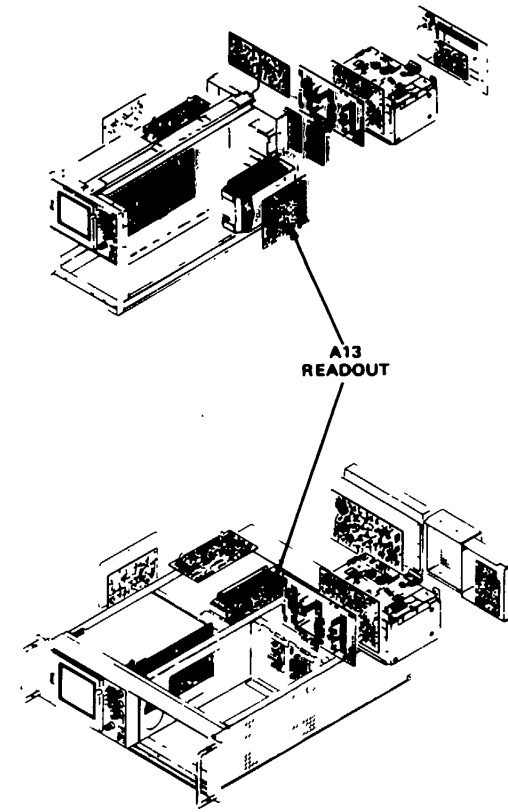

Figure 8-15A. A18-Protection circuit board (SN B14000-up).

VOLTAGES AND WAVEFORMS

The voltages and waveforms shown on this diagram were obtained using the recommended test equipment and test set-ups listed below

ITEM	RECOMMENDED TEST EQUIPMENT	
	SPECIFICATIONS	RECOMMENDED TYPE
Oscilloscope	Frequency response	DC to 65 MHz
	Deflection factor	5 mV to 5 V/Div
	Input impedance	10 MΩ, 20 pF
	Sweep rate	500 ns
Probe	Fast rise 10X attenuation probe compatible with the vertical amplifier of the test oscilloscope	Tektronix P6053B, or equivalent.
	Voltmeter (Non-Loading Digital Multimeter)	10 MΩ Range 0 to 500 V

VOLTAGE MEASUREMENTS

Voltage measurements on this diagram were made under the following conditions:
 Set front panel controls (knob type) to mid-range
 Set VERT MODE for CHOP.
 Set TRIG SOURCE for VERT MODE
 Set for NON STORE condition
 No plug-in units are installed.
 Voltmeter common is connected to chassis ground

WAVEFORMS

Waveforms shown on this diagram were obtained under the following conditions:
 7623A OSCILLOSCOPE UNDER TEST. Front panel controls are set the same as for voltage measurements. No plug-ins are installed.

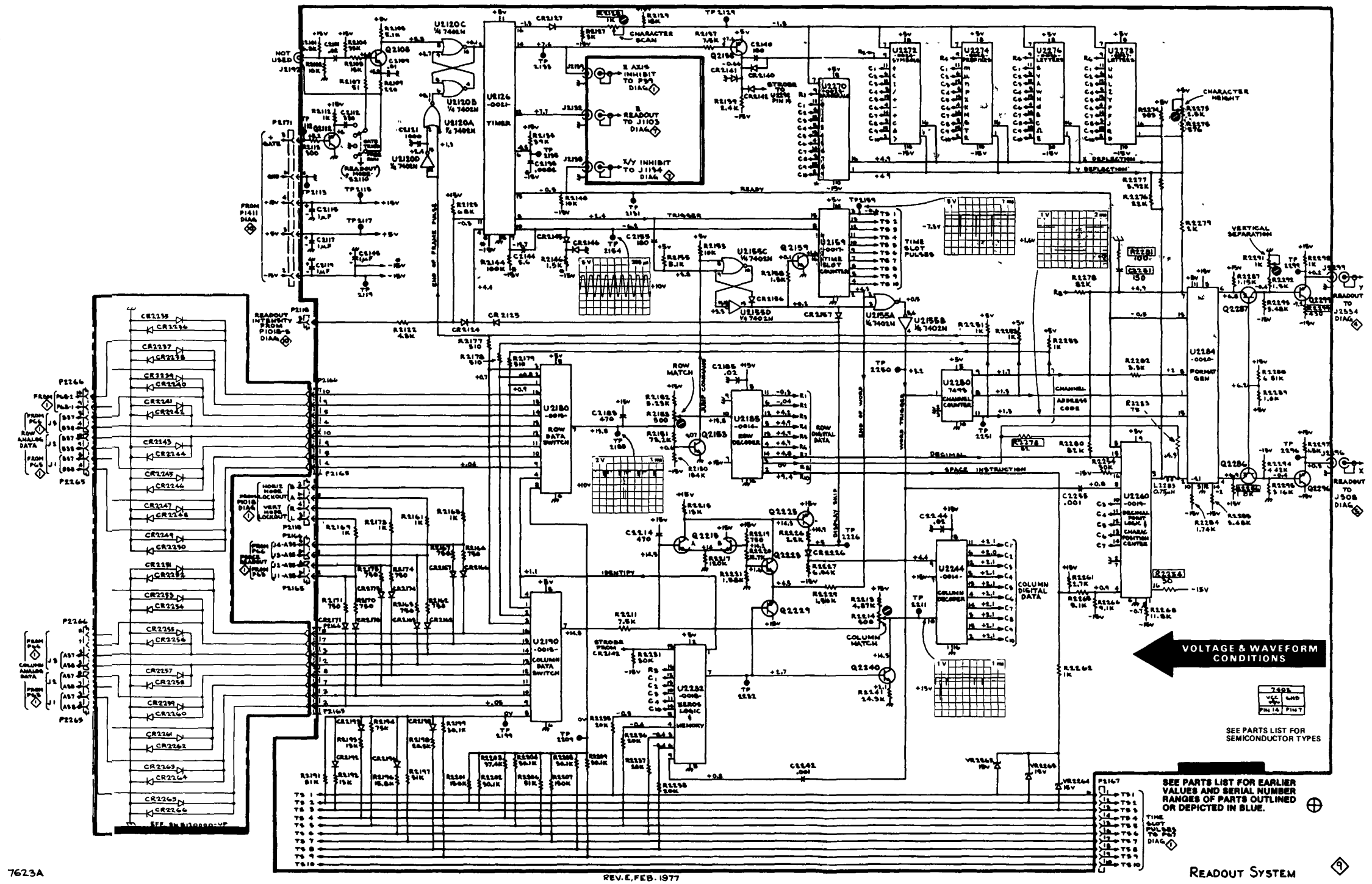

7623A

REV. E, FEB. 1977

READOUT SYSTEM

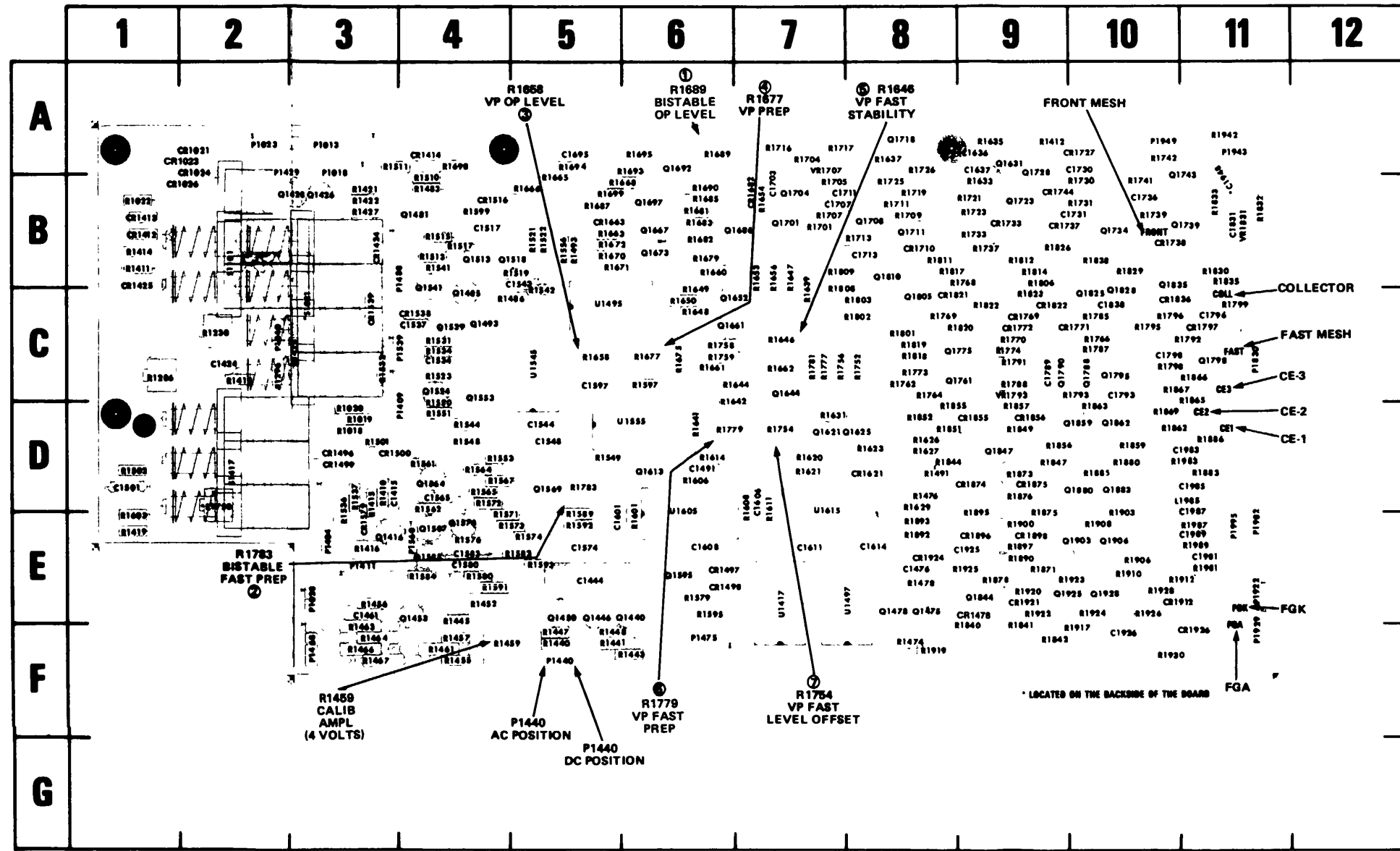
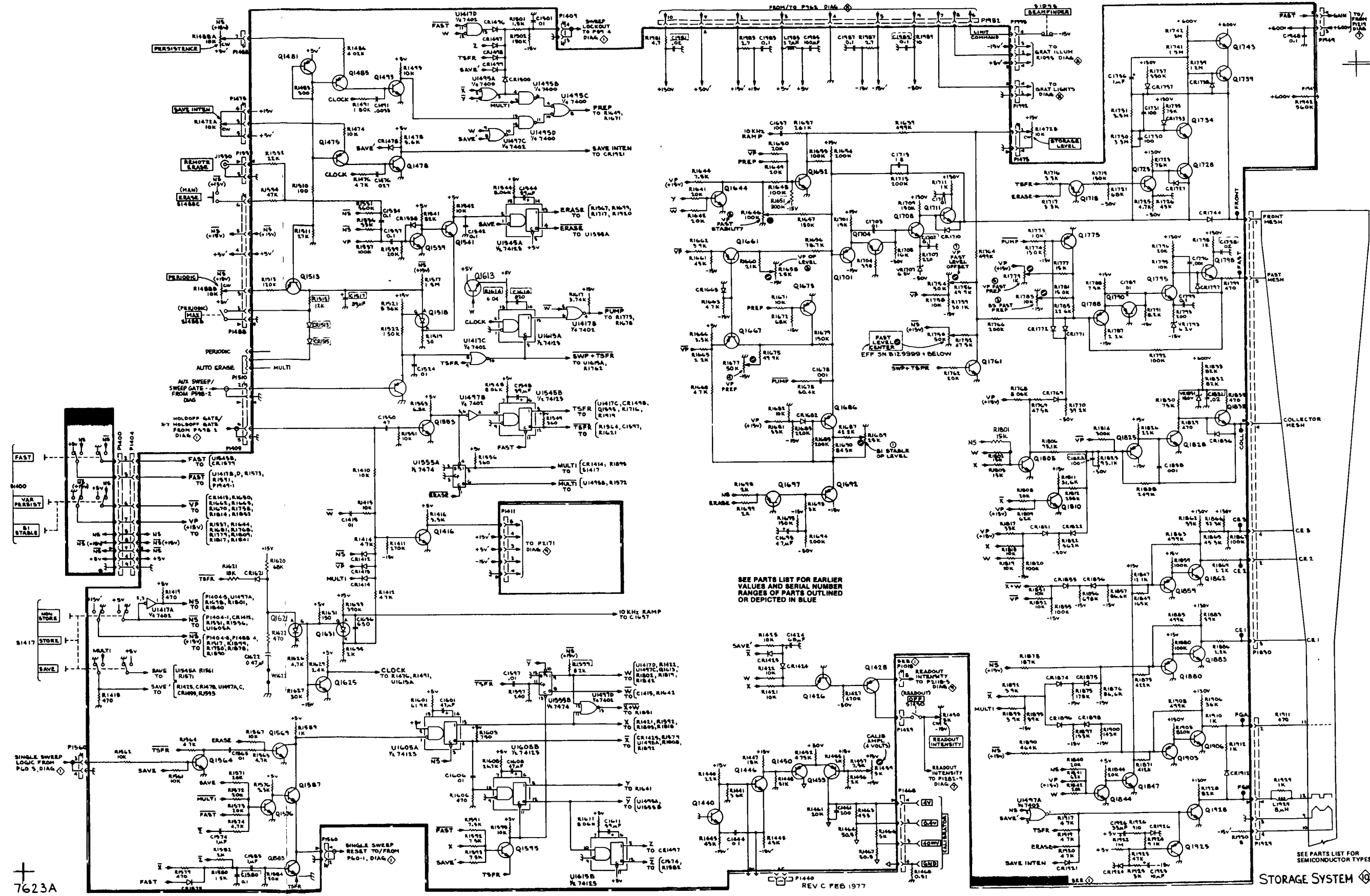

Figure 8-16B. A14-Storage board, SN B129999-below.

COMPONENT
LOCATION INDEX

CKT NO	GRID LOC	CKT NO	GRID LOC	CKT NO	GRID LOC	CKT NO	GRID LOC	CKT NO	GRID LOC	CKT NO	GRID LOC	CKT NO	GRID LOC
C1415	3D	CR1800	3D	Q1518	4B	R1416	3E	R1576	4E	R1704	7A	R1832	11B
C1424	2C	CR1816	4B	Q1524	4C	R1414	1B	R1579	6E	R1705	7B	R1833	11B
C1444	5E	CR1838	4C	Q1539	4C	R1415	3D	R1580	4E	R1707	7B	R1835	11B
C1481	3E	CR1839	3C	Q1541	4C	R1418	2C	R1582	5E	R1708	8B	R1836	10B
C1476	8E	CR1879	3E	Q1553	4C	R1419	1E	R1584	4E	R1711	8B	R1840	9F
C1491	6D	CR1821	8D	Q1564	4D	R1421	3B	R1589	5E	R1713	8B	R1841	9F
C1501	1D	CR1883	5B	Q1580	5D	R1422	3B	R1591	4E	R1716	7A	R1842	9F
C1517	4B	CR1882	7B	Q1578	4E	R1425	2C	R1592	5E	R1717	7A	R1844	8D
C1534	4C	CR1710	8B	Q1586	4E	R1427	3B	R1593	5E	R1719	8B	R1847	9D
C1537	4C	CR1727	10A	Q1587	4E	R1440	5F	R1595	6E	R1721	9B	R1848	9D
C1542	5B	CR1733	9B	Q1596	6E	R1441	5F	R1597	6C	R1723	9B	R1851	8D
C1544	5D	CR1737	9B	Q1613	6D	R1443	6F	R1598	4B	R1725	8B	R1852	8D
C1548	5D	CR1738	10B	Q1621	7D	R1445	4E	R1601	6E	R1730	10B		
C1565	4D	CR1744	9B	Q1625	8D	R1447	5F	R1603	1E	R1736	8A	R1855	8D
C1574	5E	CR1769	9C	Q1631	9A	R1448	5F	R1606	6D	R1731	10B	R1856	9D
C1580	4E	CR1771	10C	Q1644	7C	R1453	4E	R1608	7D	R1733	9B	R1857	9D
C1583	4E	CR1772	9C	Q1652	6C	R1455	4F	R1611	7D	R1737	9B	R1859	10D
C1597	5C	CR1797	11C	Q1661	6C	R1456	3E	R1614	6D	R1739	10B	R1862	10D
C1601	5E	CR1821	8C	Q1667	6B	R1457	4F	R1620	7D	R1741	10B	R1863	10D
C1606	7D	CR1822	9C	Q1673	6B	R1459	4F	R1621	7D	R1742	10A	R1865	11D
C1608	6E	CR1836	10C	Q1686	7B	R1461	4F	R1623	8D	R1742	10A	R1866	11C
C1611	7E	CR1856	9D	Q1682	6A	R1463	3F	R1626	8D	R1750	2D	R1867	10C
C1614	8E	CR1856	9D	Q1687	6B	R1464	3F	R1627	8D	R1752	8C	R1867	10C
		CR1874	9D	Q1701	7B	R1466	3F	R1629	8D	R1754	7D	R1869	10D
C1636	9A	CR1875	9D	Q1704	7B	R1467	3F	R1631	7D	R1756	7C	R1871	9E
C1637	9A	CR1898	9E	Q1708	8B	R1474	8F	R1633	9B	R1756	6C	R1873	9D
C1696	5A	CR1896	9E	Q1711	8B	R1476	8D	R1635	9A	R1762	9C	R1876	9D
C1703	7B	CR1912	10E	Q1718	8A	R1478	8E	R1637	8A	R1762	9C	R1878	9E
C1707	7B	CR1921	9E	Q1728	9B	R1483	4B	R1639	7C	R1764	9C	R1880	10D
C1711	7B	CR1926	11F	Q1723	9B	R1486	4C	R1639	7C	R1766	10C	R1880	10D
C1713	8B	CR1924	8E	Q1734	10B	R1491	8D	R1641	6D	R1768	9B	R1883	11D
C1730	10A	L1985	11D	Q1739	11B	R1493	5B	R1642	6D	R1768	9B	R1885	10D
C1731	10B	P1013	3A	Q1743	11B	R1493	5B	R1644	6C	R1770	9C	R1886	11D
C1736	10B	P1018	3A	Q1761	8C	R1501	3D	R1646	7C	R1773	9C	R1890	9E
C1789	9C	P1023	2A	Q1775	8C	R1502	1D	R1647	7B	R1774	9C	R1892	8E
C1793	10C	P1409	3D	Q1788	10C	R1510	4B	R1648	6C	R1777	7C	R1893	8E
C1796	11C	P1028	3E	Q1790	9C	R1511	3A	R1649	6C	R1779	6D	R1895	9E
C1798	10C	P1404	3E	Q1795	10C	R1513	4B	R1650	6C	R1781	7C	R1897	9E
C1831	11B	P1411	3E	Q1798	11C	R1515	4B	R1653	7B	R1783	5D	R1900	9E
C1838	10C	P1429	2A	Q1805	8C	R1517	4B	R1654	7B	R1785	10C	R1903	10E
C1925	9E	P1440	5F	Q1810	8B	R1521	5B	R1656	7B	R1787	10C	R1908	11E
C1926	10F	P1468	3F	Q1825	10C	R1522	5B	R1658	5C	R1788	9C	R1906	10E
C1935	11D	P1475	6F	Q1828	10C	R1523	4C	R1660	6B	R1791	9C	R1910	10E
C1948	11B	P1488	3B	Q1835	10C	R1519	5B	R1661	6C	R1782	11C	R1912	10E
C1981	11E	P1539	3C	Q1844	9E	R1531	4C	R1662	7C	R1783	10C	R1917	10F
C1983	11D	P1580	4E	Q1847	9D	R1532	3C	R1663	5B	R1785	10C	R1919	8F
C1987	11E	P1830	11C	Q1849	9E	R1534	4C	R1665	5B	R1786	10C	R1920	9E
C1989	11E	P1922	11E	Q1859	10D	R1536	3E	R1666	5B	R1786	10C	R1922	9E
		P1929	11F	Q1862	10D	R1537	3D	R1668	5B	R1790	11C	R1923	9E
CEC	11C	P1943	11A	Q1880	10D	R1541	4B	R1670	5B	R1801	8C	R1924	10E
CE1	11D	P1982	11E	Q1883	10D	R1542	5C	R1671	5B	R1802	8C	R1925	9E
CE2	11D	P1995	11E	Q1903	10E	R1544	4D	R1672	5B	R1803	8C	R1926	10E
				Q1906	10E	R1548	4D	R1675	6C	R1806	9B	R1928	10E
CR1021	2A			Q1925	9E	R1549	5D	R1677	6C	R1808	7C	R1930	10F
CR1023	2A	Q1416	3E	Q1928	10E	R1550	4D	R1679	6B	R1809	7B	R1942	11A
CR1024	2A	Q1426	3B			R1551	4D	R1681	6B	R1811	8B	R1949	10A
CR1026	1B	Q1428	2B			R1553	4D	R1682	6B	R1812	8B	R1981	11E
CR1412	1B	Q1440	6E			R1556	5B	R1683	6B	R1814	9B	R1983	11D
CR1413	1B	Q1446	5E			R1561	4D	R1685	6B	R1818	8C	R1987	11E
CR1414	4A	Q1450	5E			R1562	4D	R1687	5B	R1817	8B	R1989	11E
CR1424	3B	Q1453	4E			R1564	4D	R1690	6B	R1819	8C		
CR1425	1B	Q1475	8E			R1564	4D	R1683	6A	R1820	8C	S1021	3C
CR1478	9E	Q1478	8E			R1240	2C	R1567	4D	R1822	9C	S1101	2B
CR1496	3D	Q1481	4B			R1286	1C	R1568	4D	R1824	9C	S1417	2D
CR1497	6E	Q1485	4C			R1296	2C	R1571	4E	R1826	9B		
CR1498	6E	Q1493	4C			R1410	3D	R1572	4D	R1829	10B	U1417	7E
CR1499	3D	Q1513	4B			R1411	1B	R1573	4E	R1699	5B	U1495	5C
						R1412	9A	R1574	5E	R1701	7B		



7623A

REV C FEB 1977

STORAGE SYSTEM

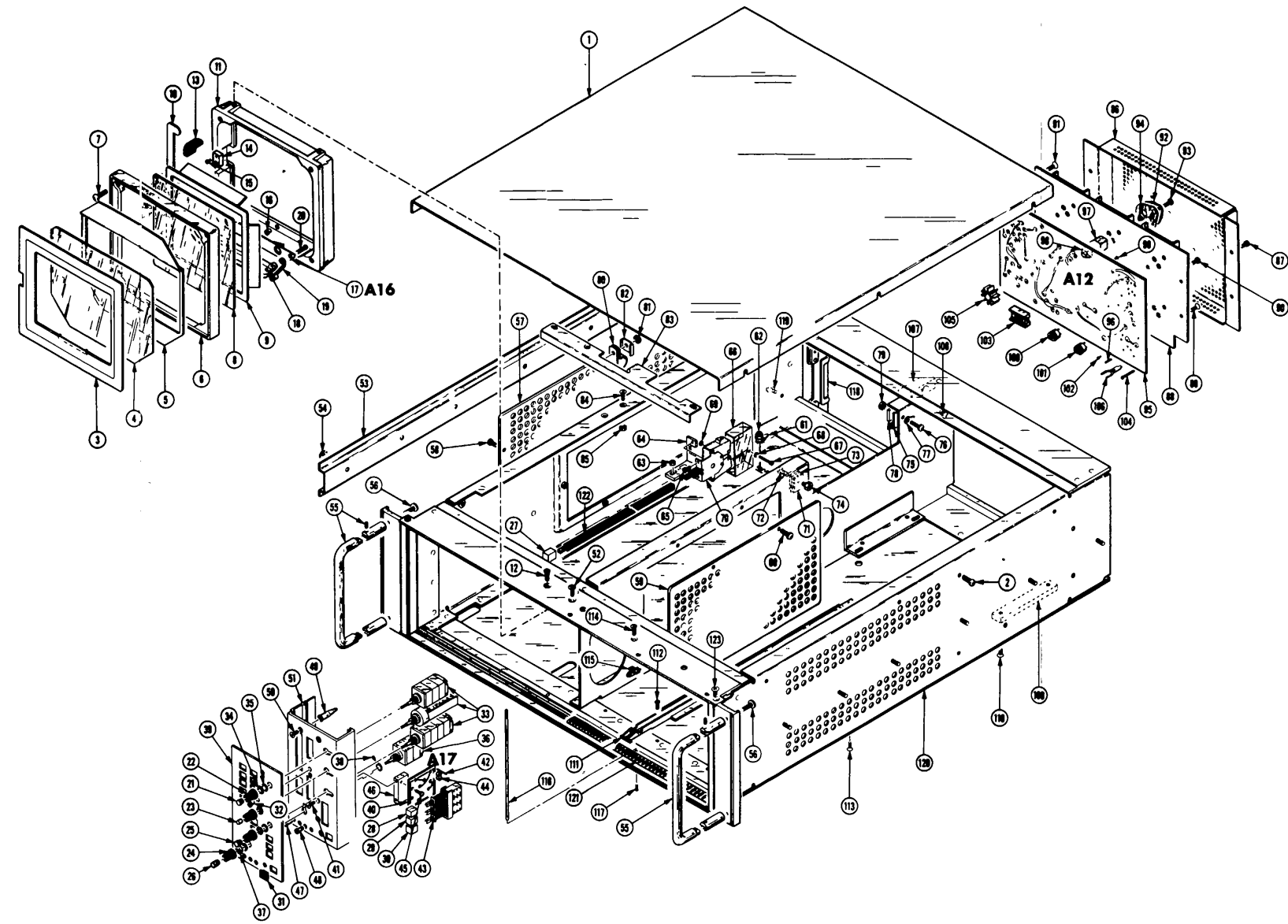

REV. D MAY 1976

7623A/R7623A STORAGE OSCILLOSCOPE

